

SIZE	2.2ft x 0.4ft x 0.4ft	PIECES	250
DESIGNER	Derek Sharman	MADE IN	U.S.A.

# BACKHOE

⚠ WARNING: Small parts. Age 14+. Not a toy. Handle responsibly. U.S. Patent 9,086,087.



Wrong  
Connecting/Disconnecting Two Directions

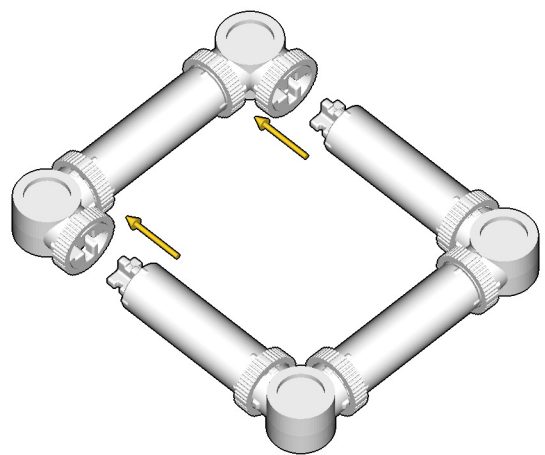

Right  
Connecting/Disconnecting One Direction

1



New pieces are drawn blue. Old pieces are drawn white.  
See back for piece names.

2

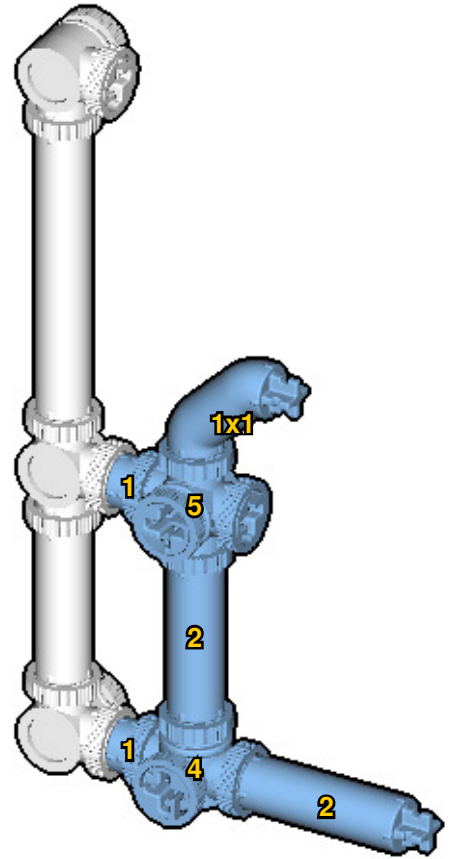

Connect new pieces together before connecting to old pieces.

3

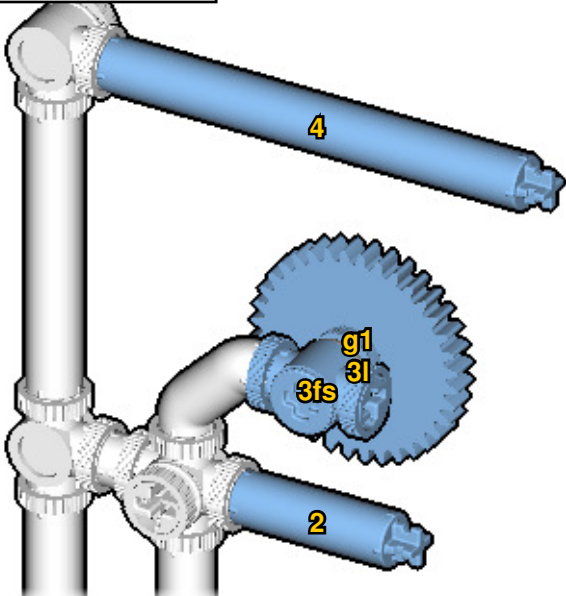
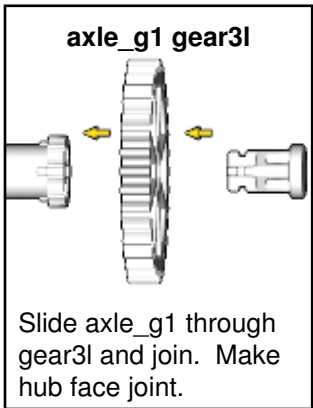

4

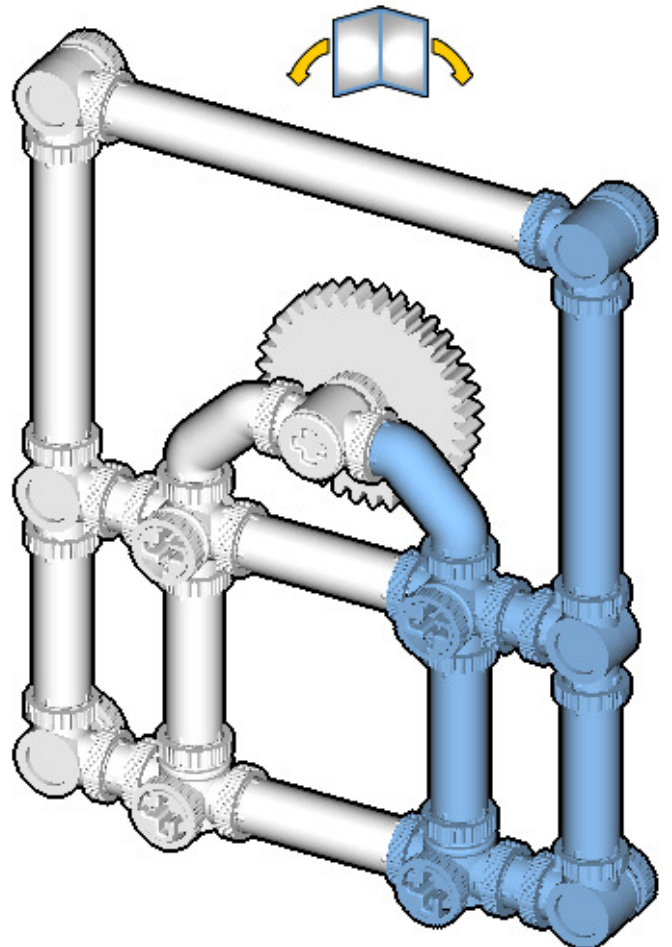

 : Copy new pieces from old pieces.

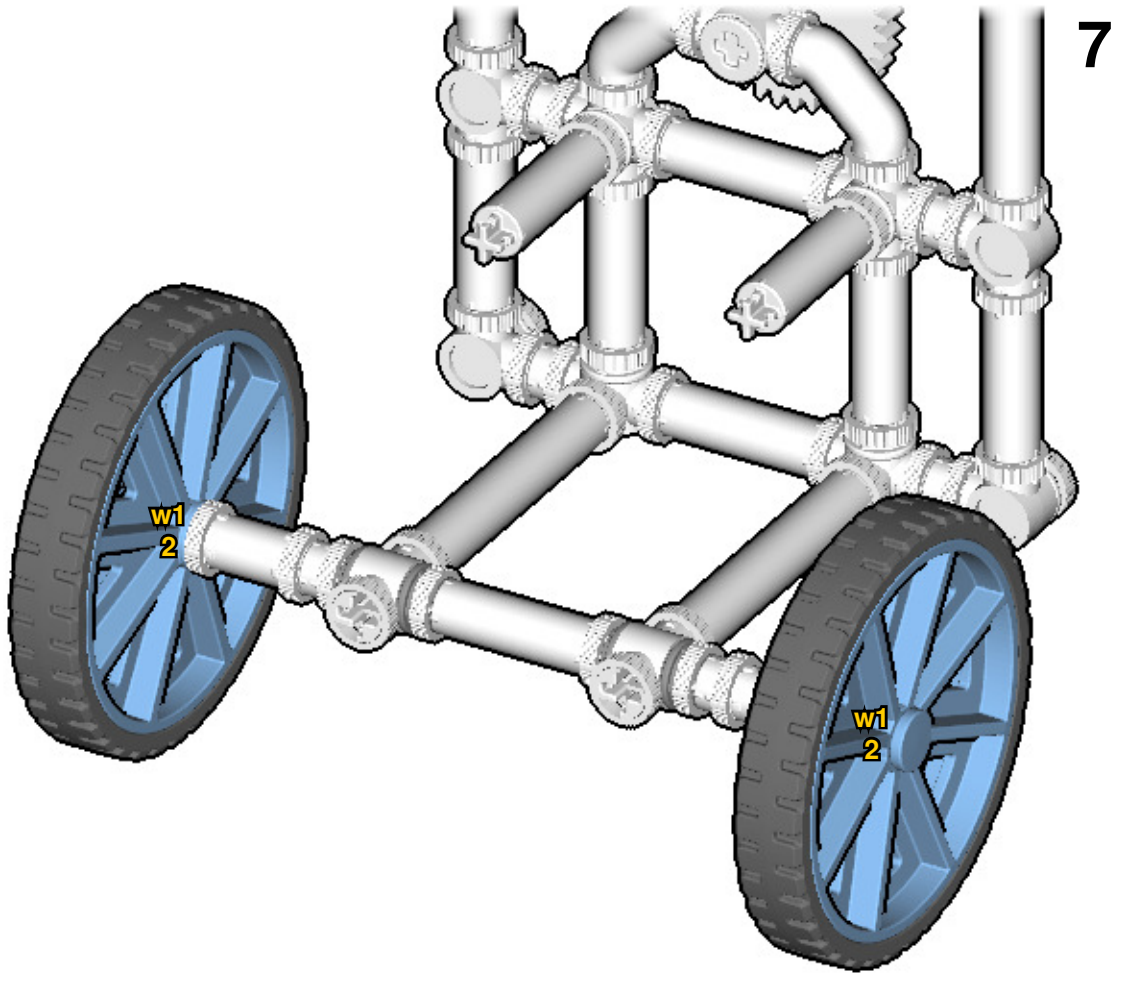
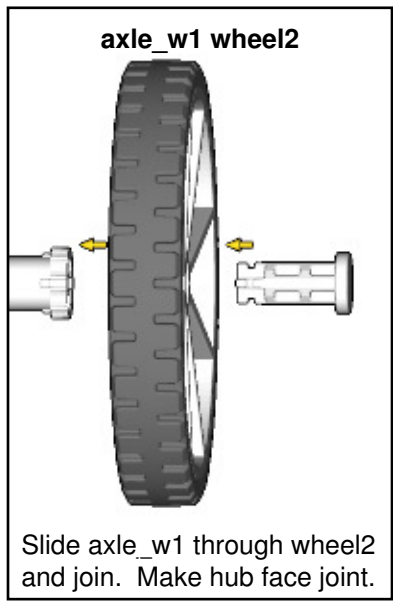
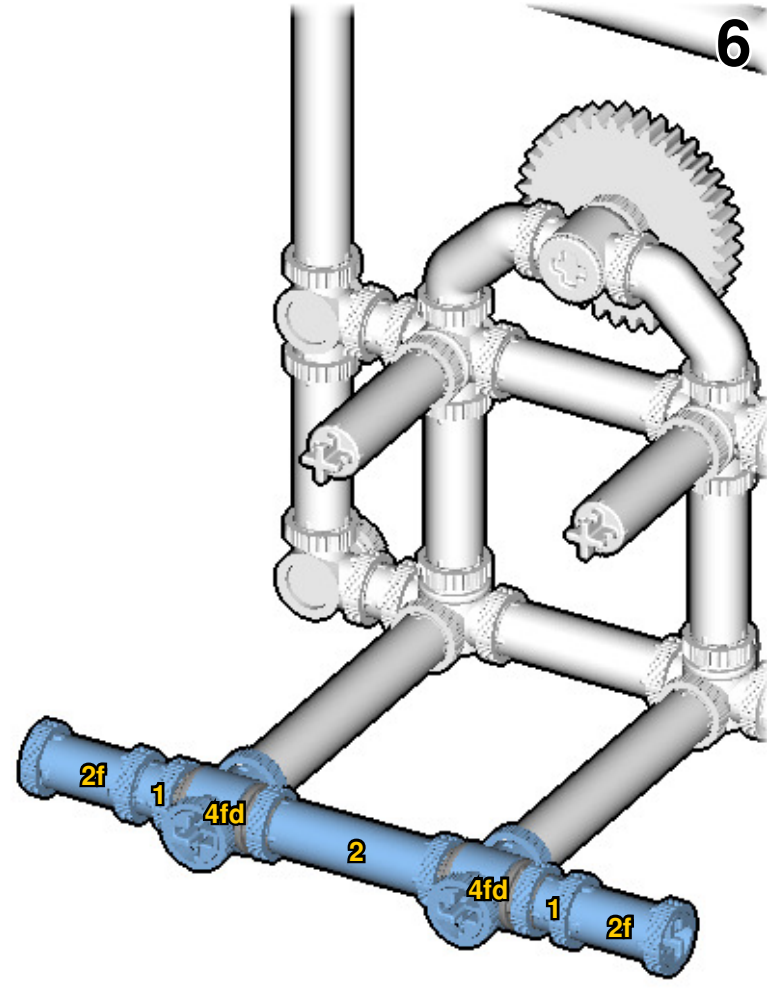
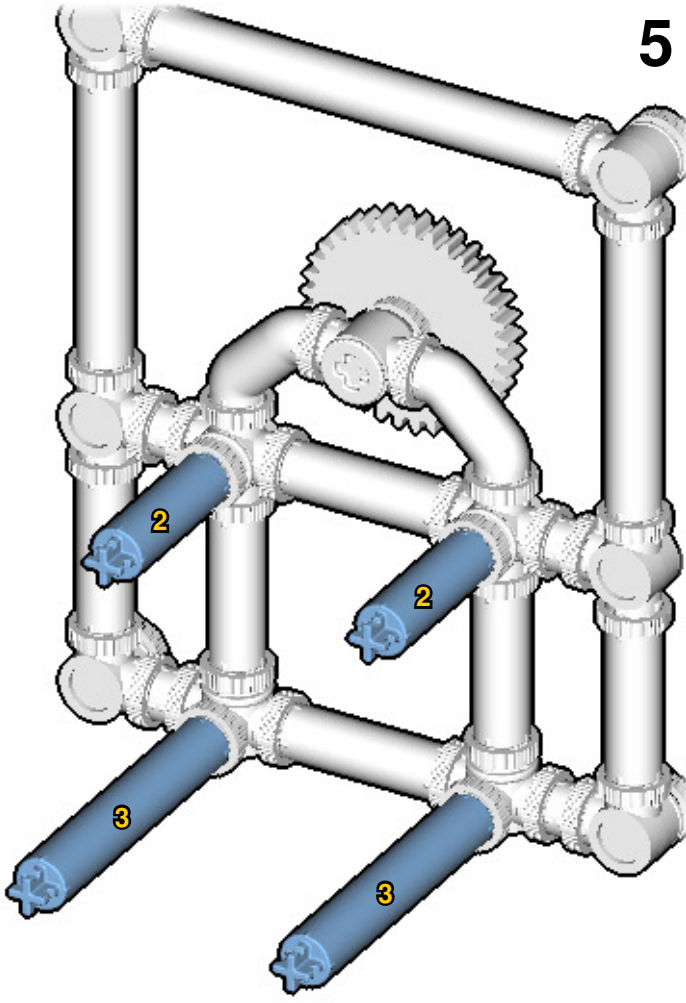

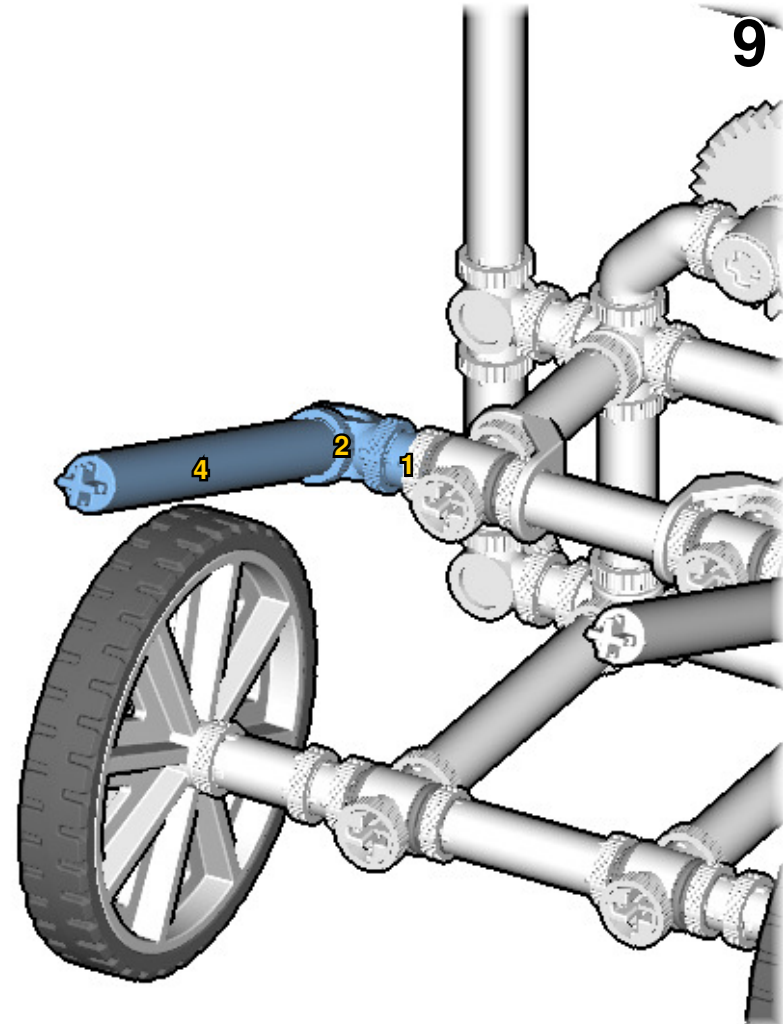
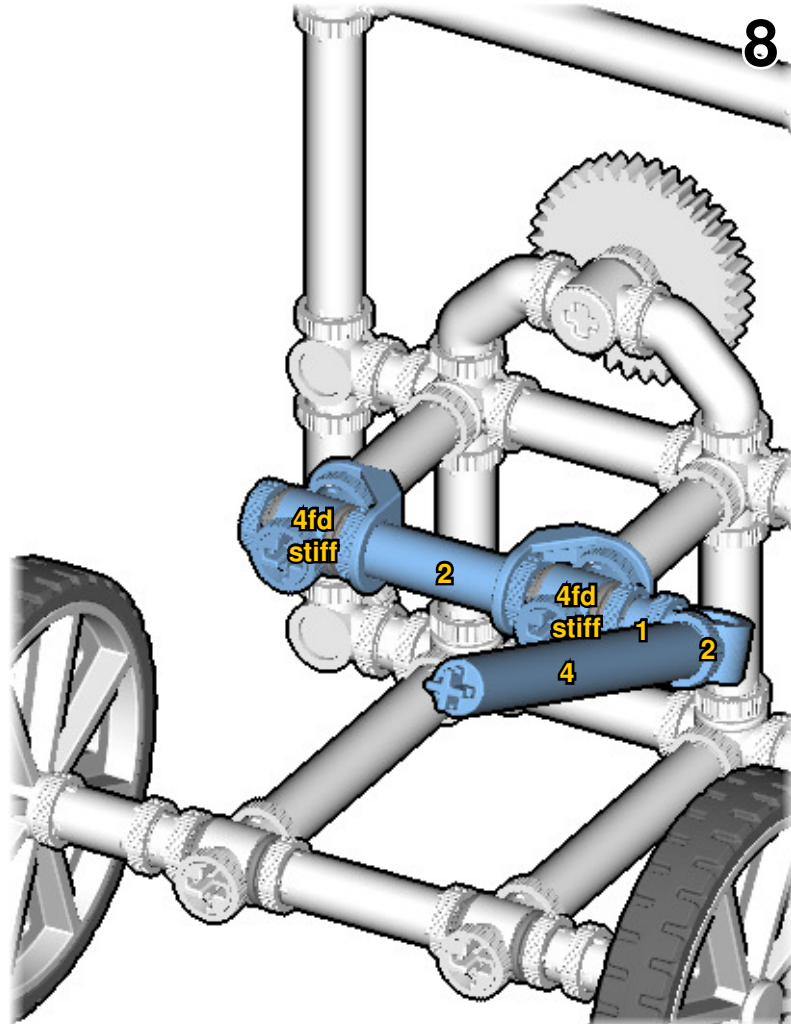

Submodel begins → **10**

**11**

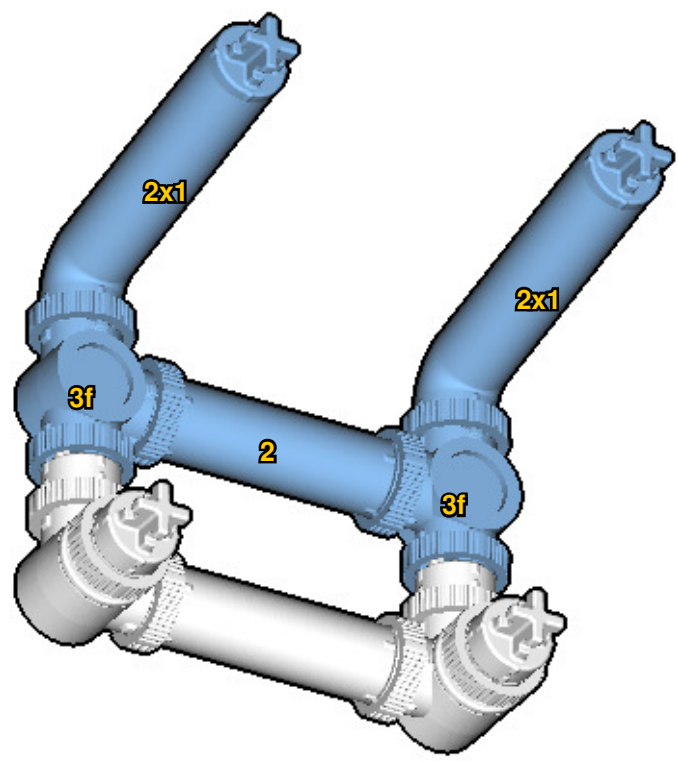
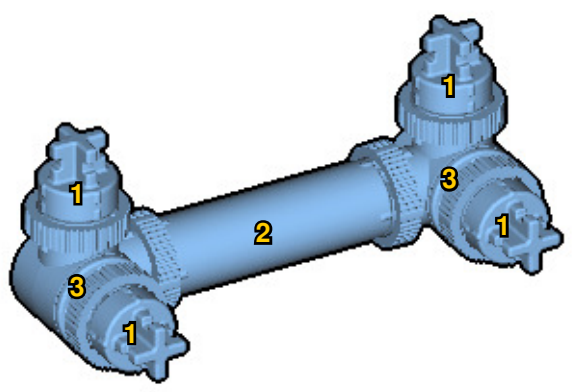

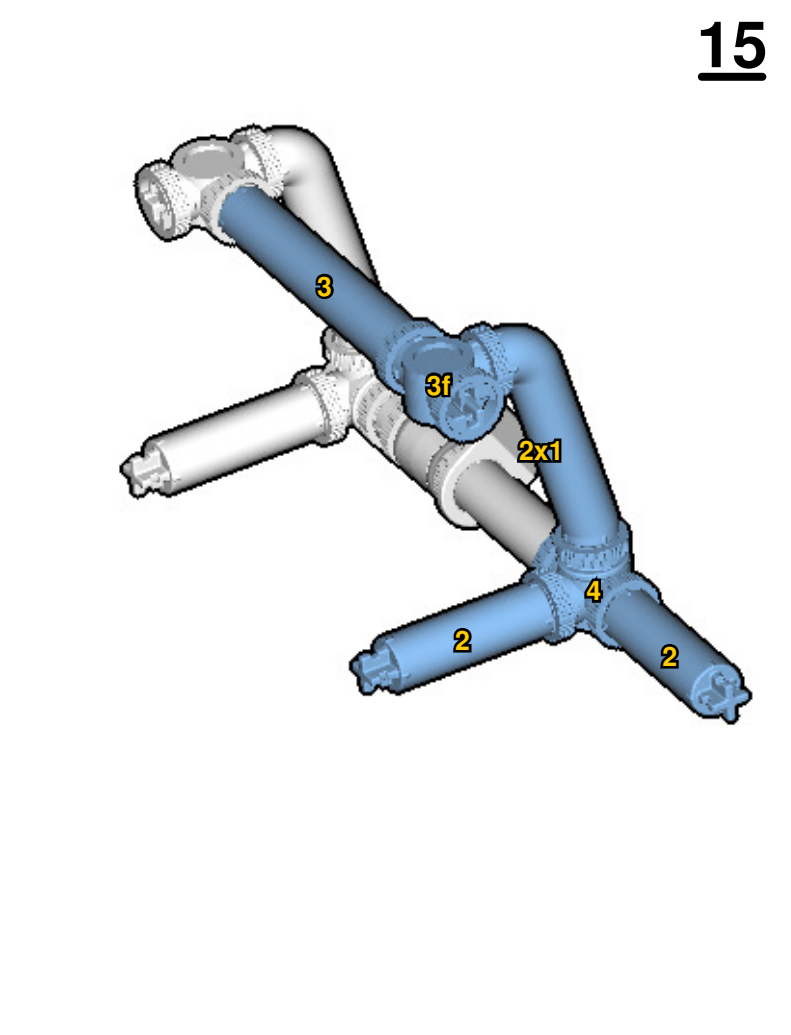
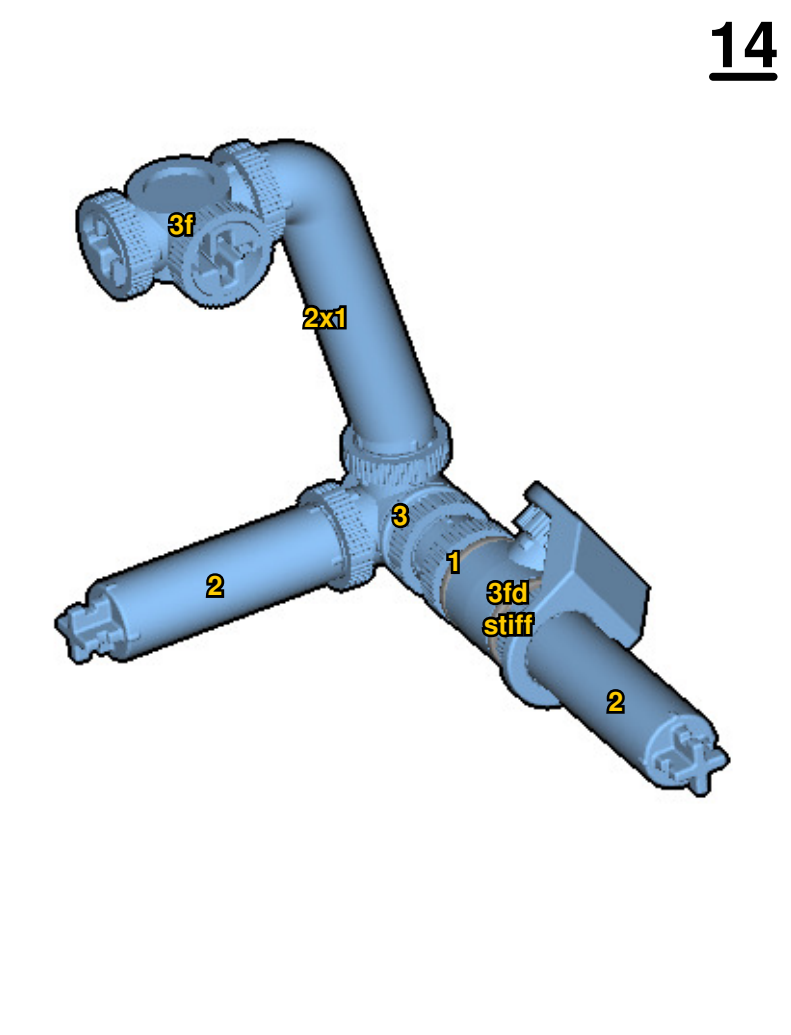
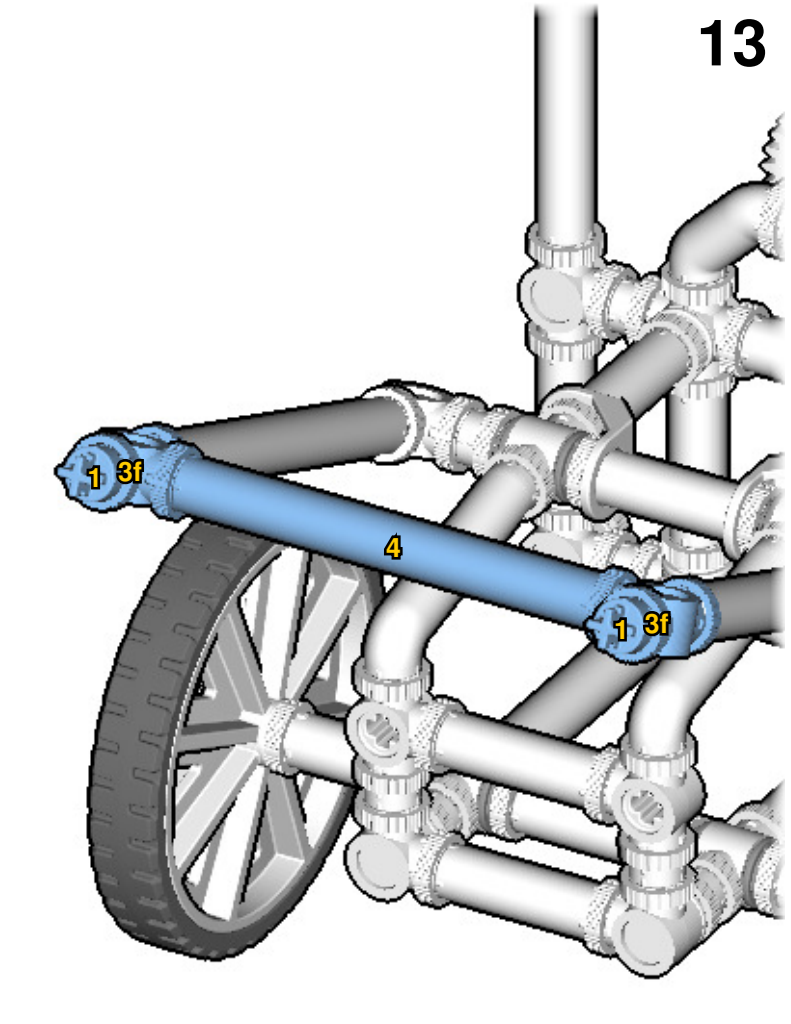
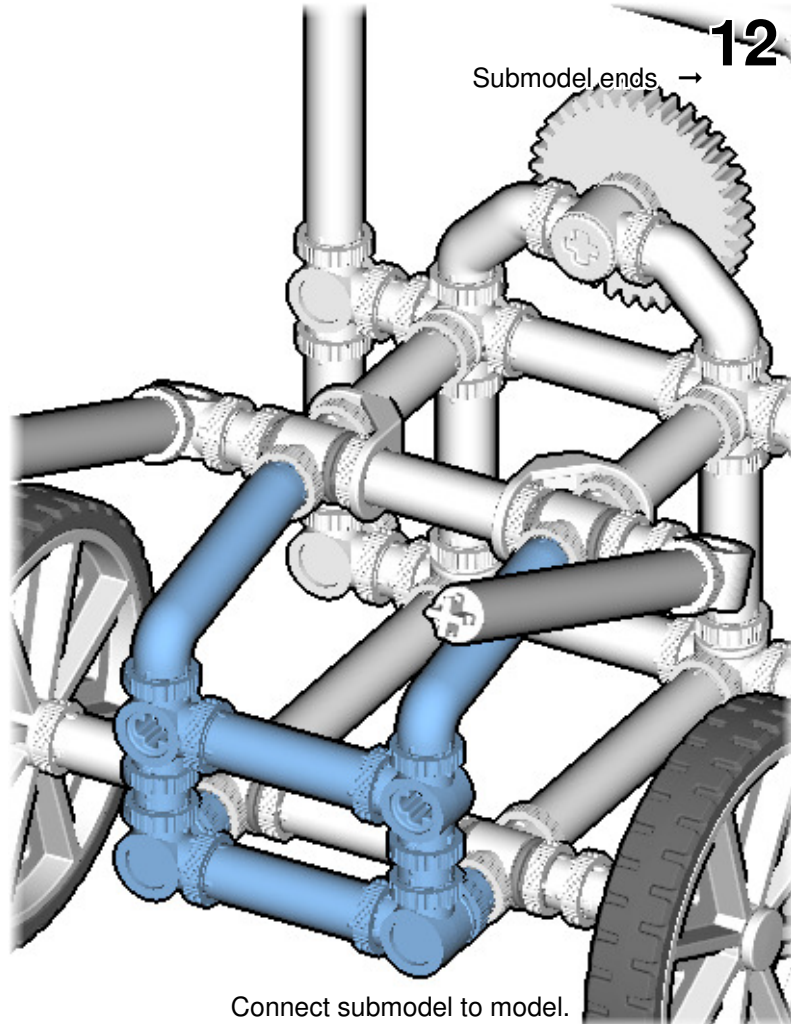

16

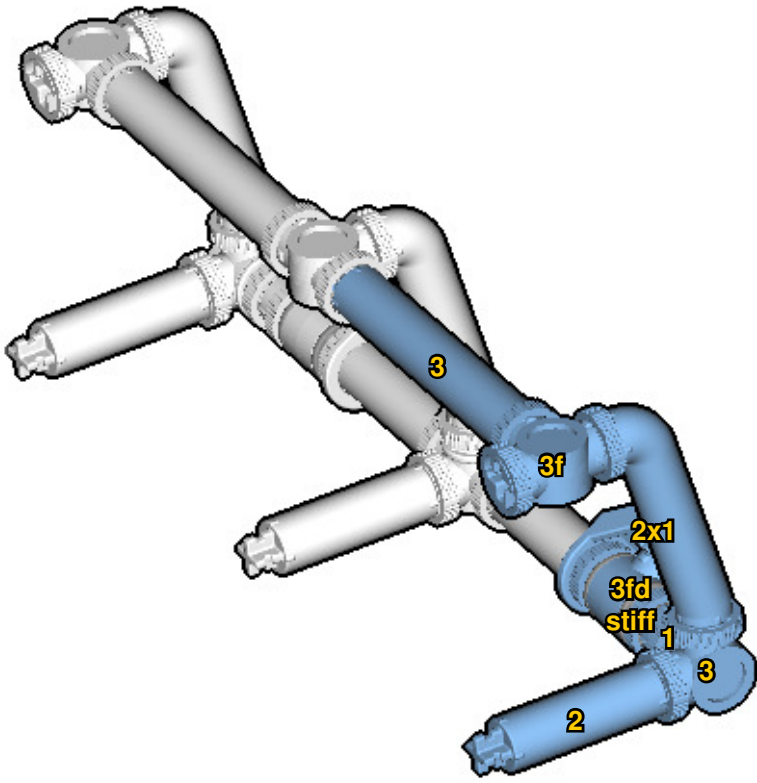

17

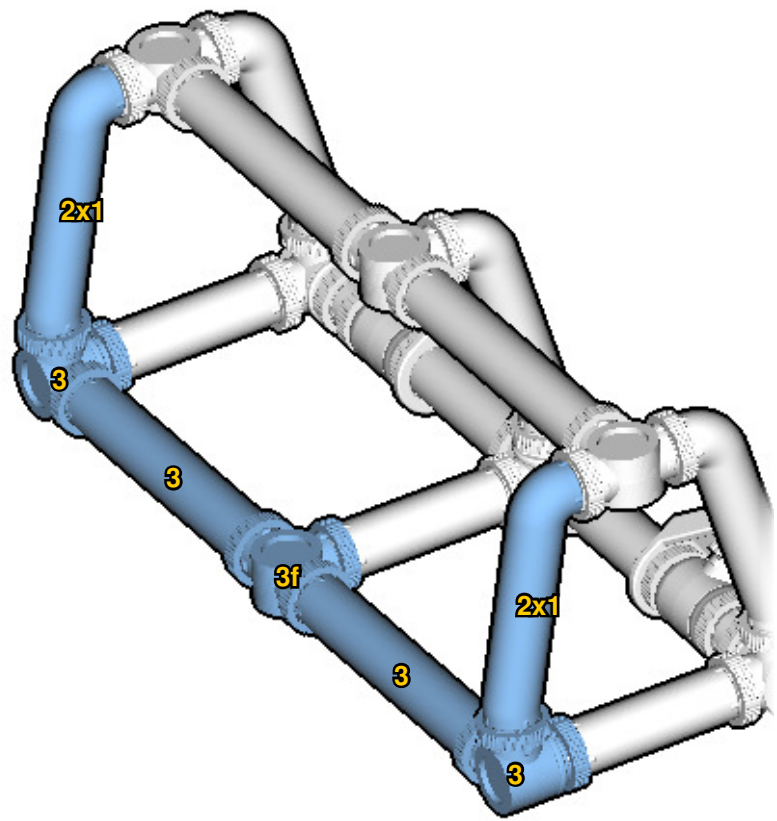

18

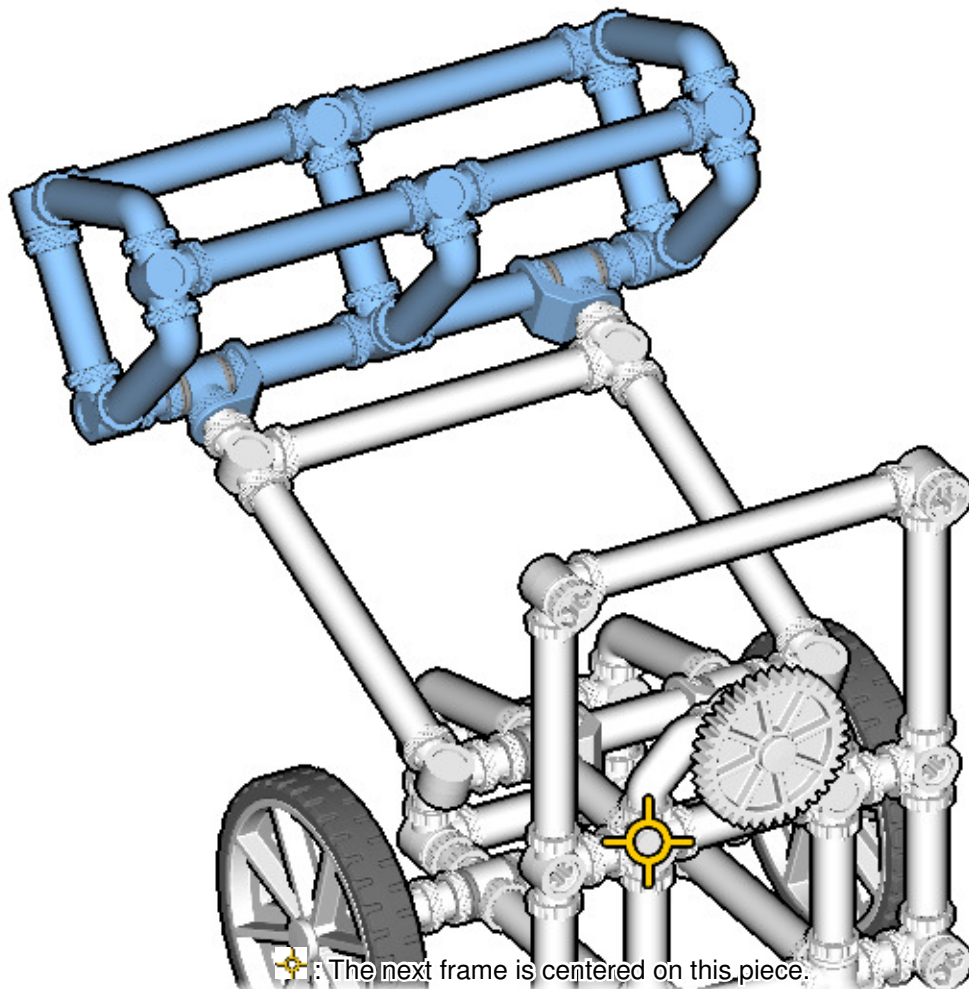

 : The next frame is centered on this piece.

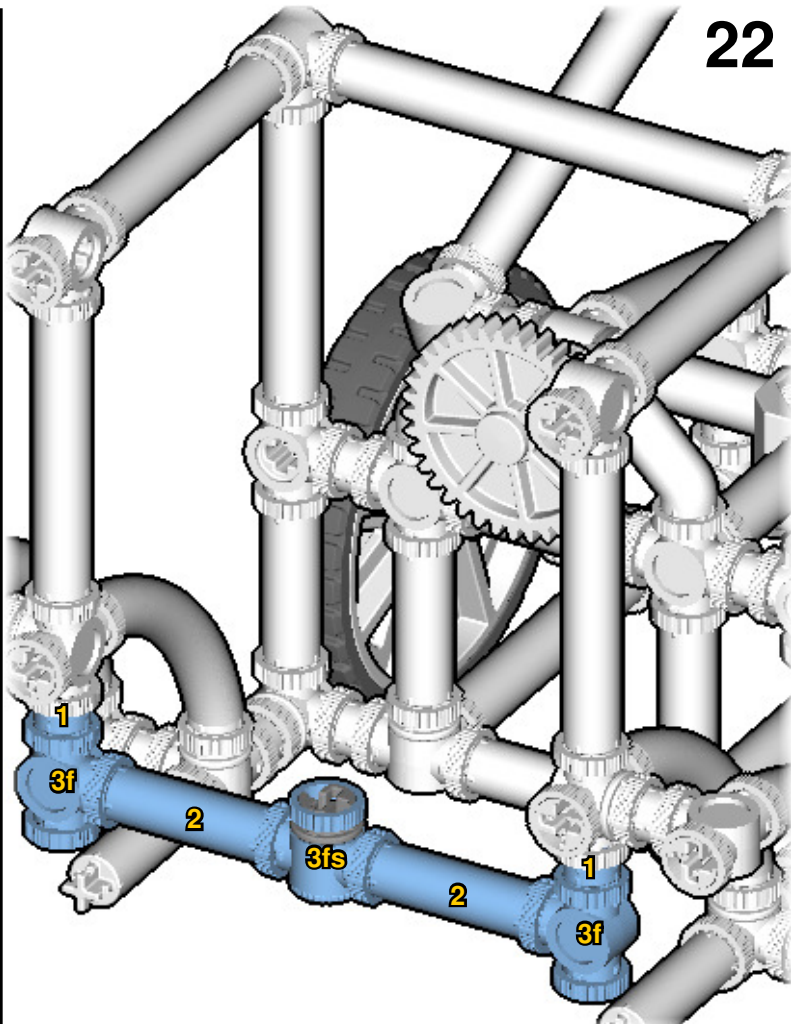
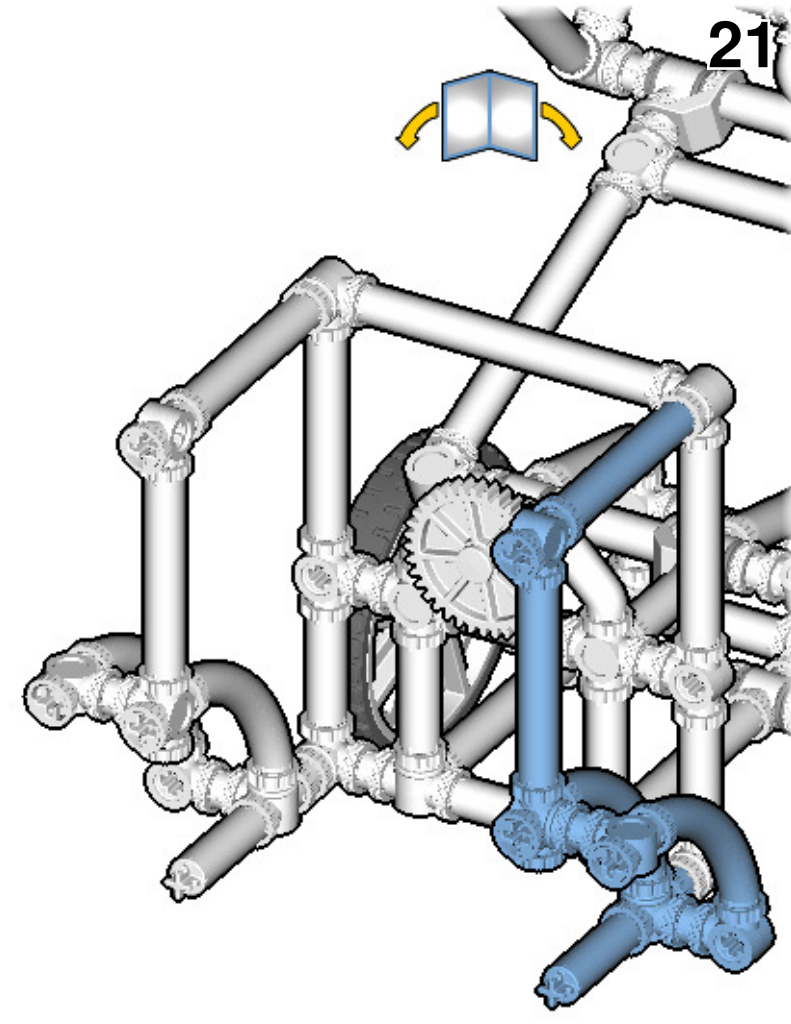
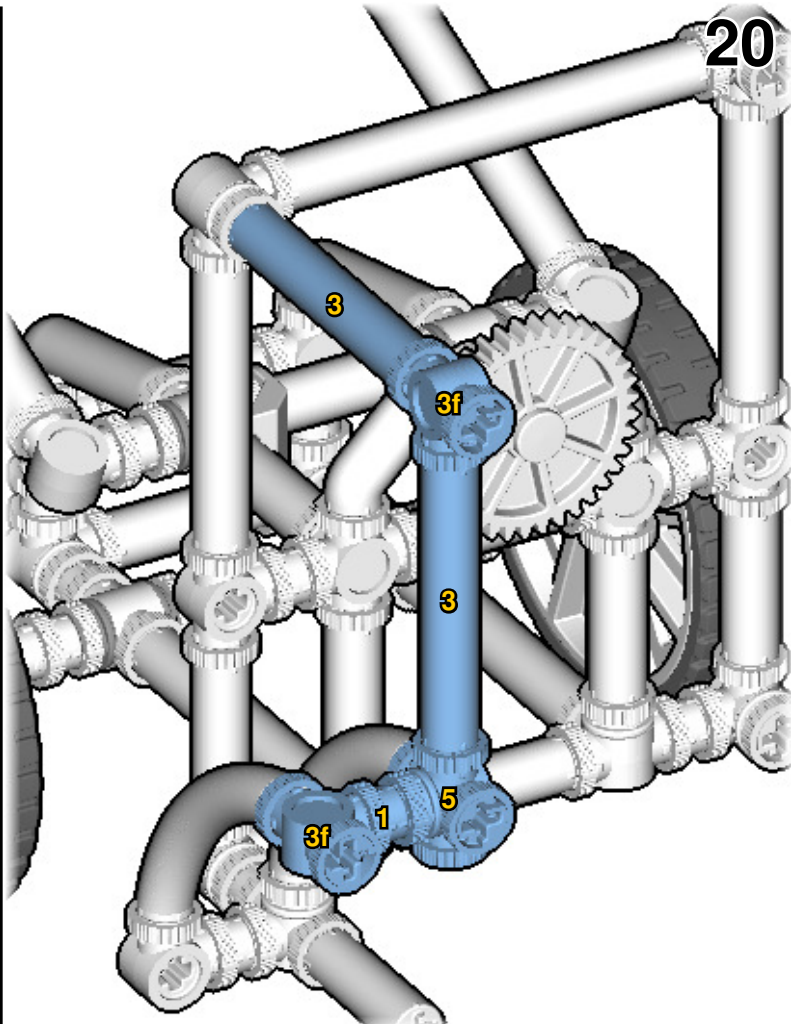
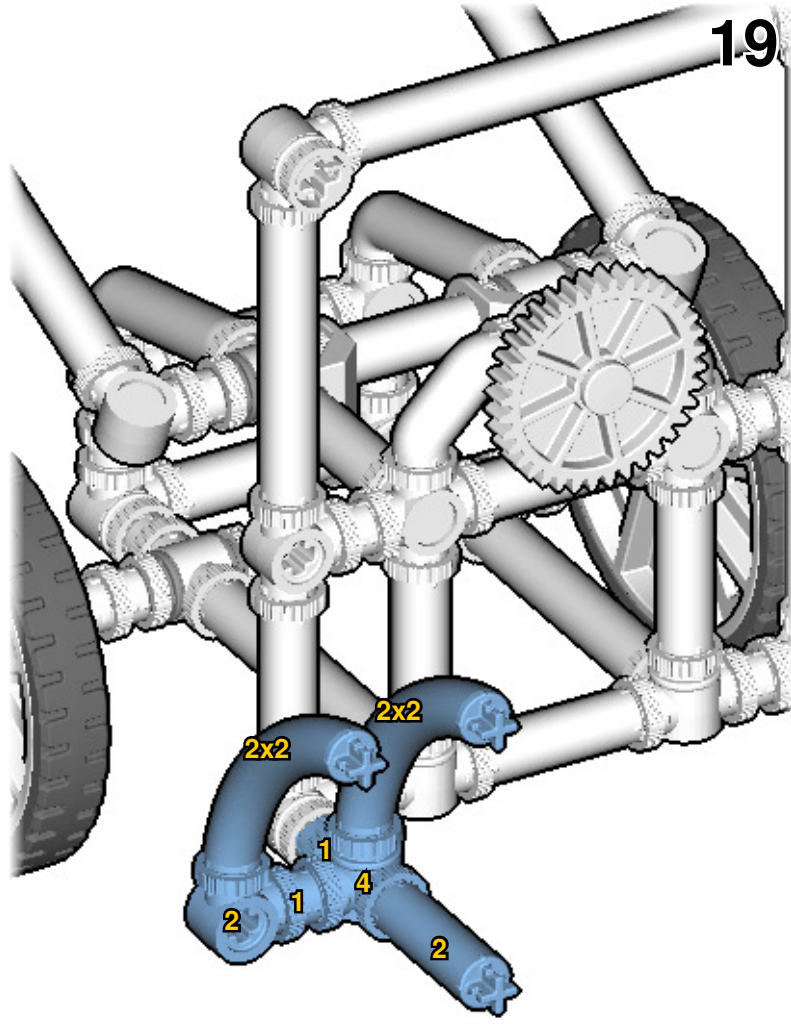



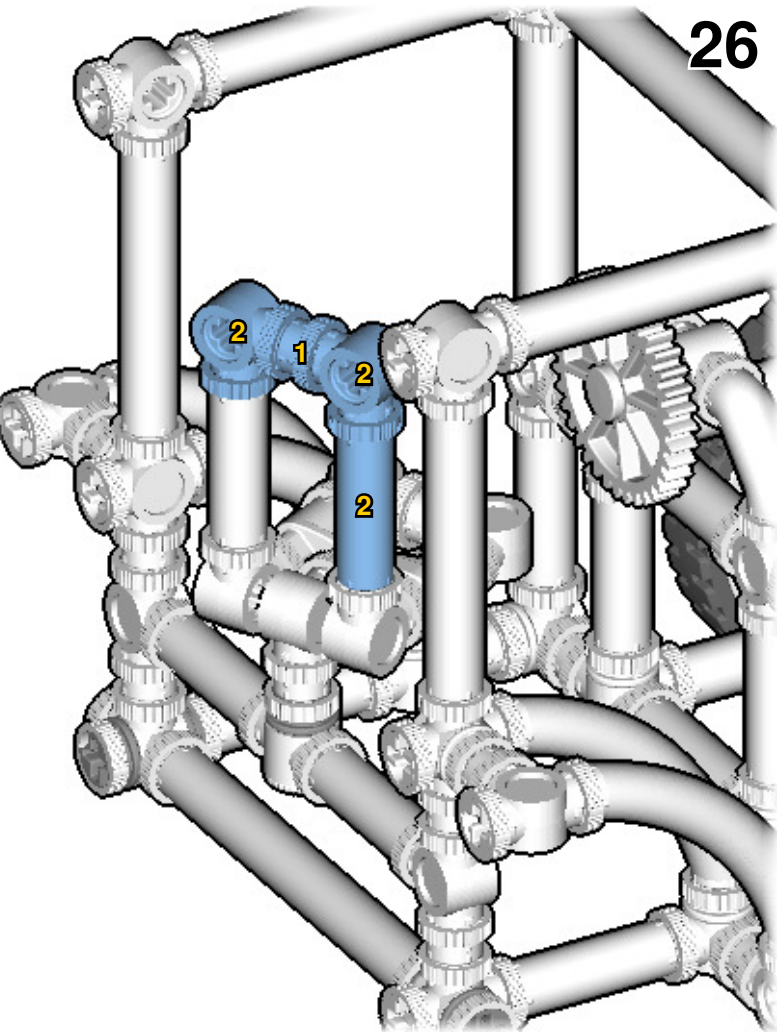
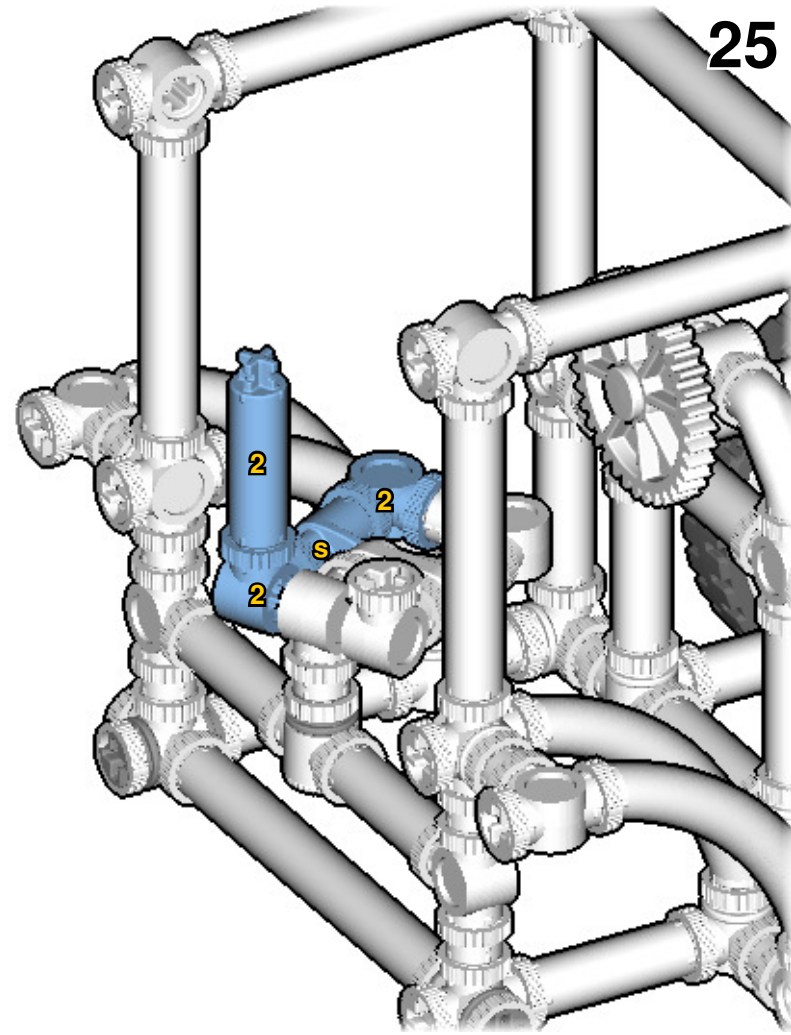
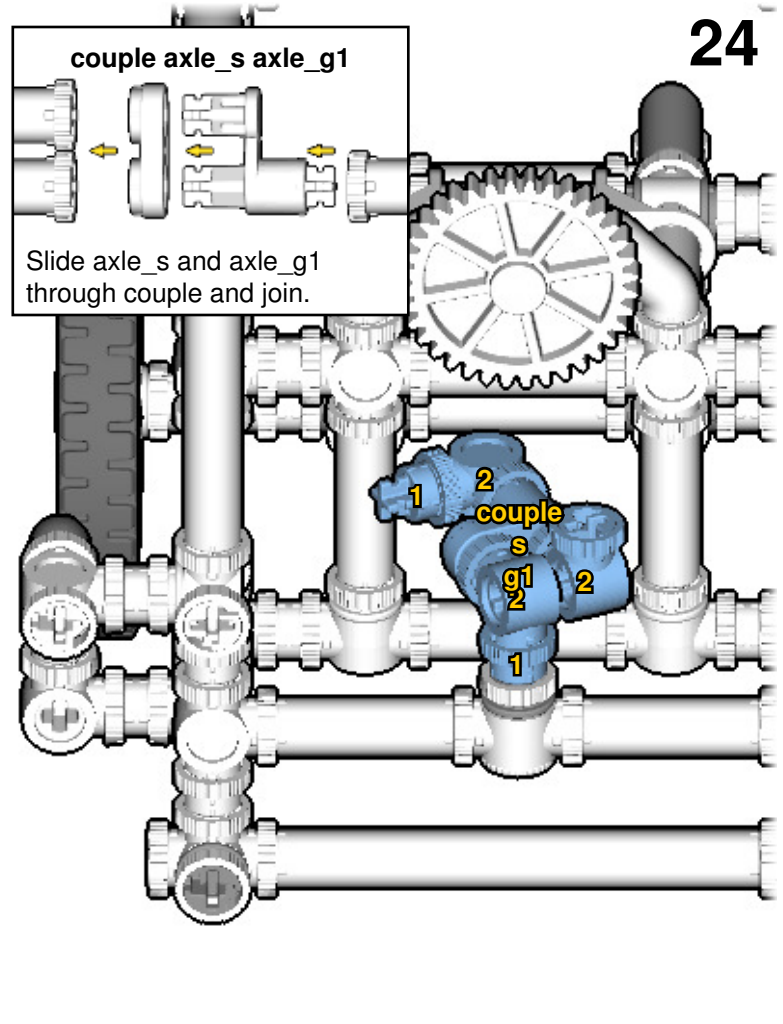
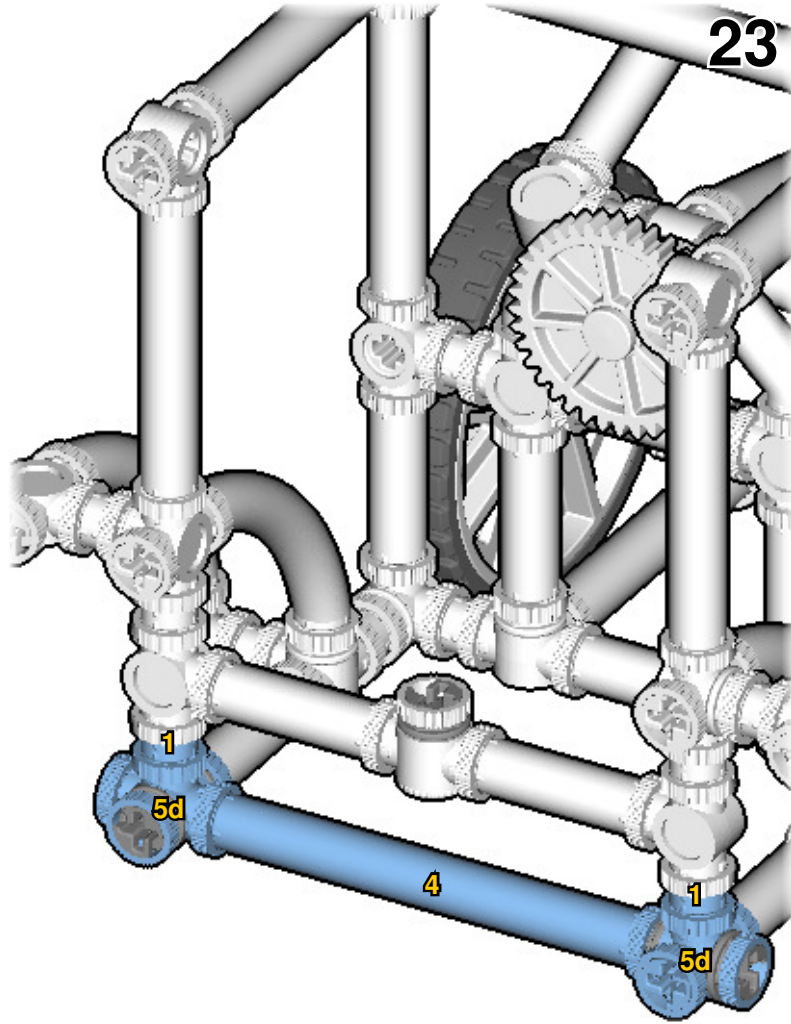

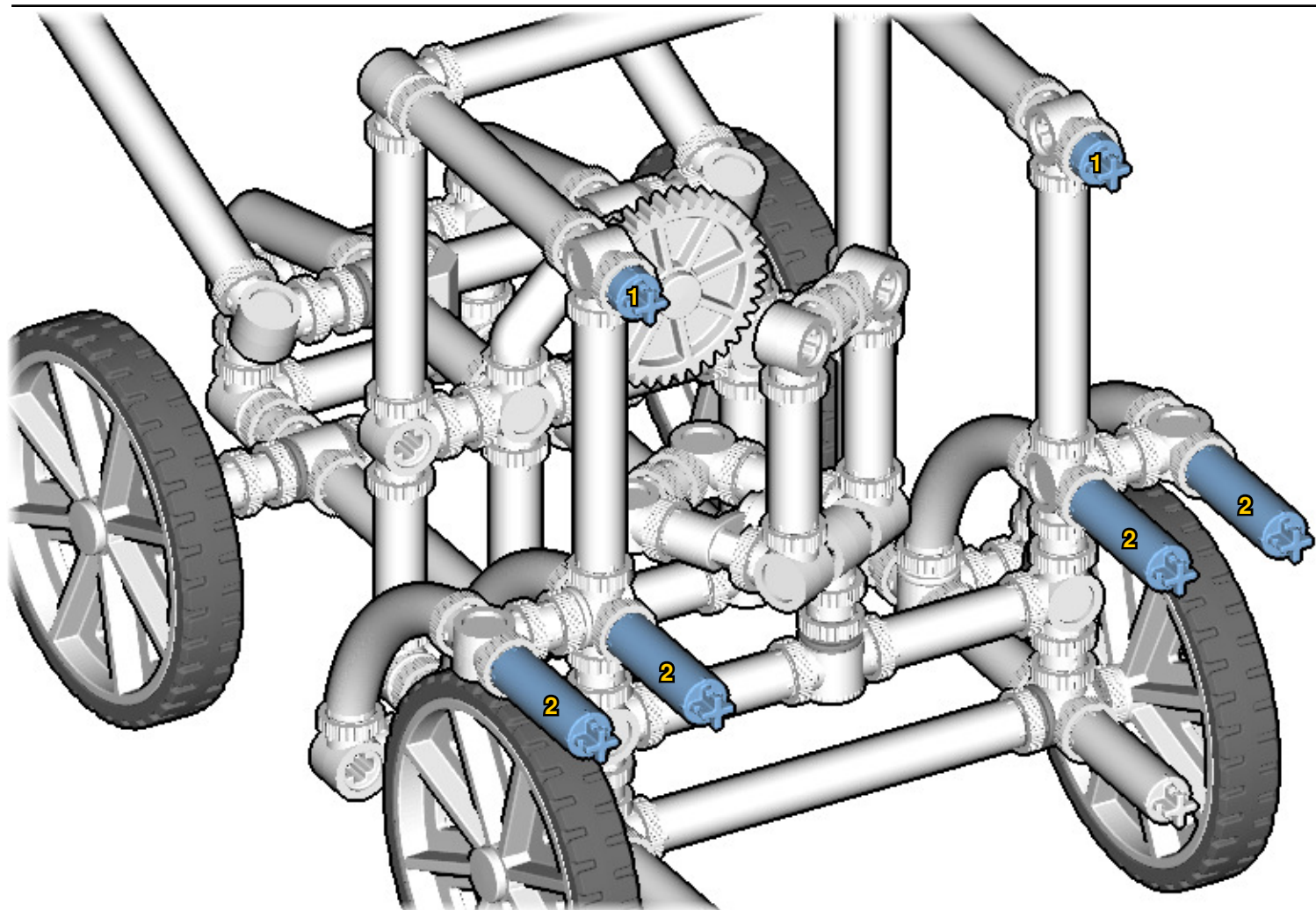
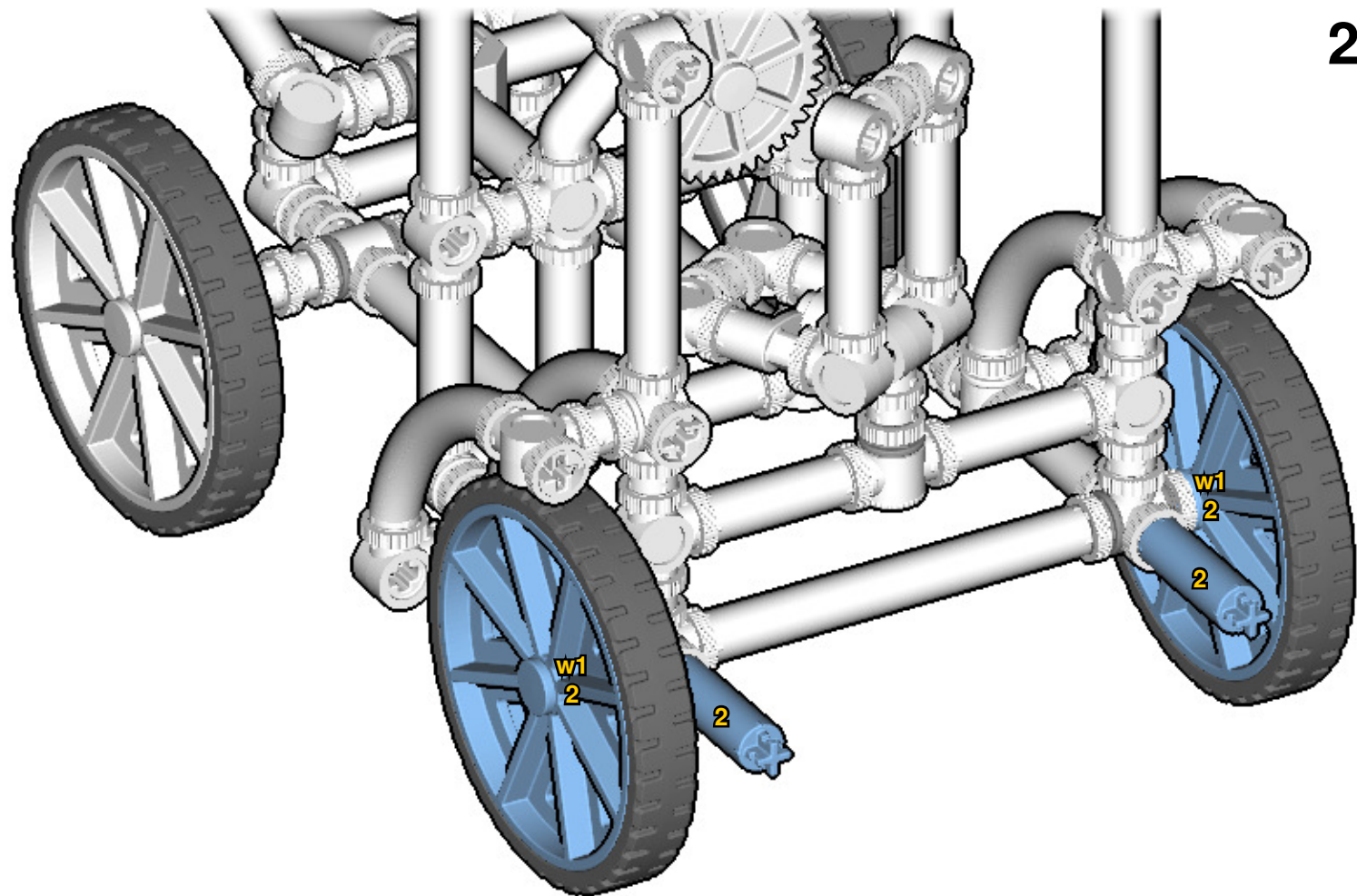

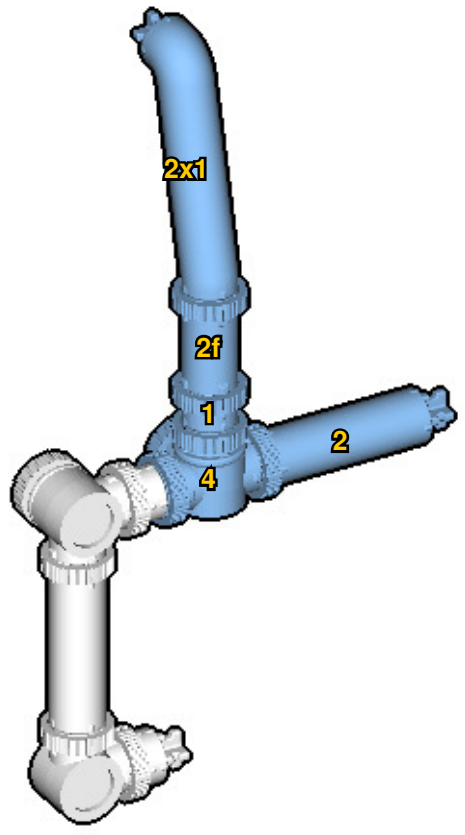
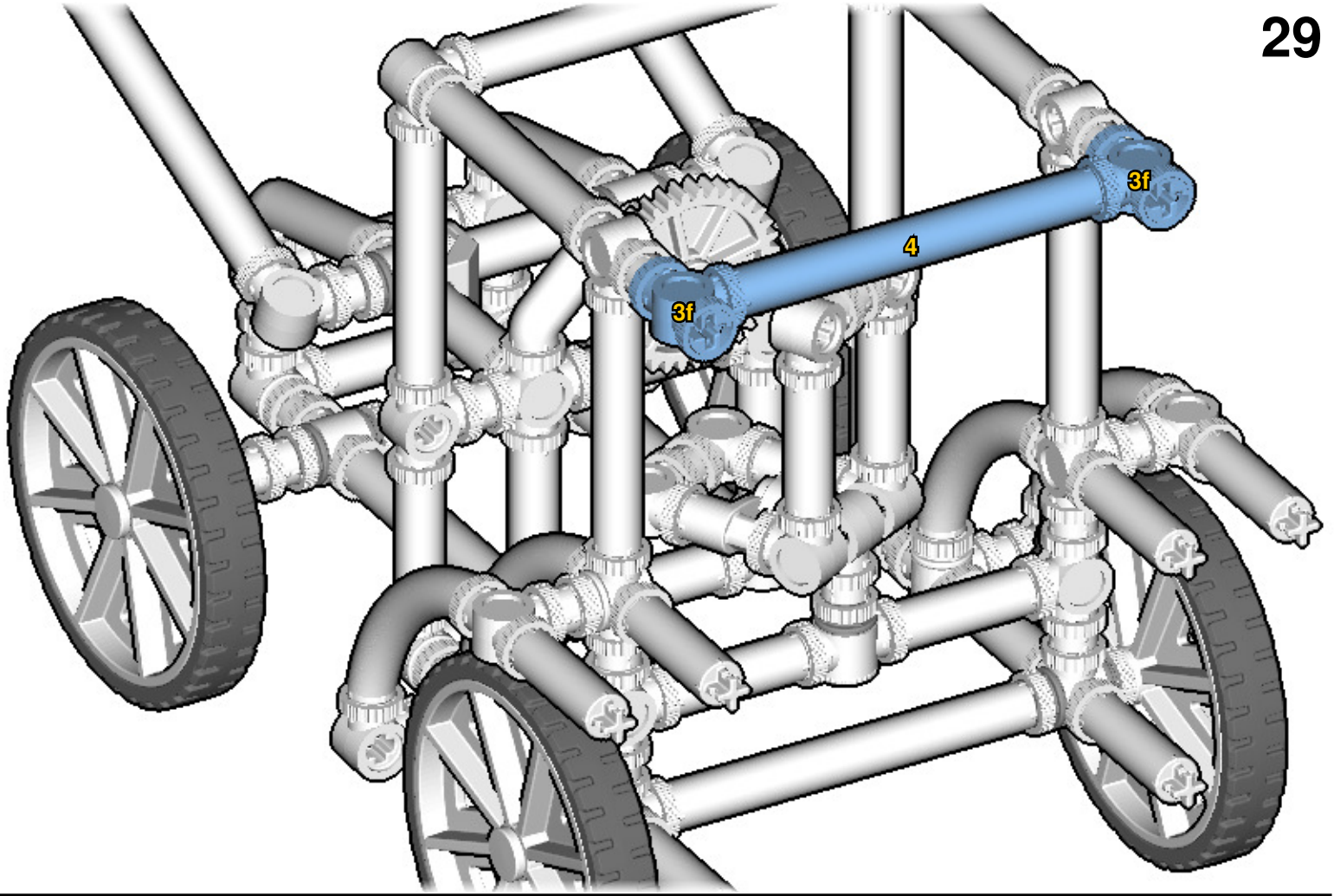



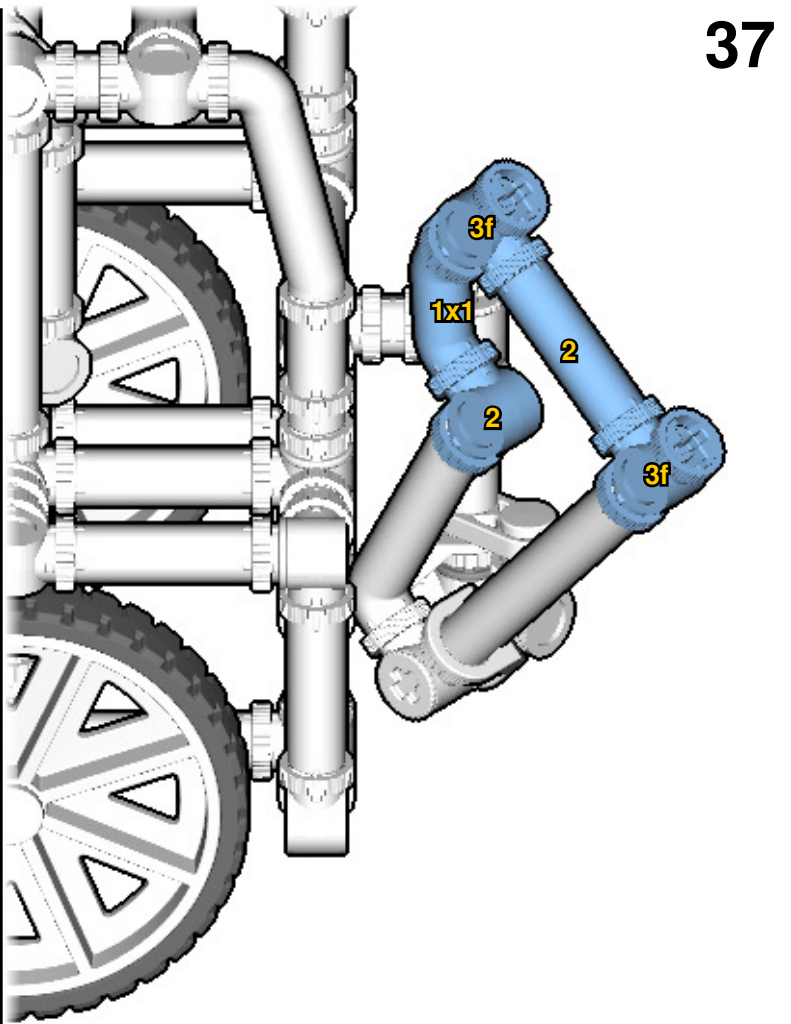
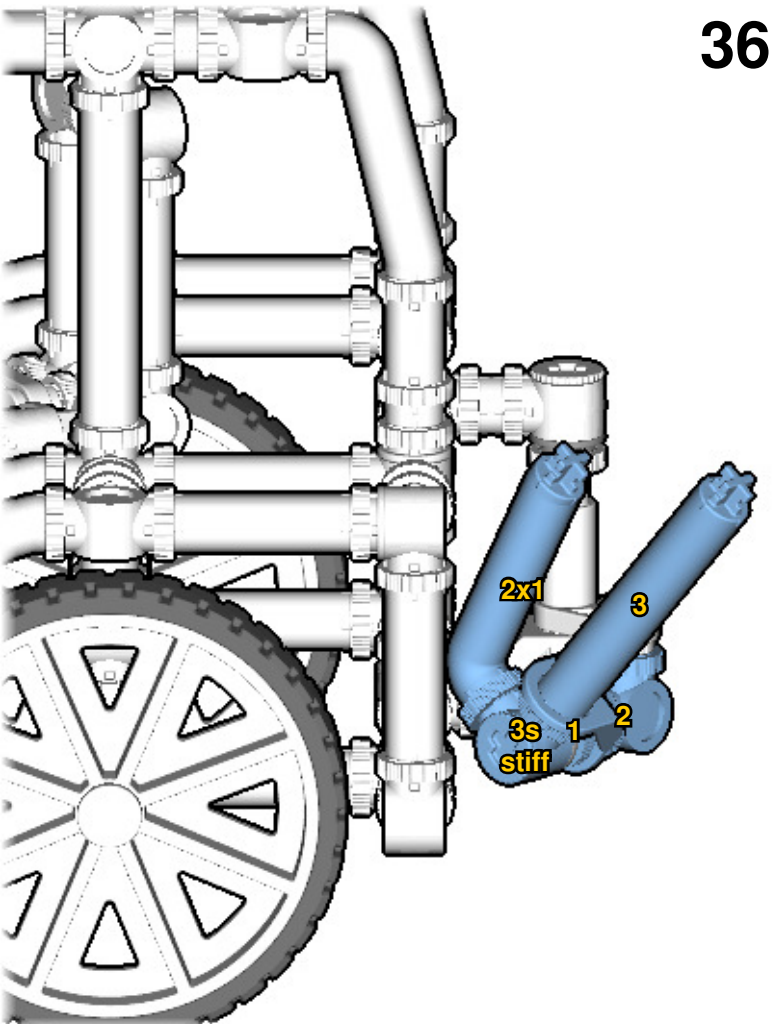
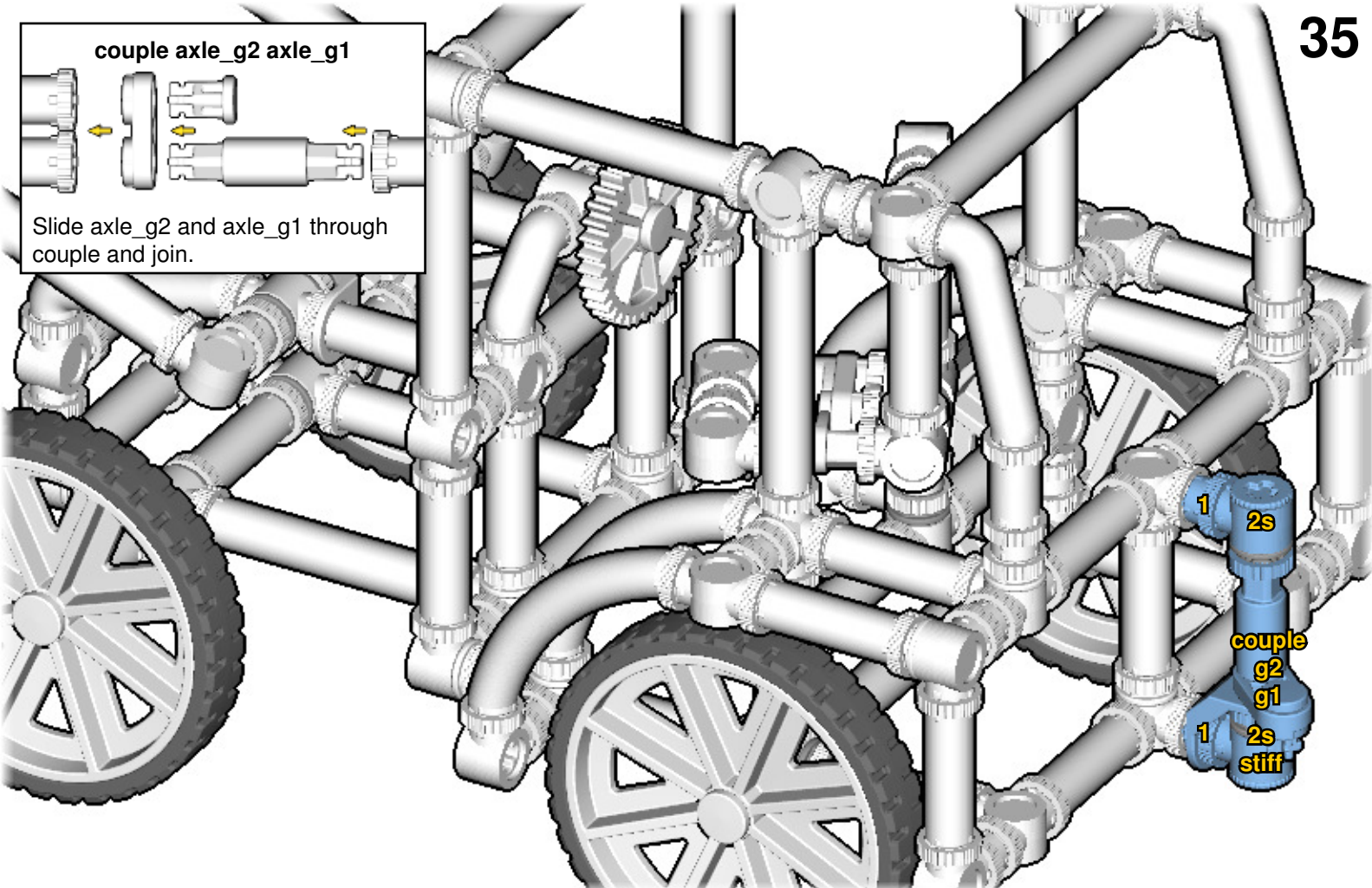
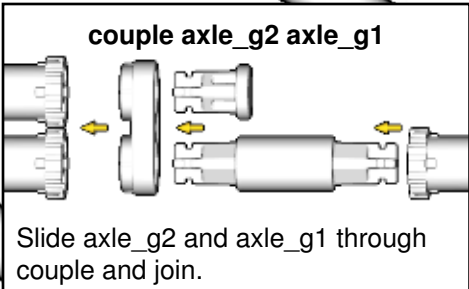

38

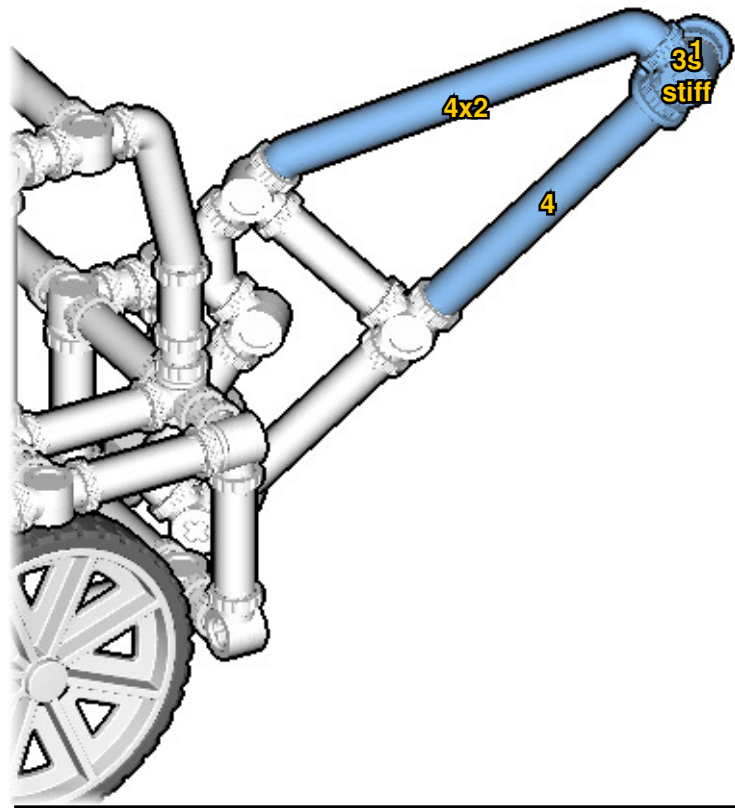

39

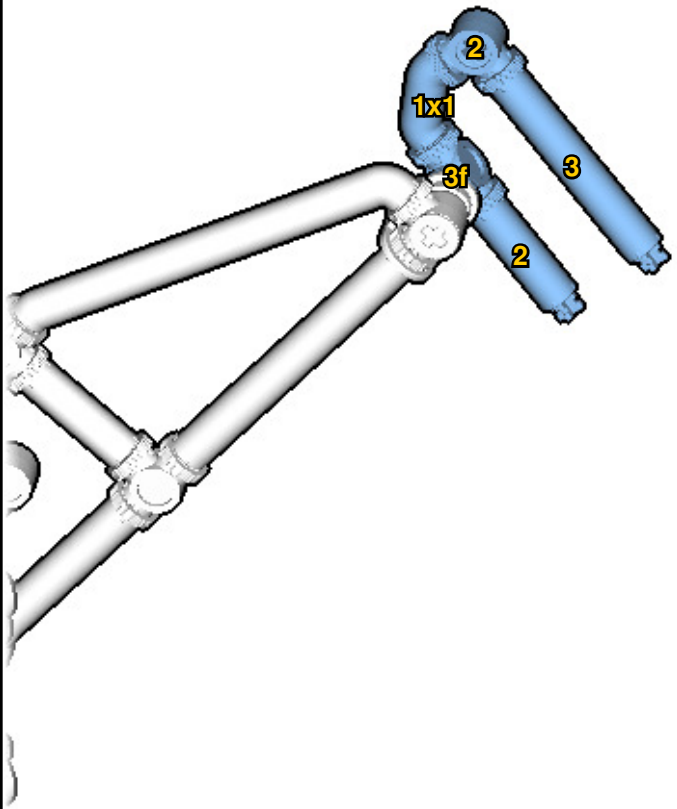

40

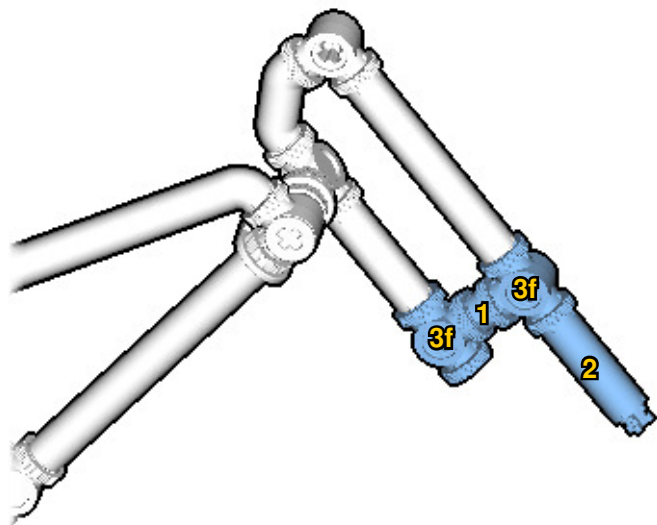

41

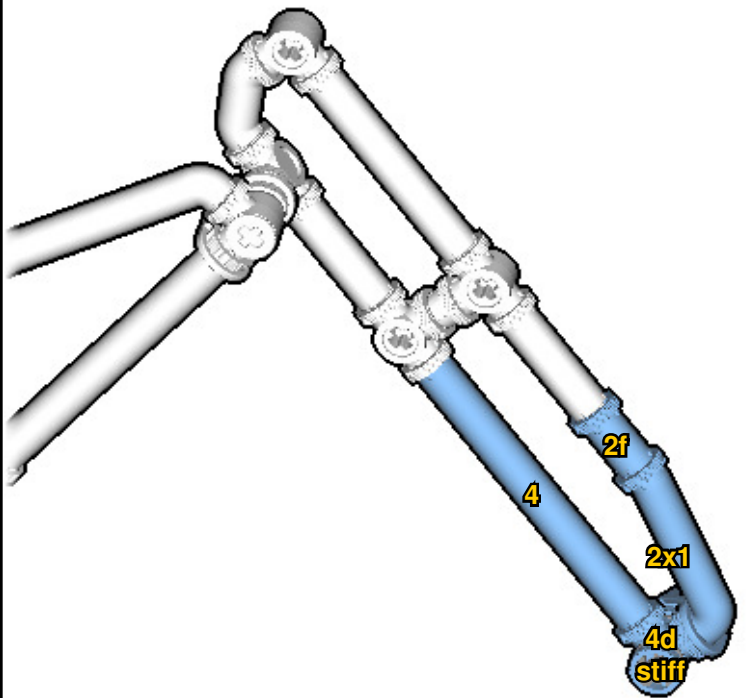

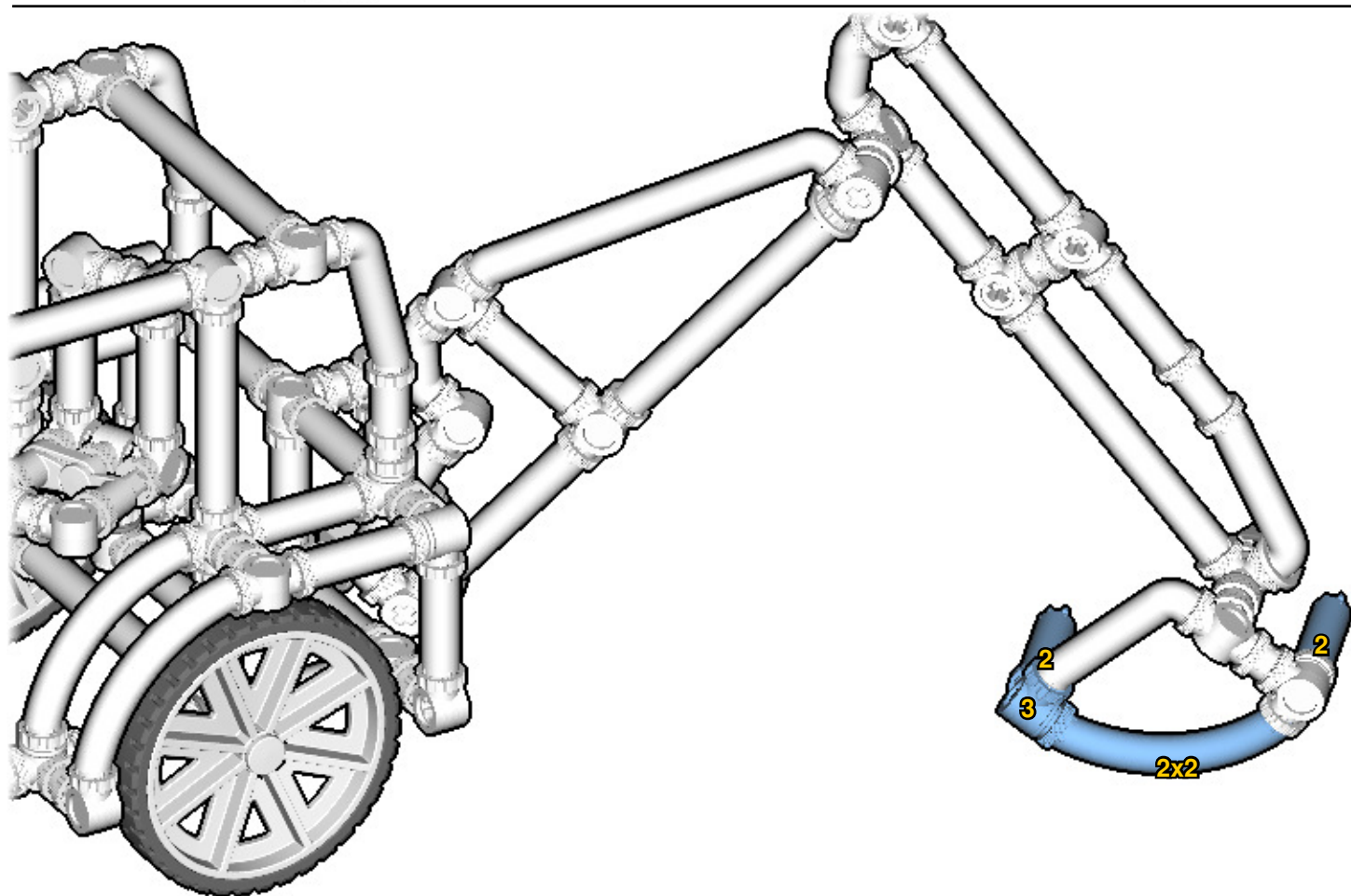
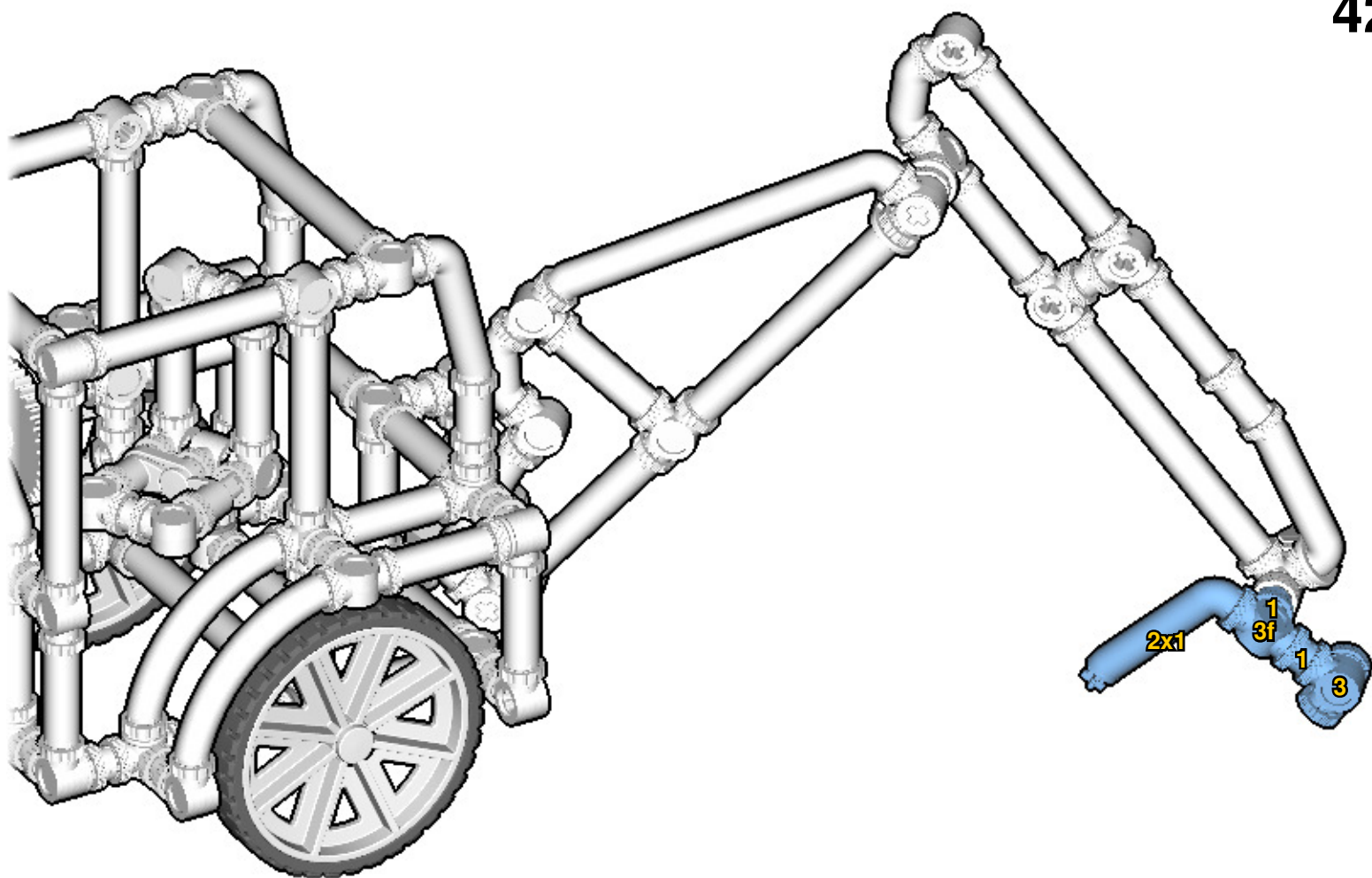

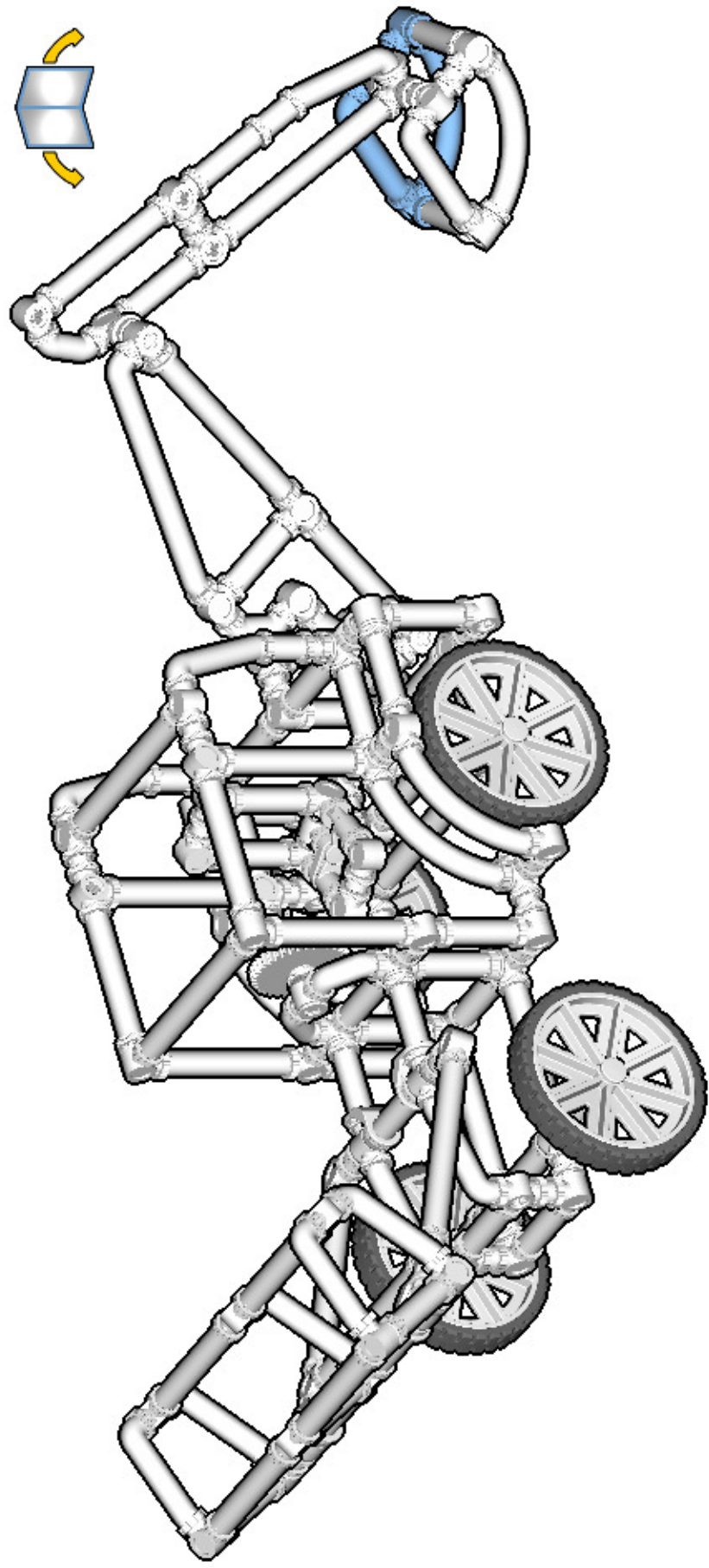



# INVENTORY

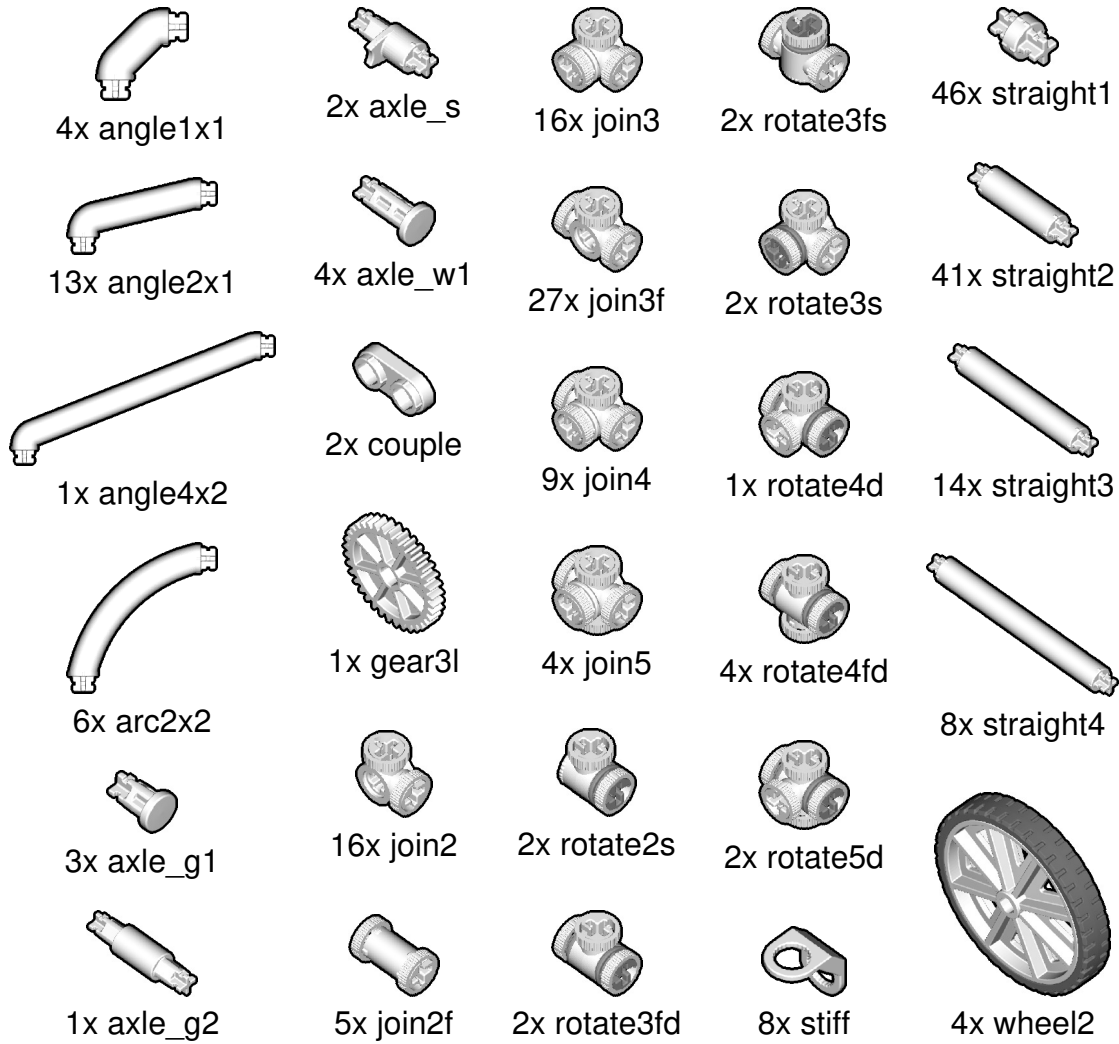

# ACTUAL SIZE

