

**CROSS
BEAMS™**

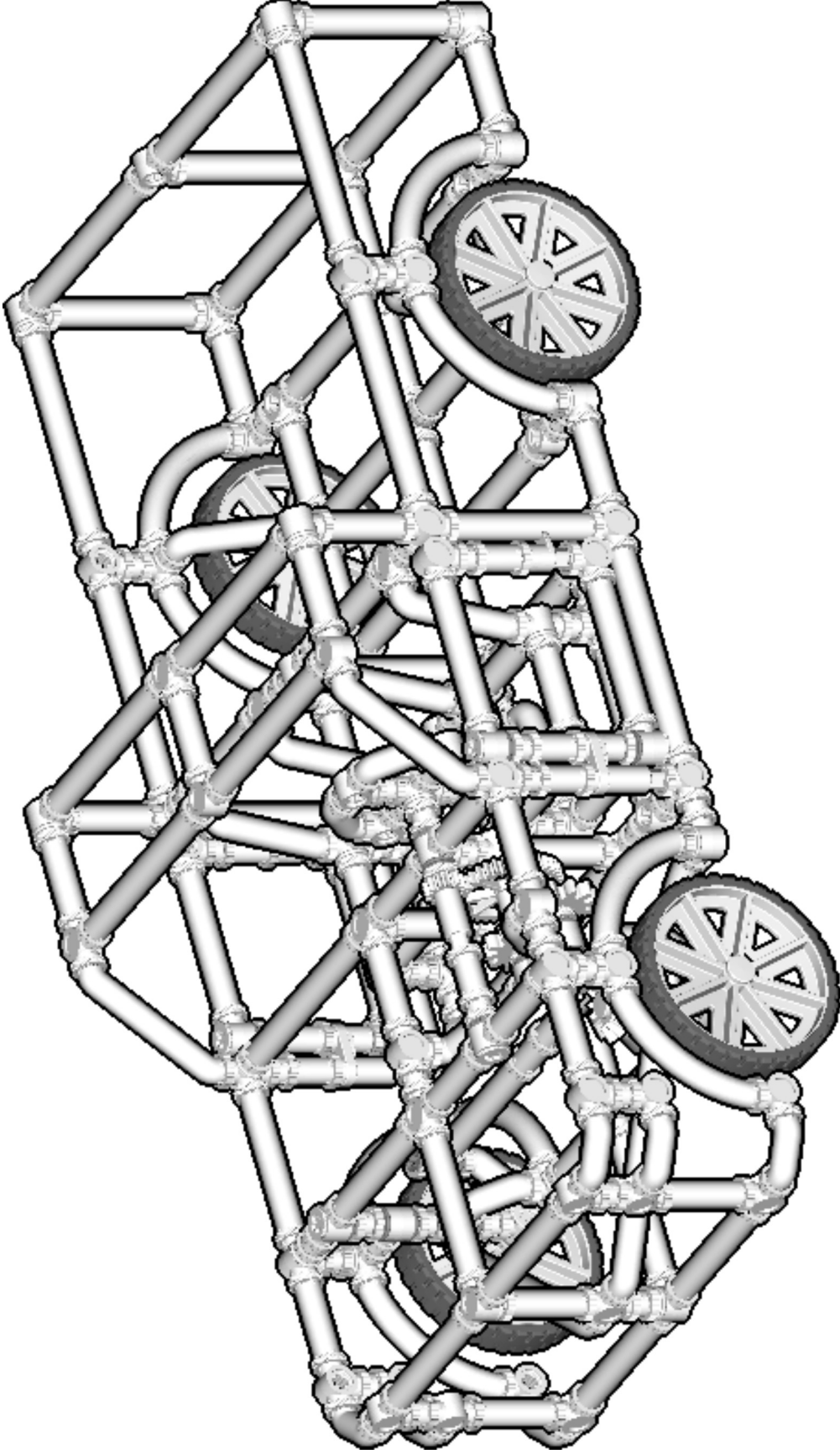

SIZE	1.3ft x 0.6ft x 0.4ft	PIECES	354
DESIGNER	Derek Sharman	MADE IN	U.S.A.

PICKUP

⚠ WARNING: Small parts. Age 14+. Not a toy. Handle responsibly. U.S. Patent 9,086,087.



Wrong
Connecting/Disconnecting Two Directions



Right
Connecting/Disconnecting One Direction

1



New pieces are drawn blue. Old pieces are drawn white.
See back for piece names.

2

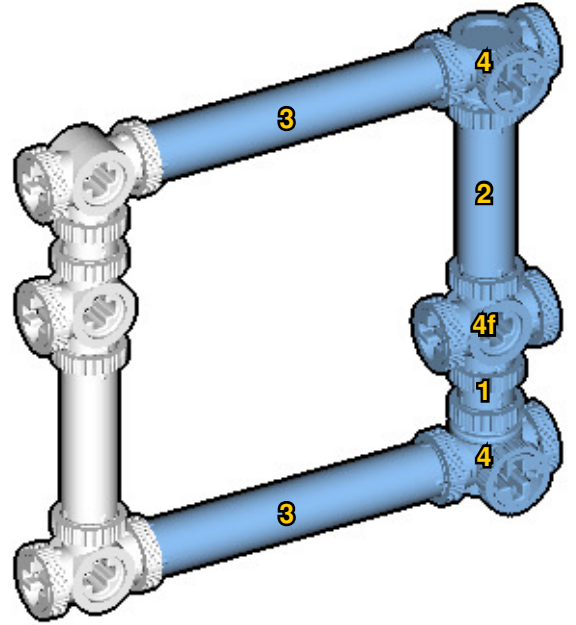

Connect new pieces together before connecting to old pieces.

3

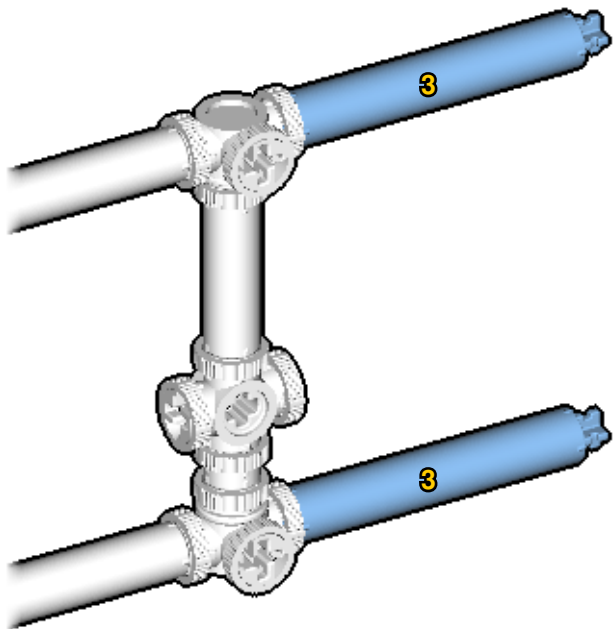

4

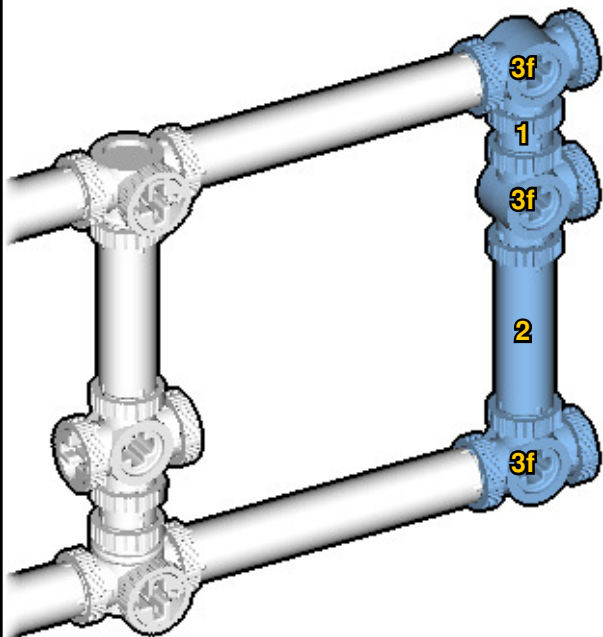

5

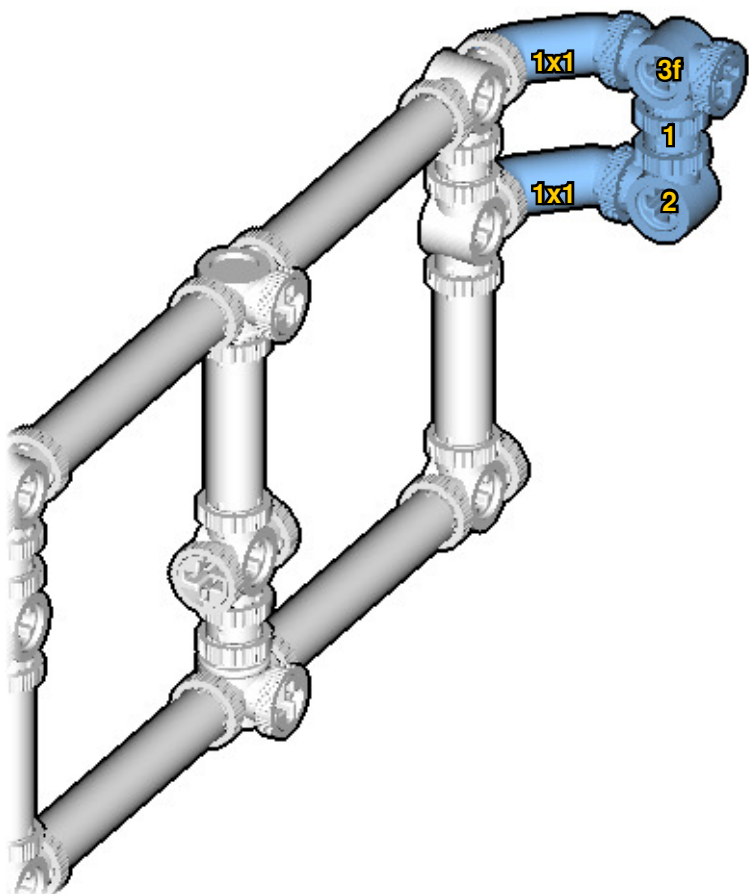

6

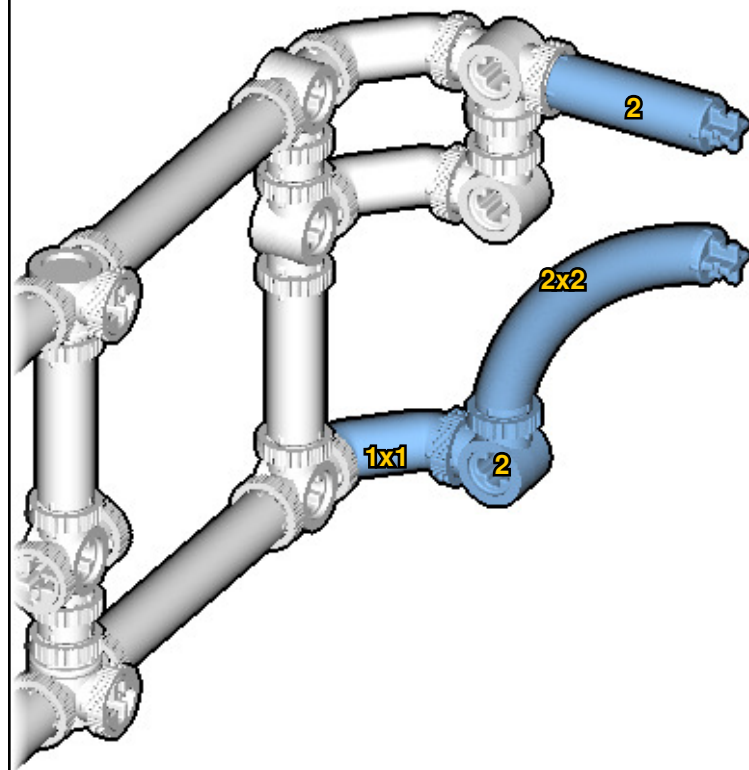

7

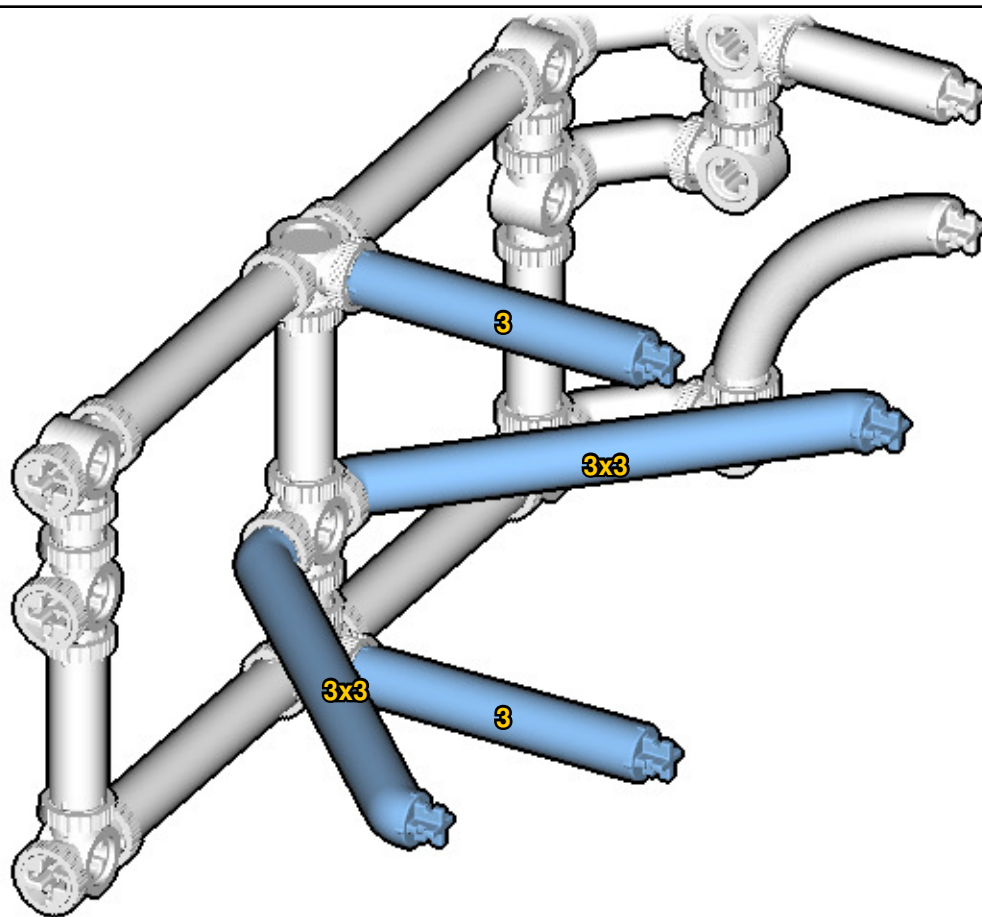

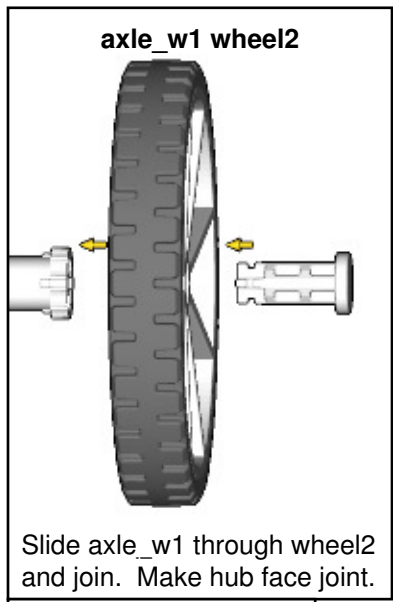
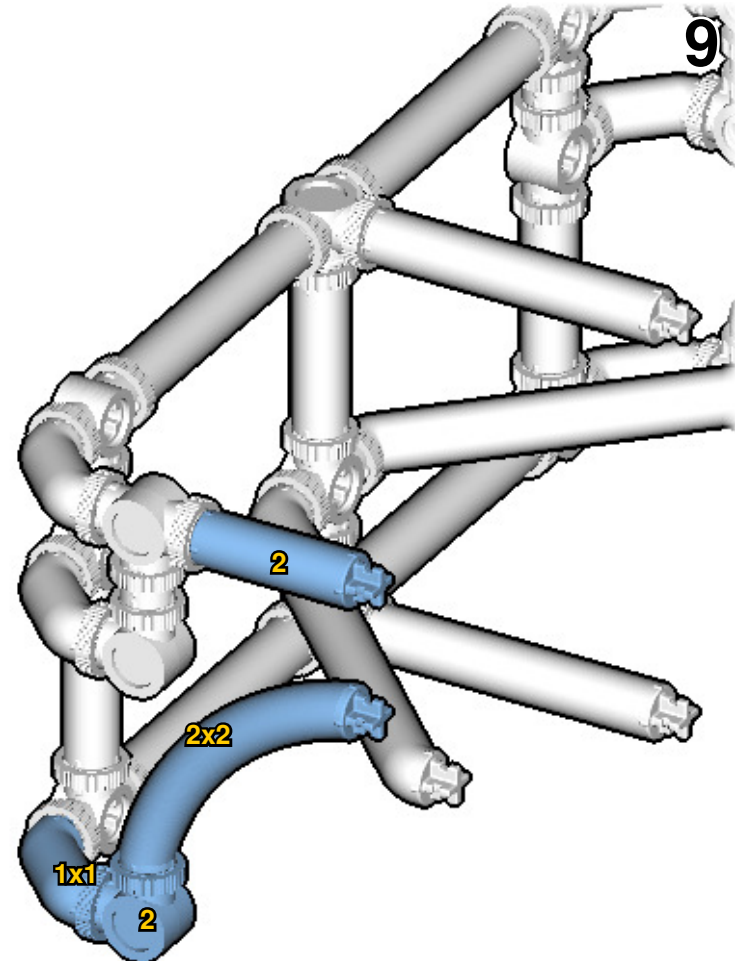
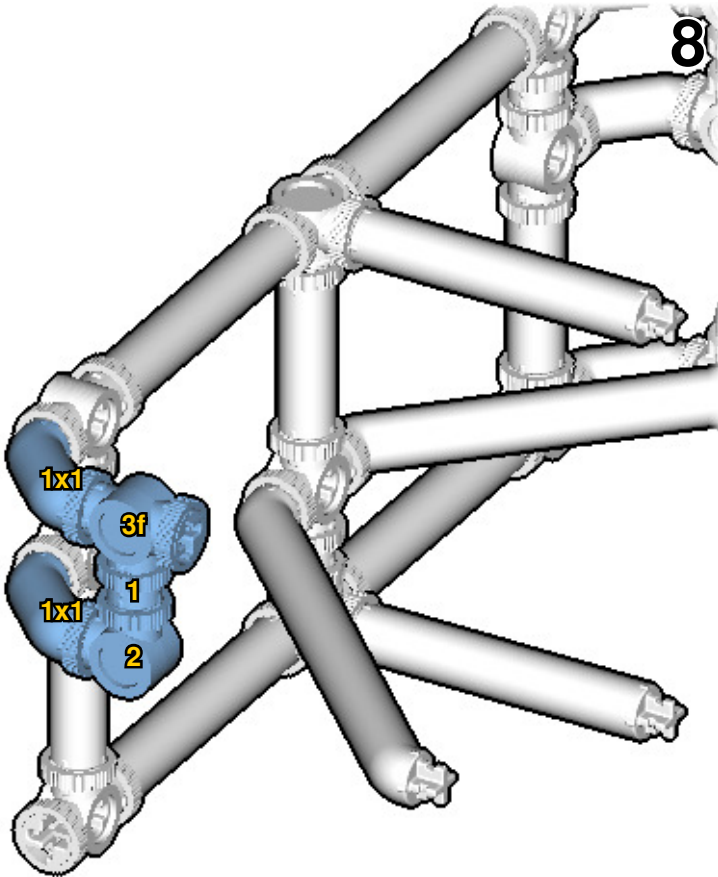

Submodel begins → **10**

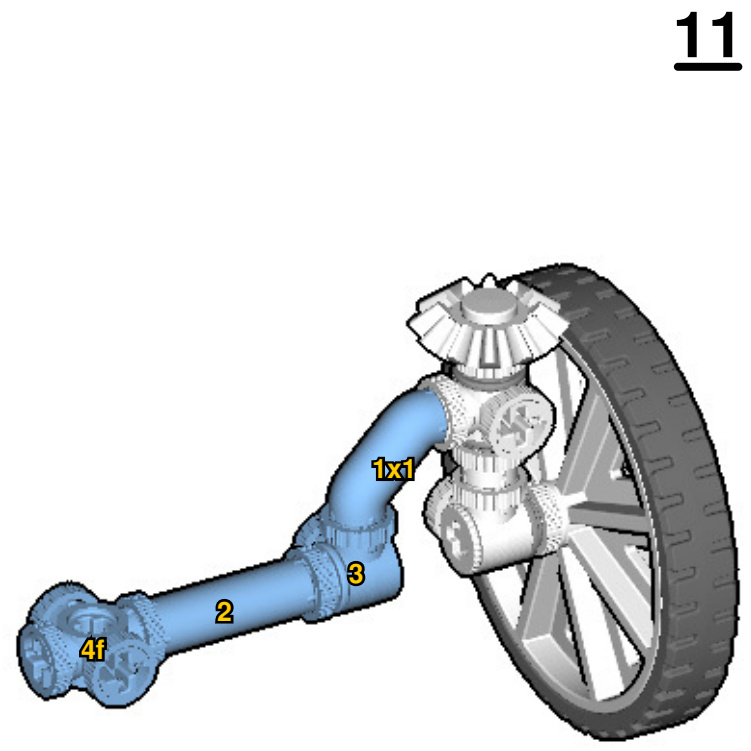
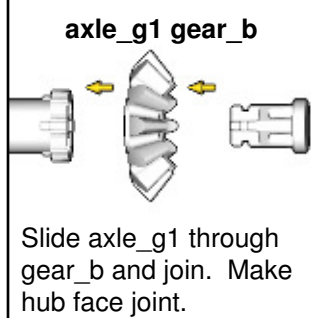
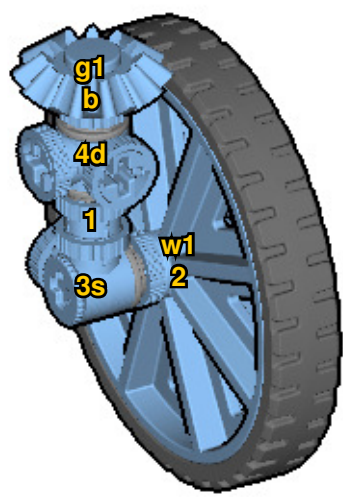

12

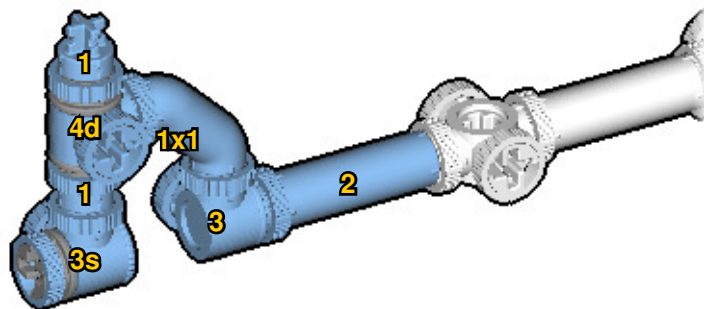

13

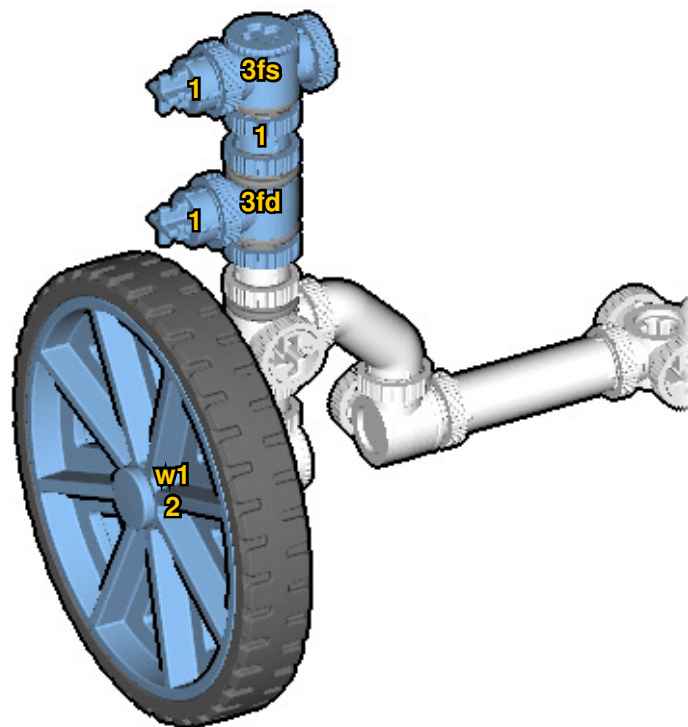

14

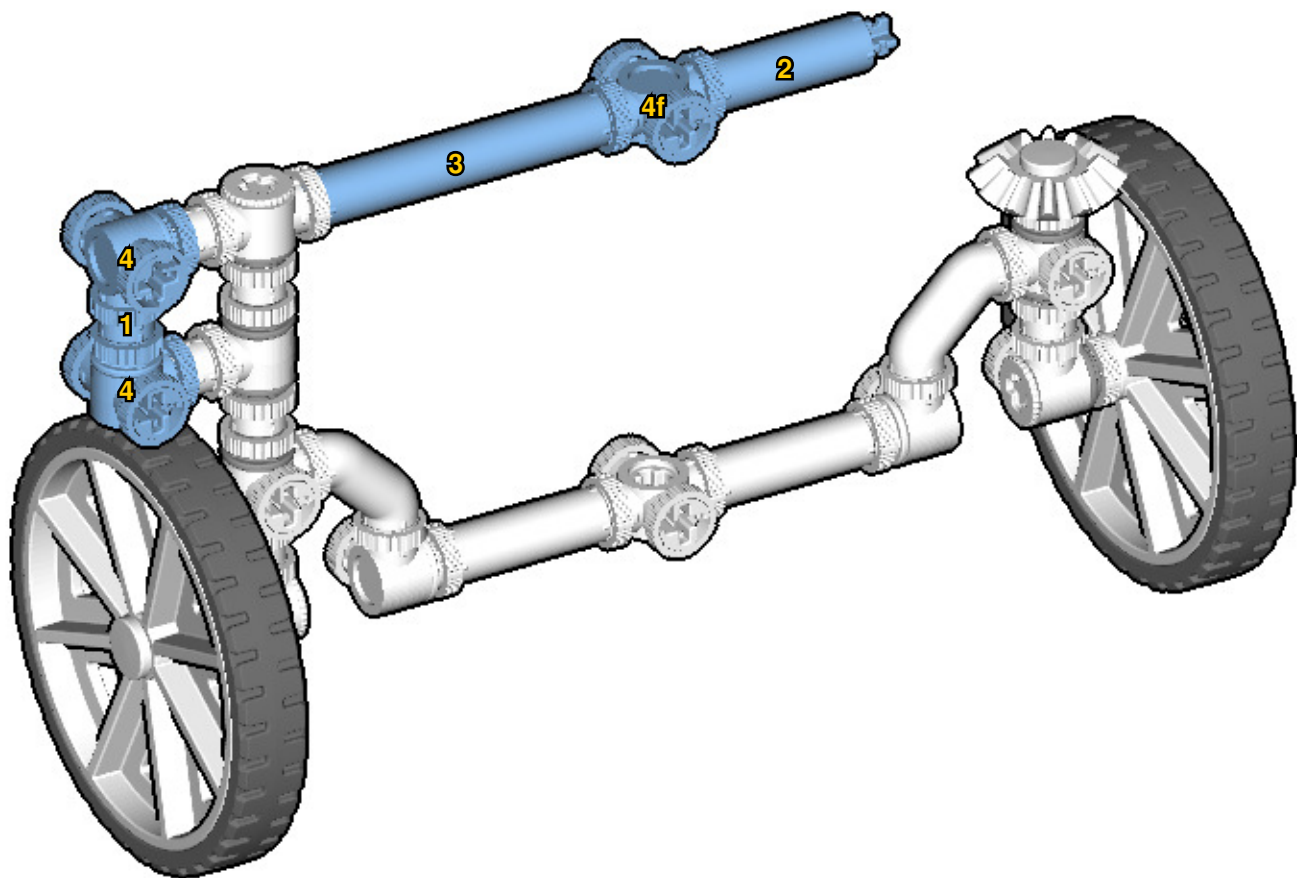

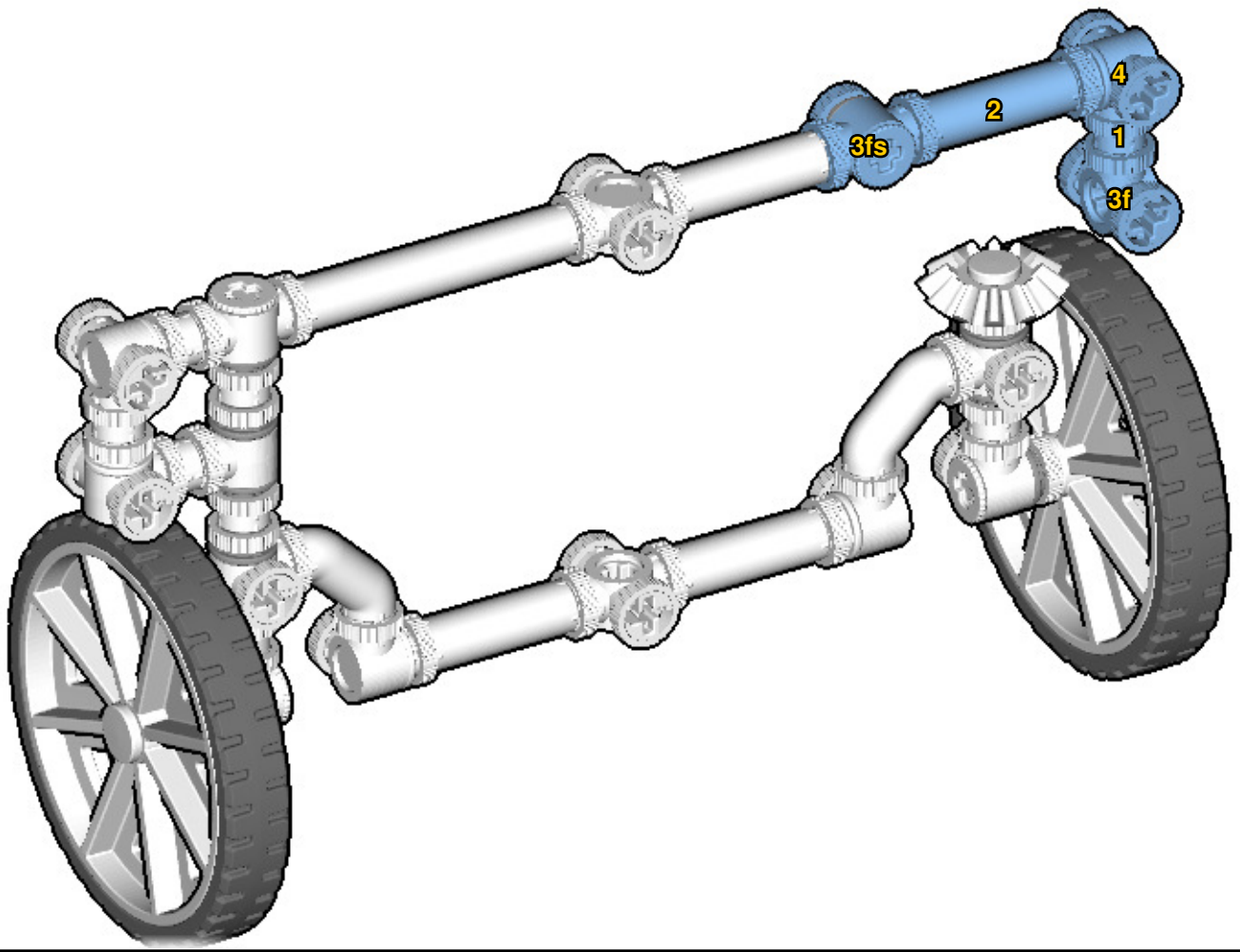

Submodel ends → 16

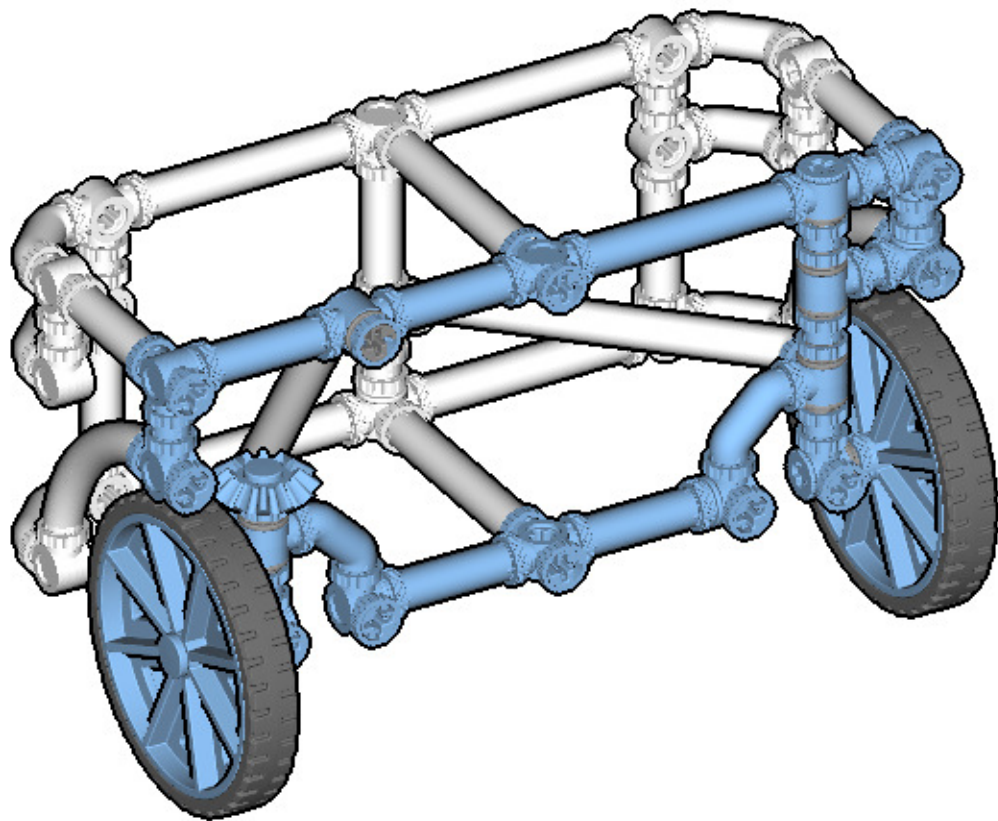

Connect submodel to model.

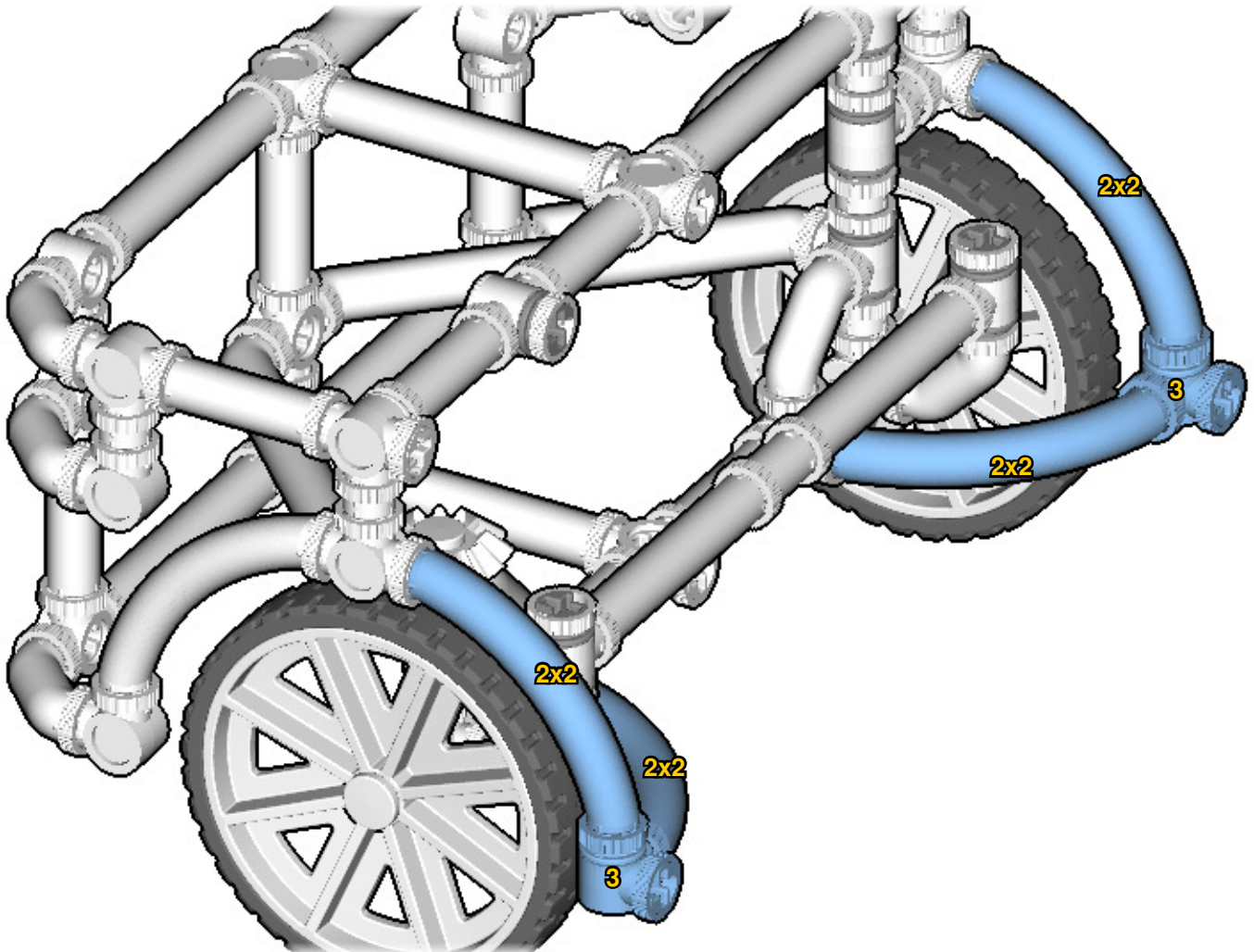
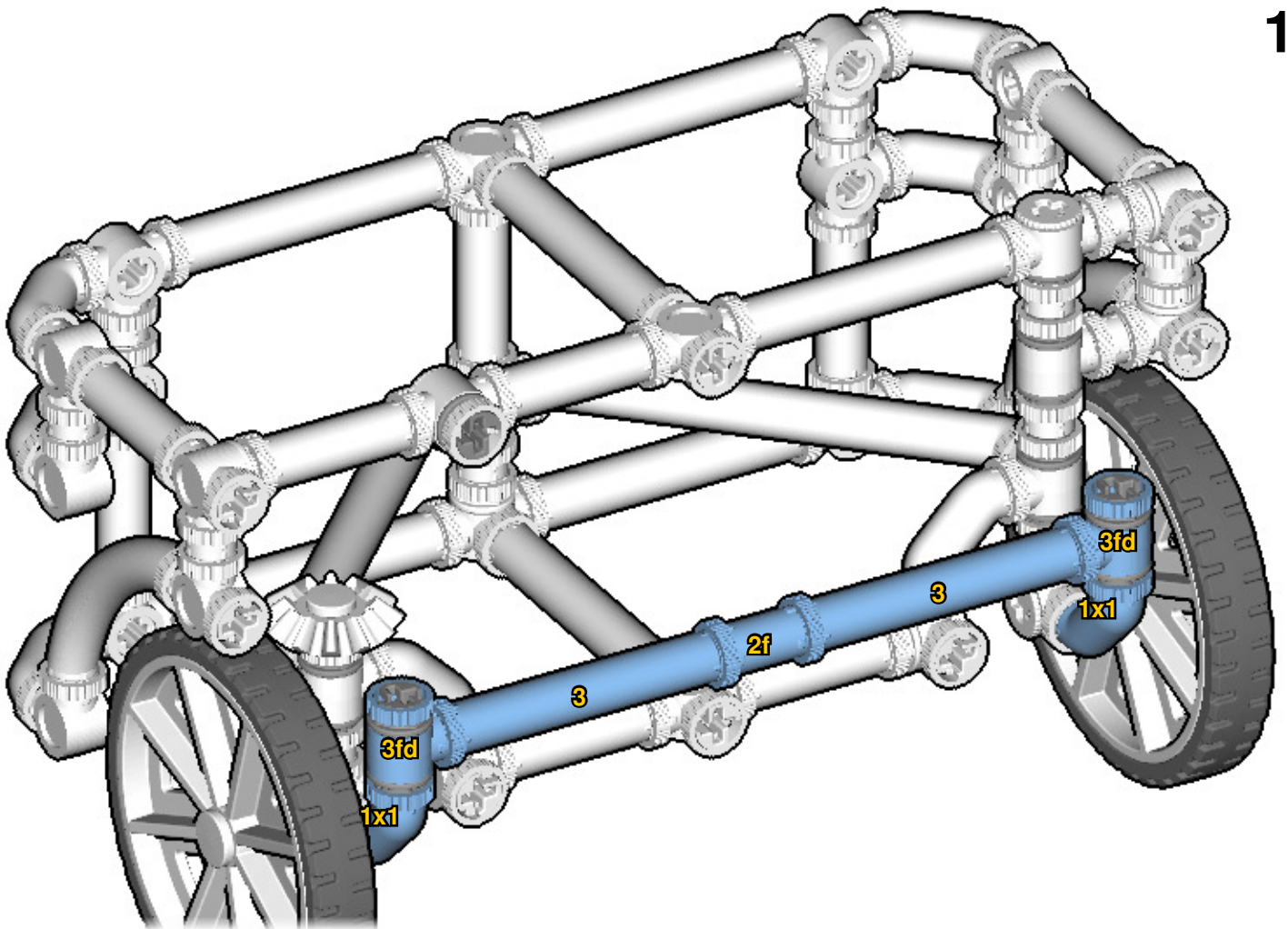

19

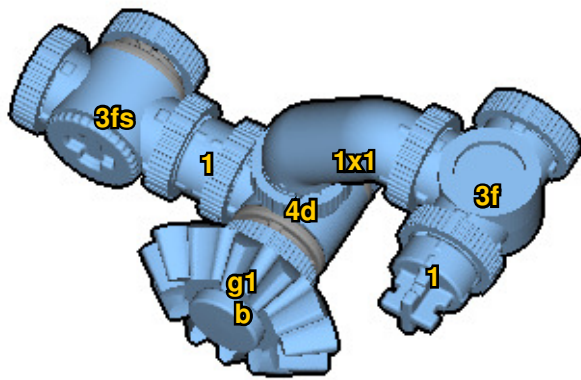

20

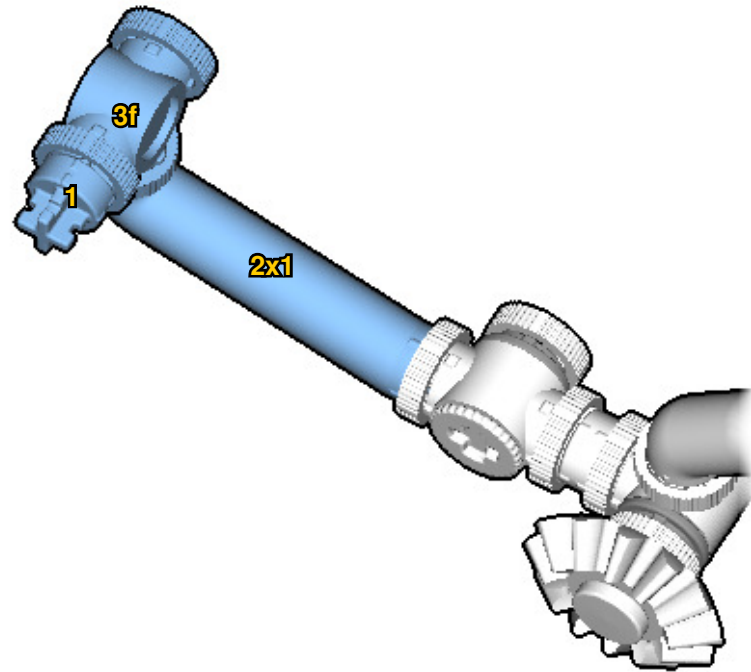

21

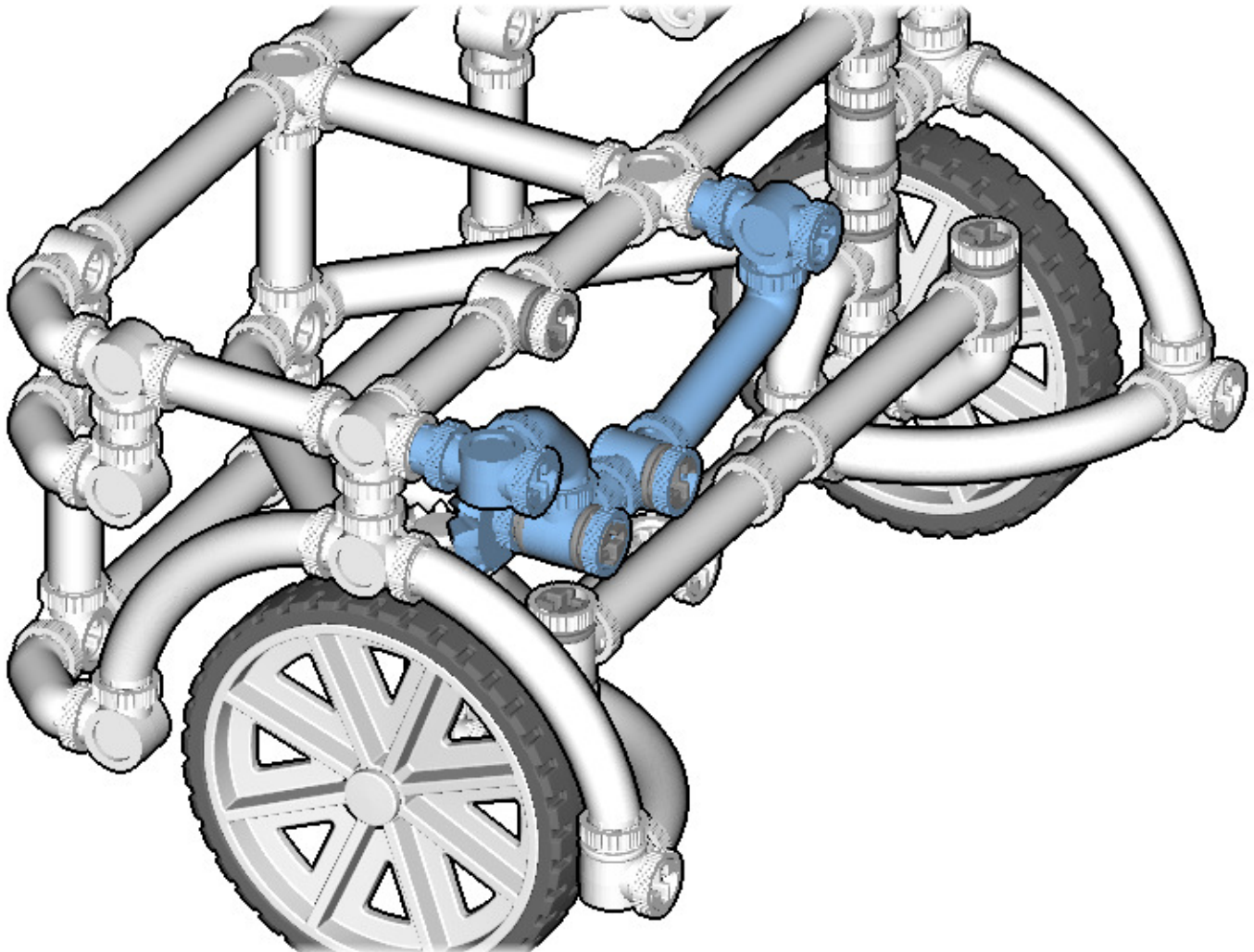

axle_g2 gear3l gear1

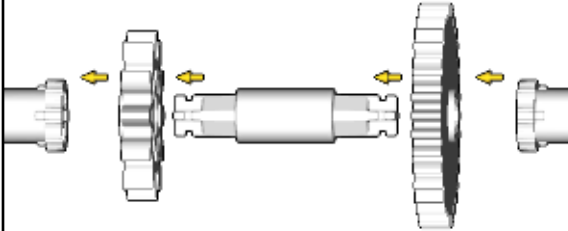

Slide axle_g2 through gear1 and gear3l and join. Make hub face joint.

axle_g2 gear3s



Slide axle_g2 through gear3s and join. Make hub face joint.

axle_g1 gear1

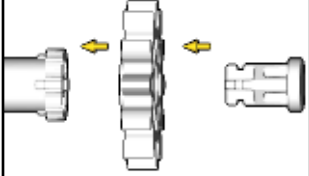

Slide axle_g1 through gear1 and join. Make hub face joint.

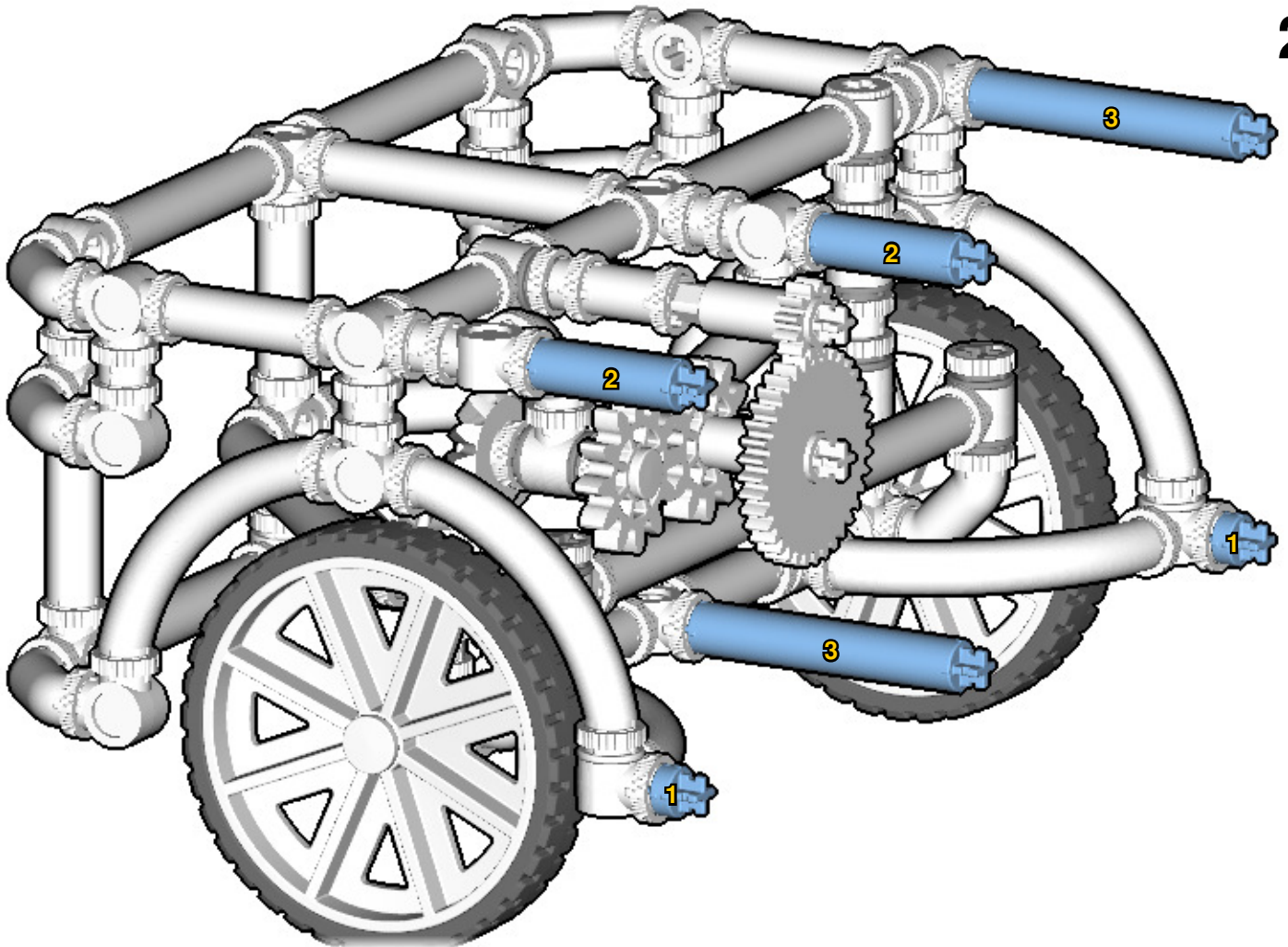
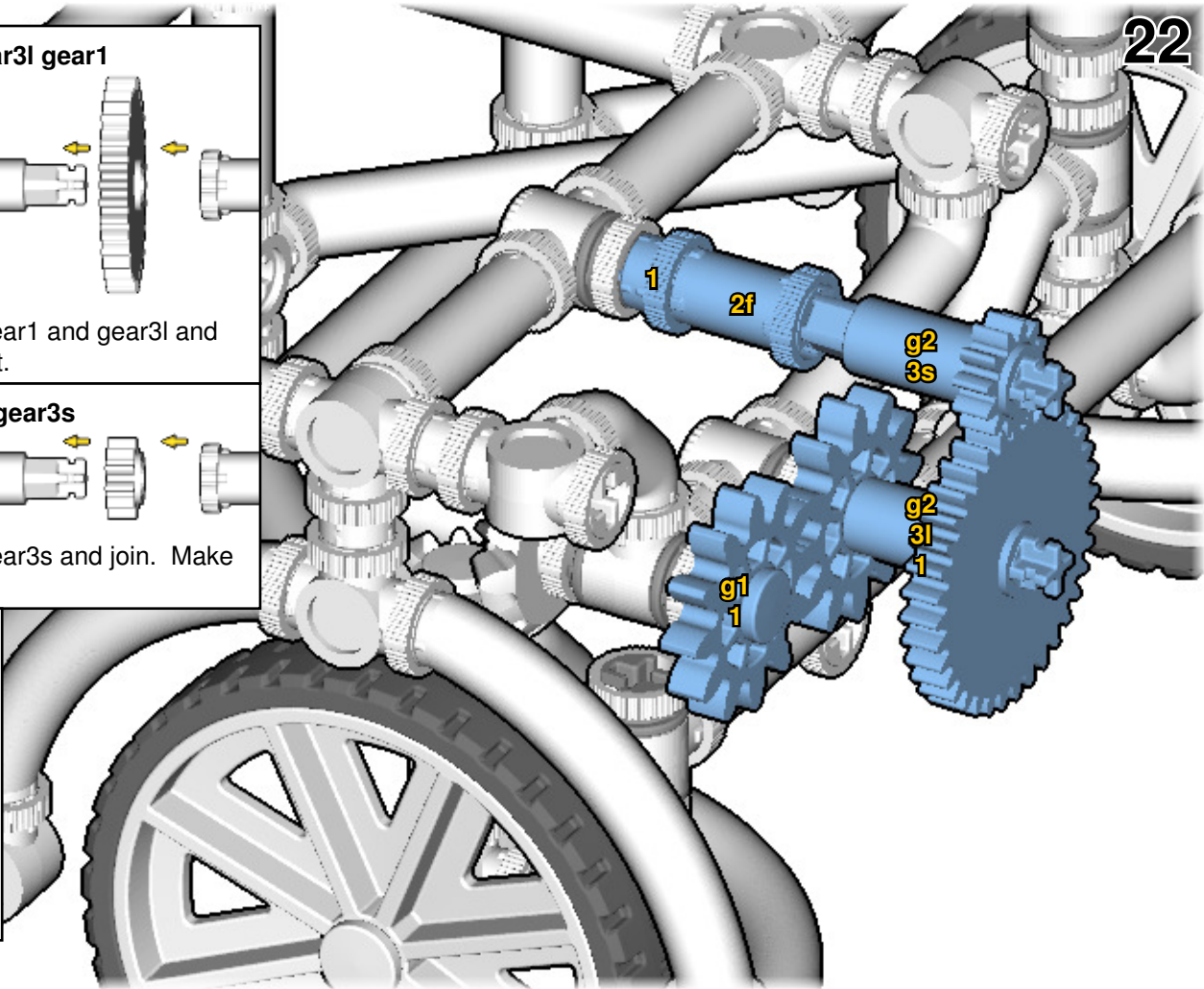

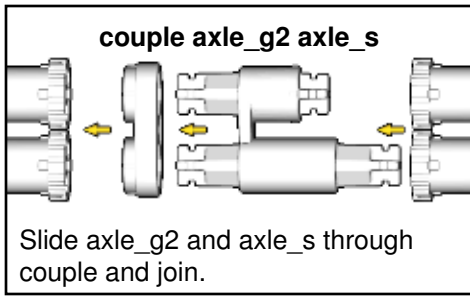

24



25

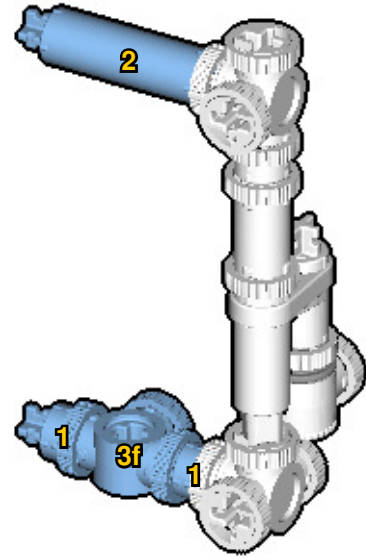

26

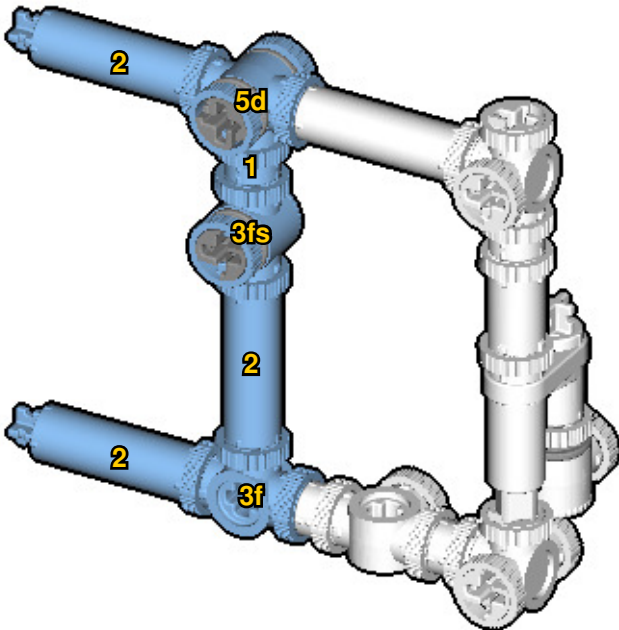

27

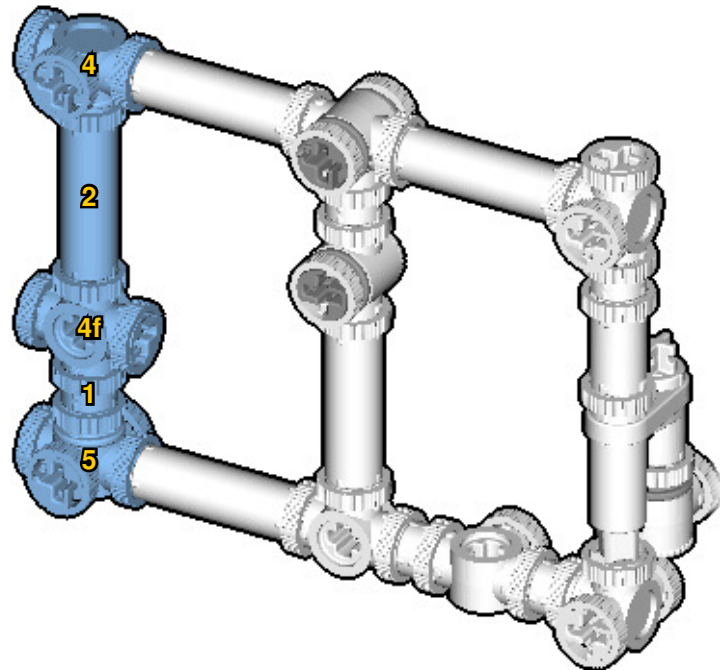

28

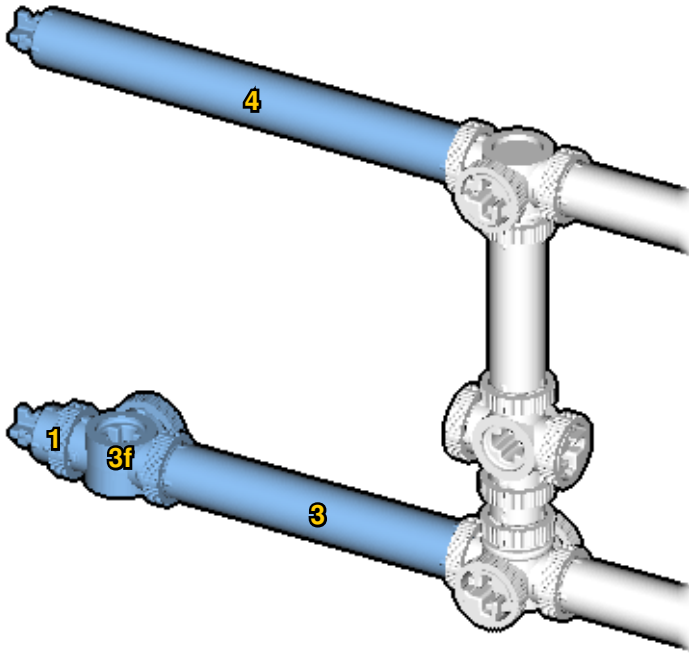

29

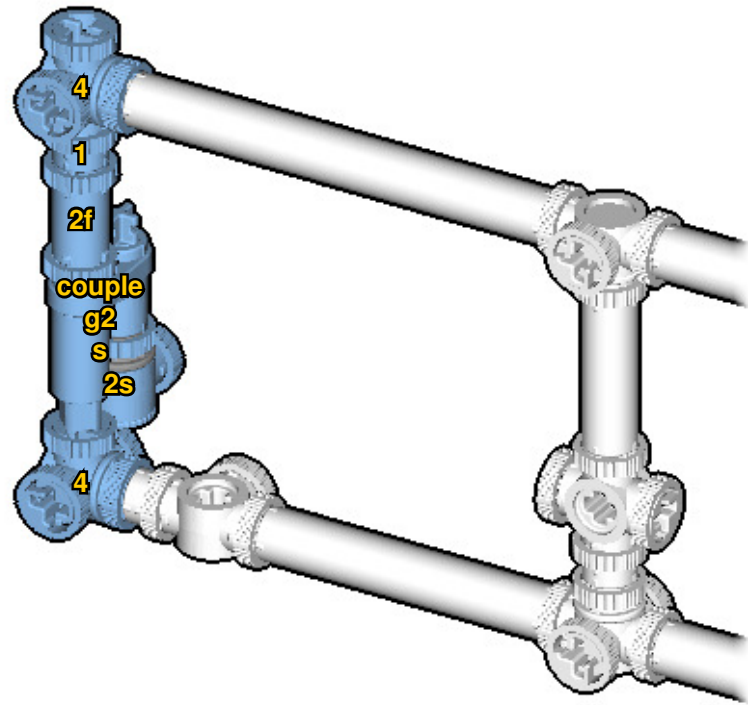

30

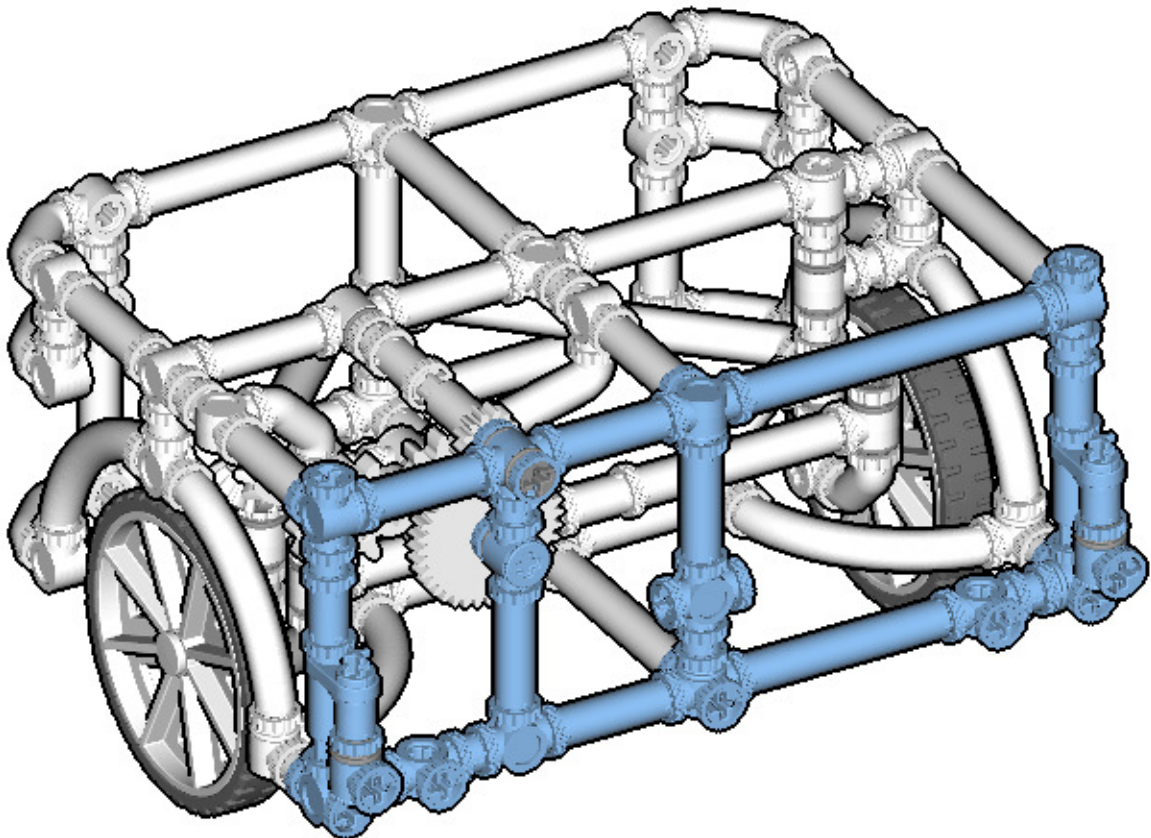

31

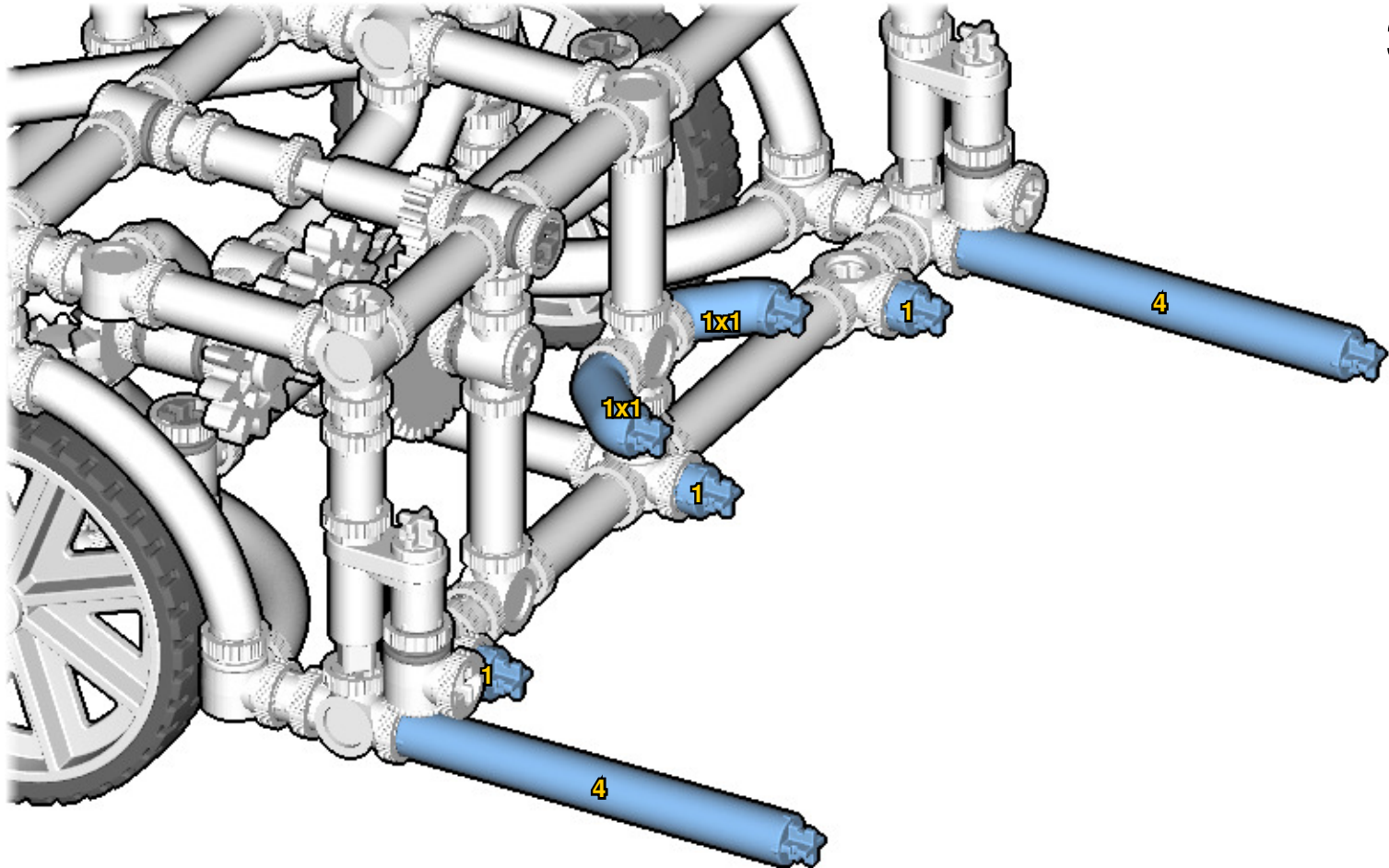

32

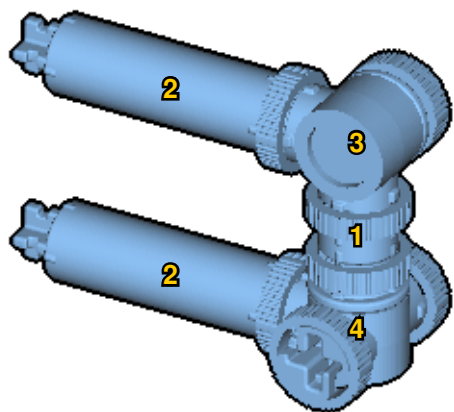

33

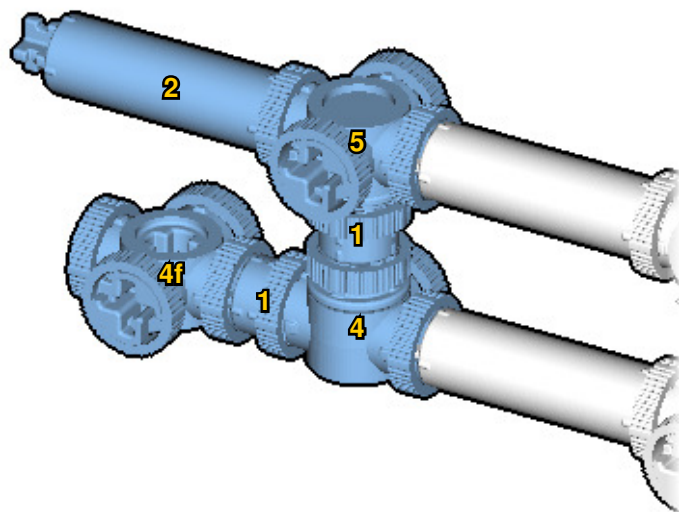

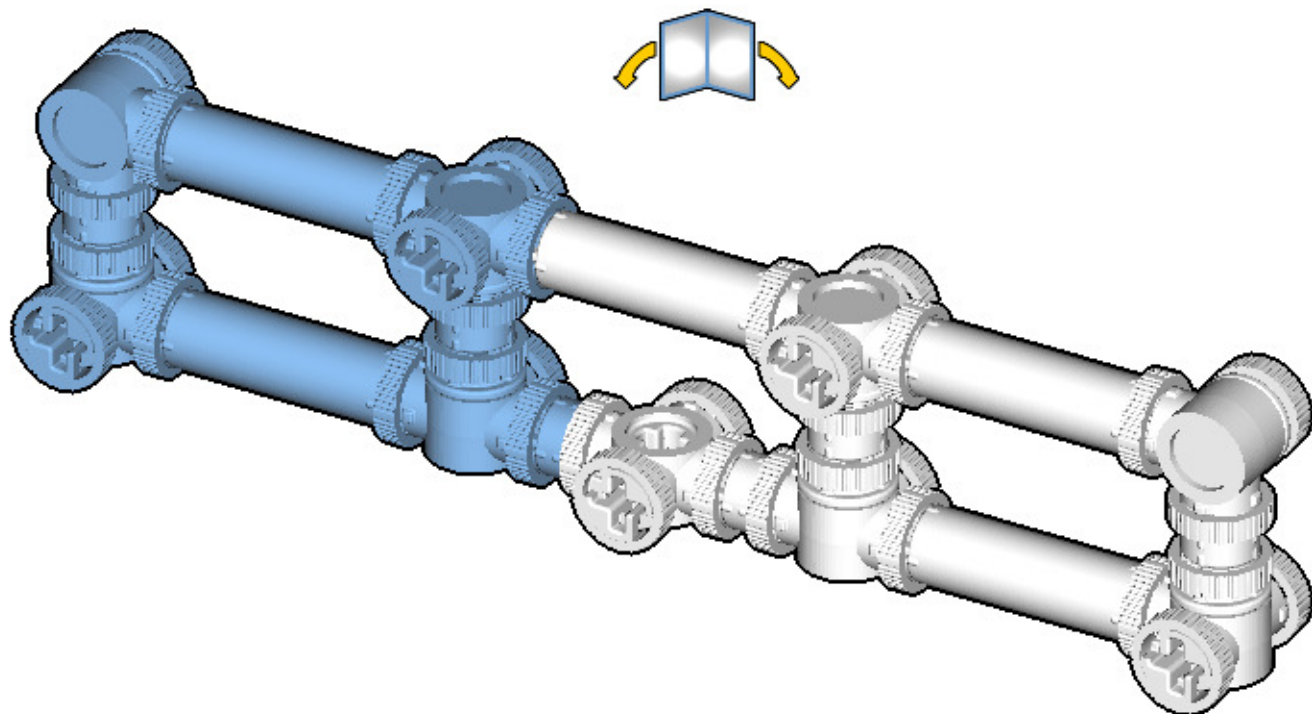

 : Copy new pieces from old pieces.

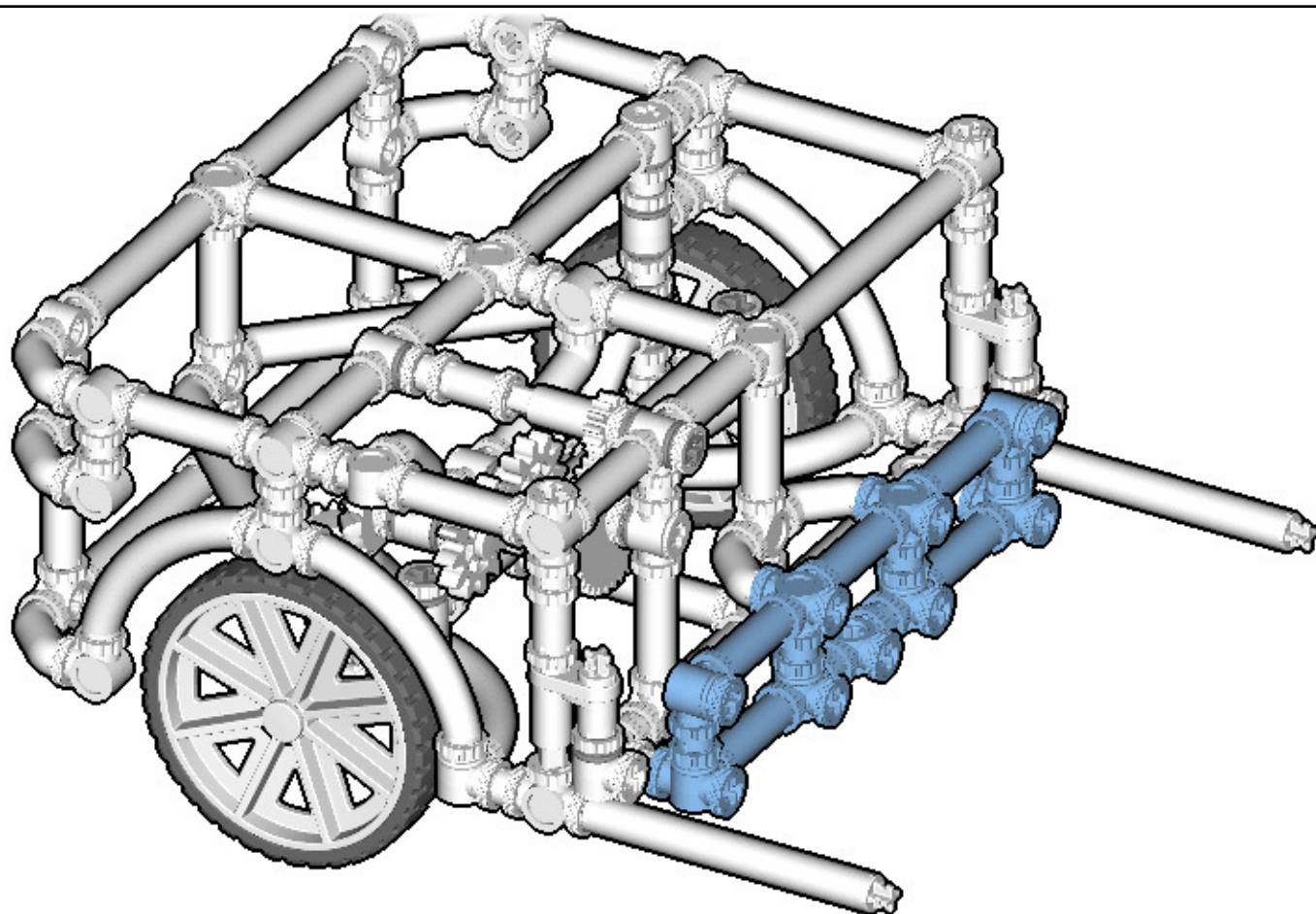

36

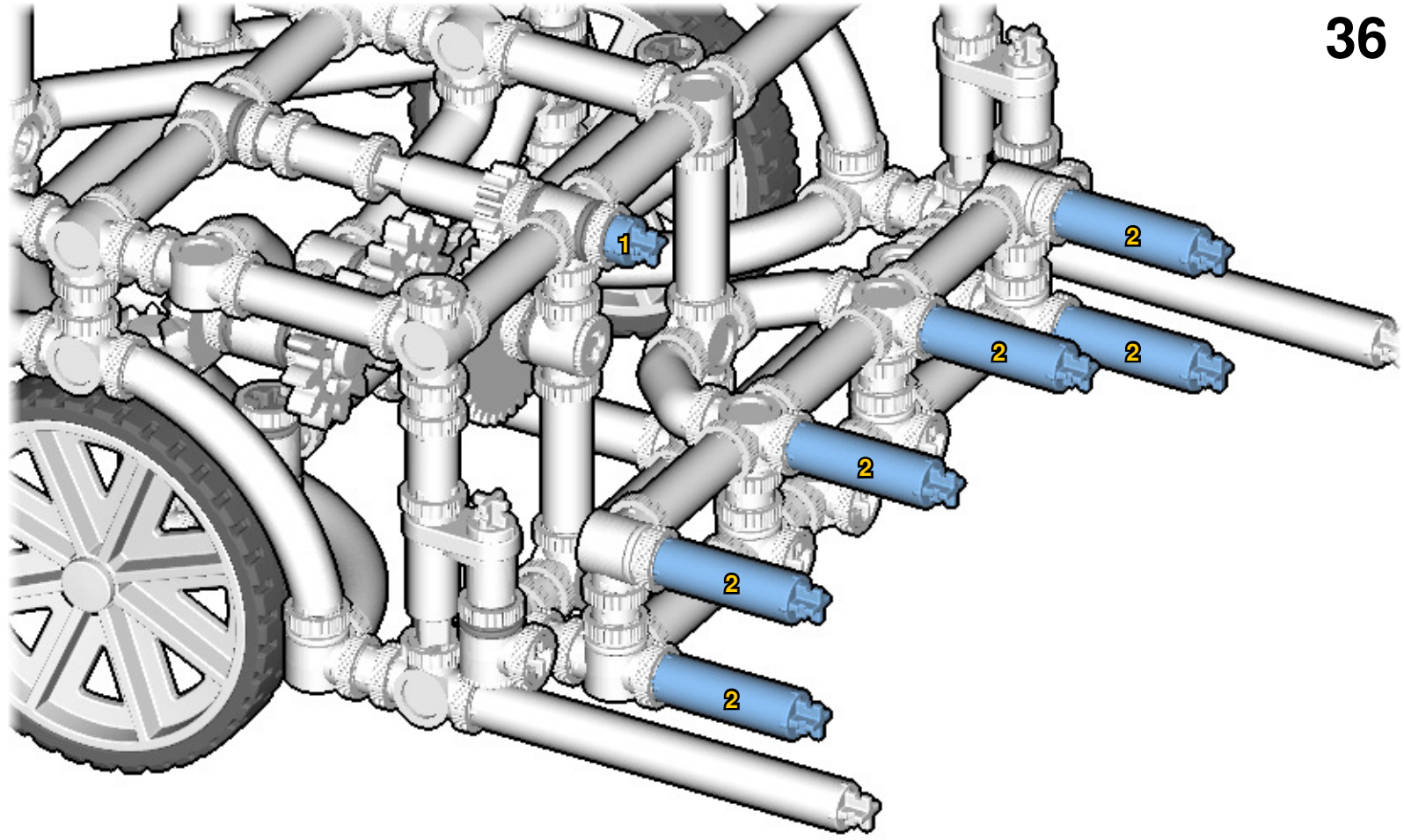

37

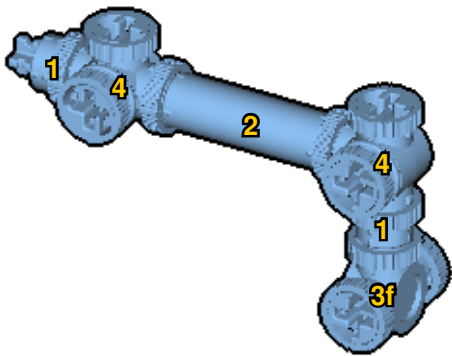

38

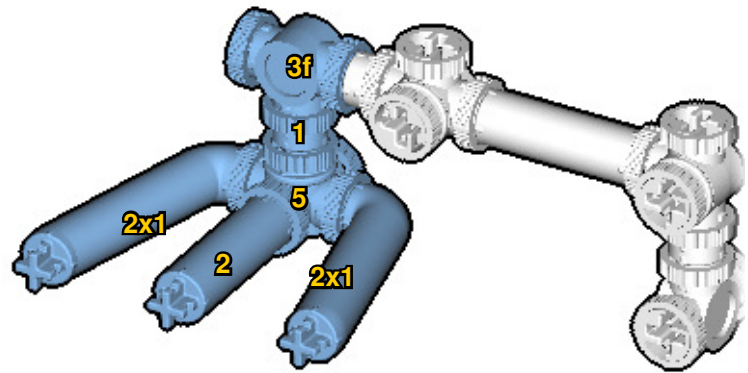

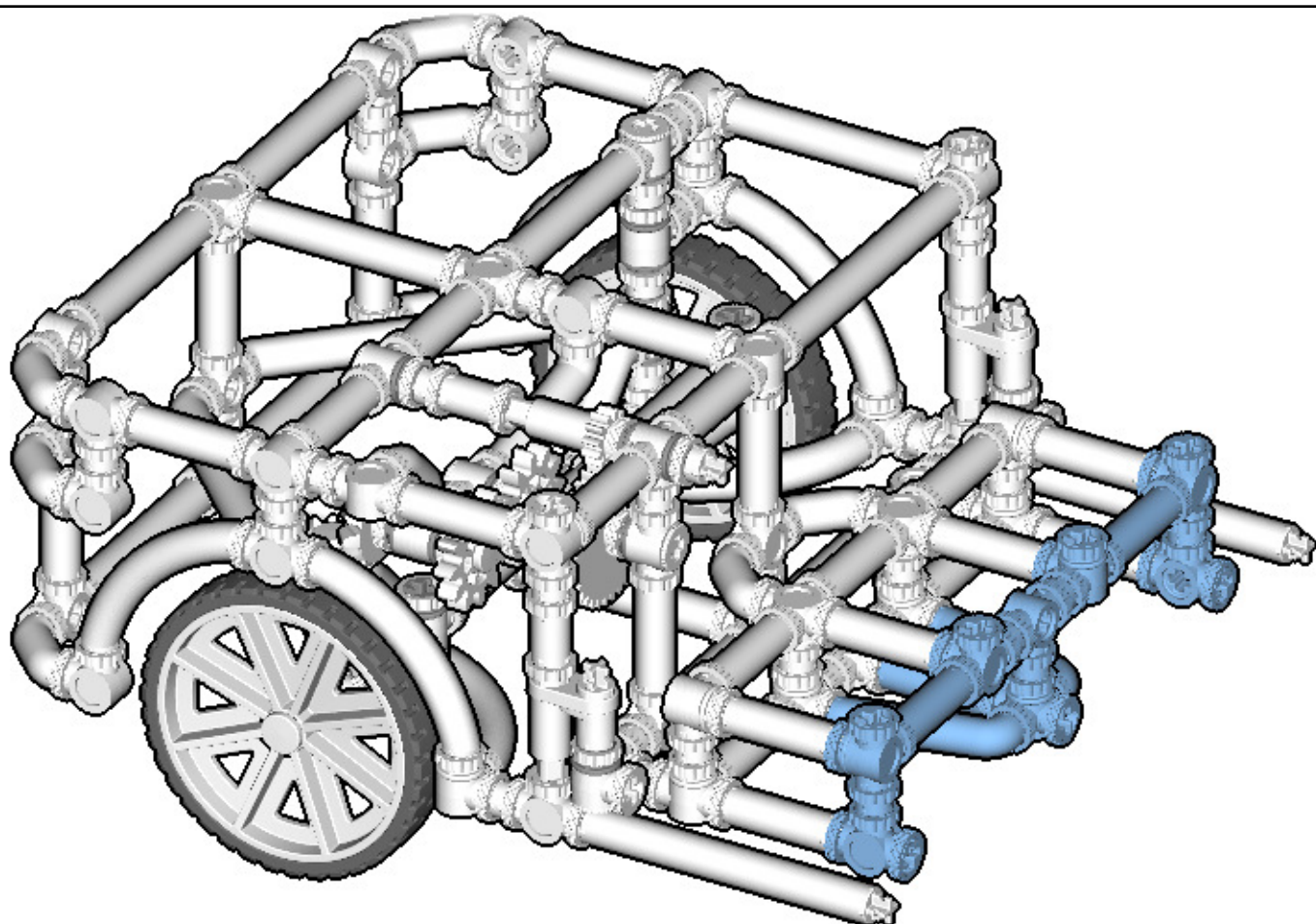
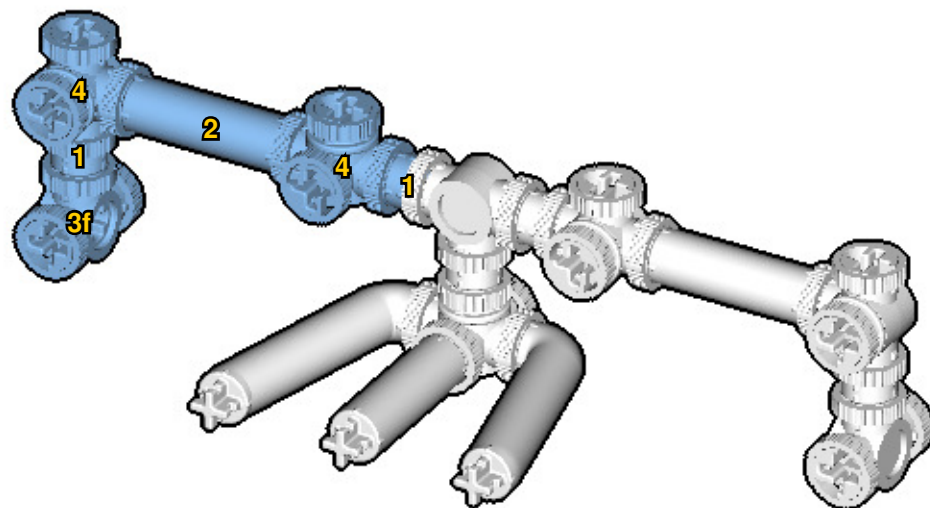

41

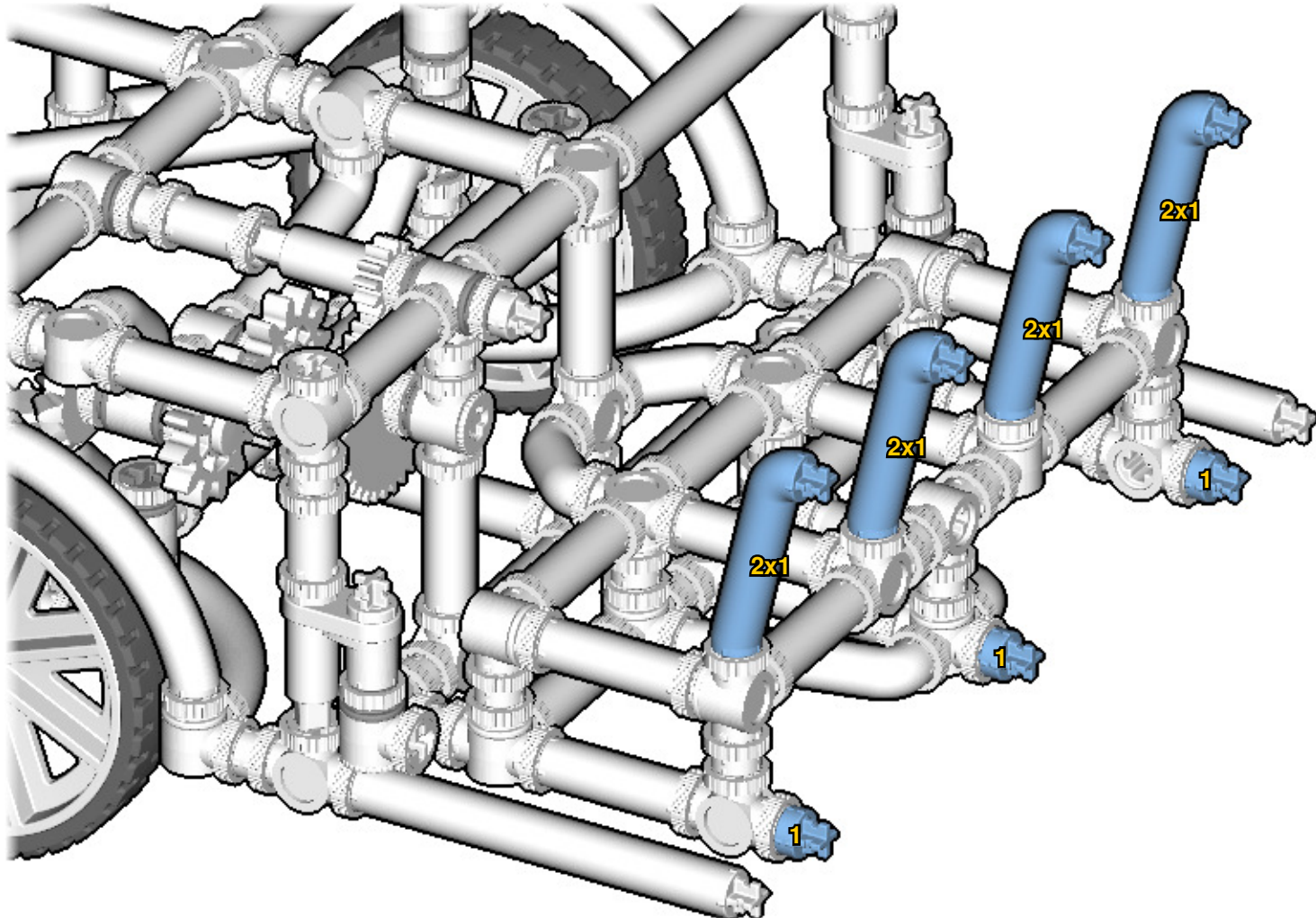

42

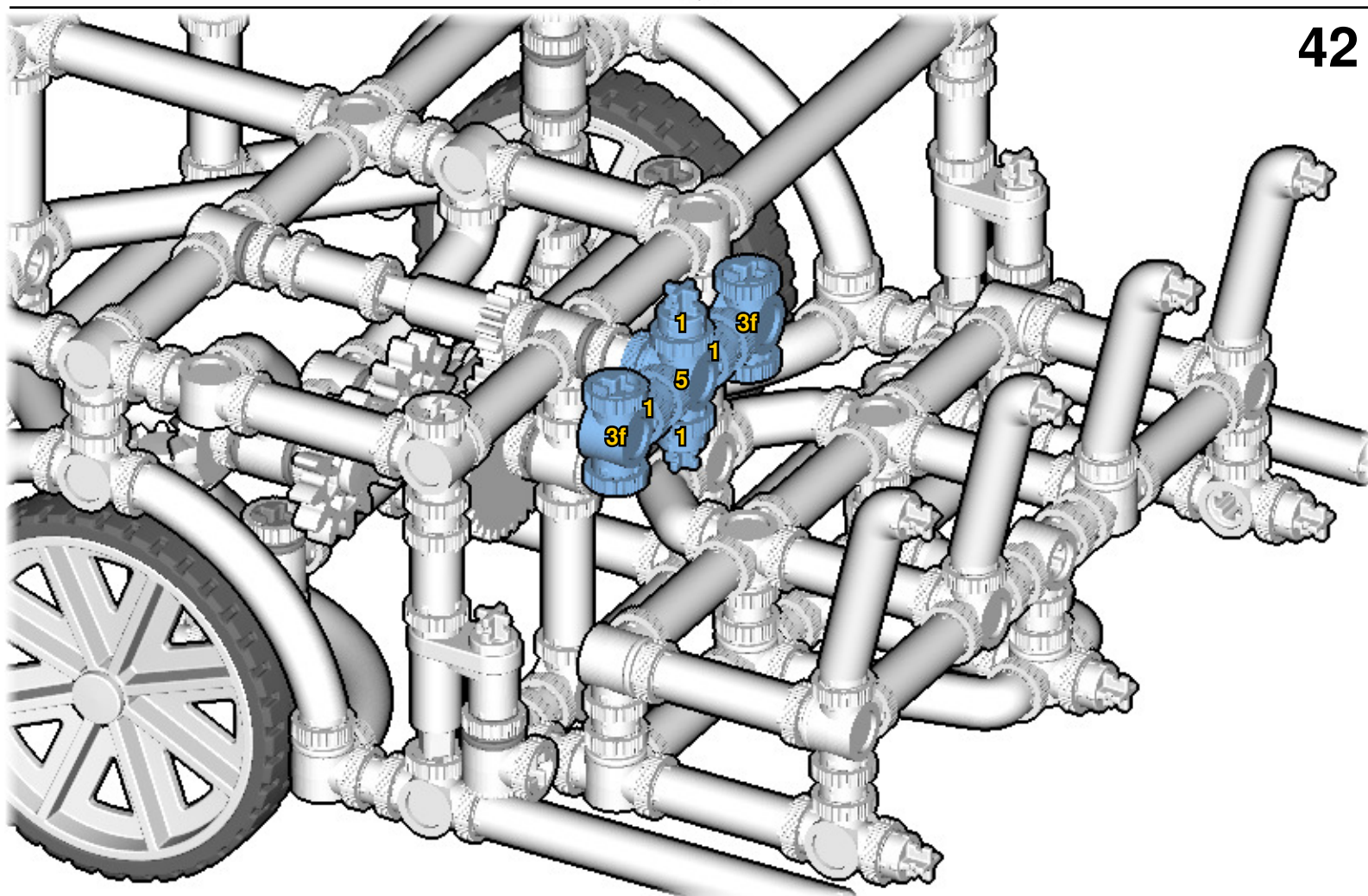

43

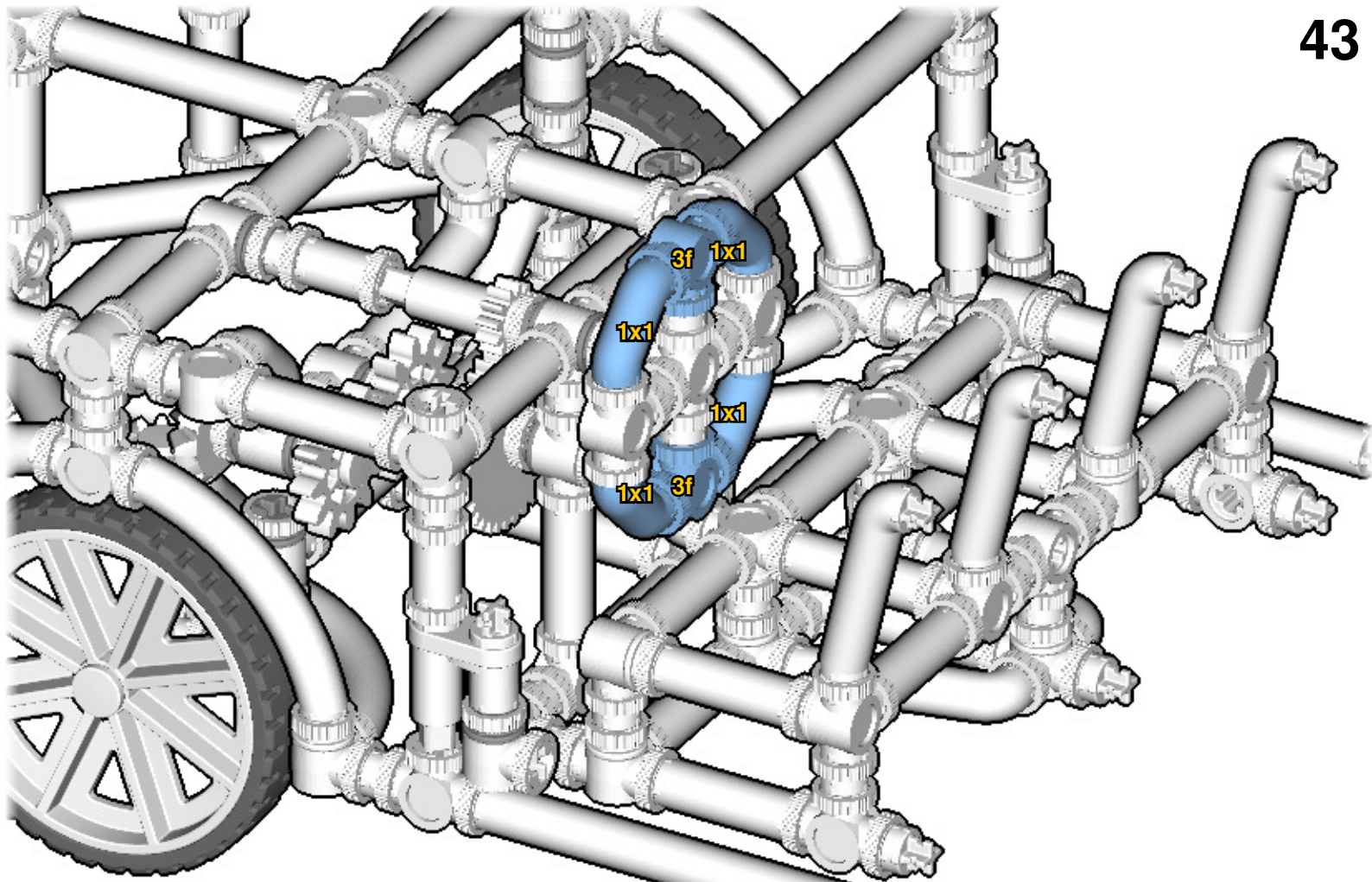

44

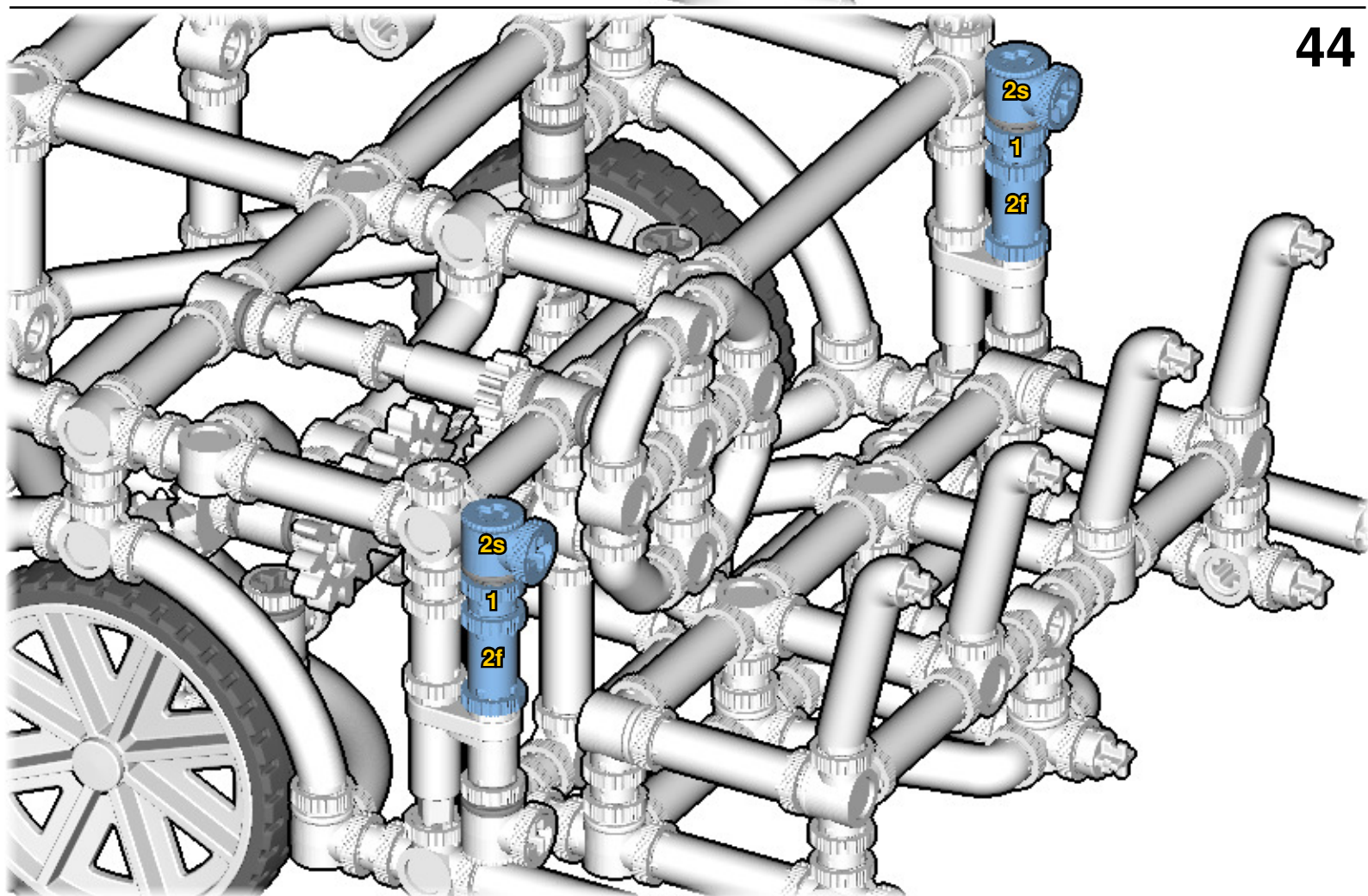

45

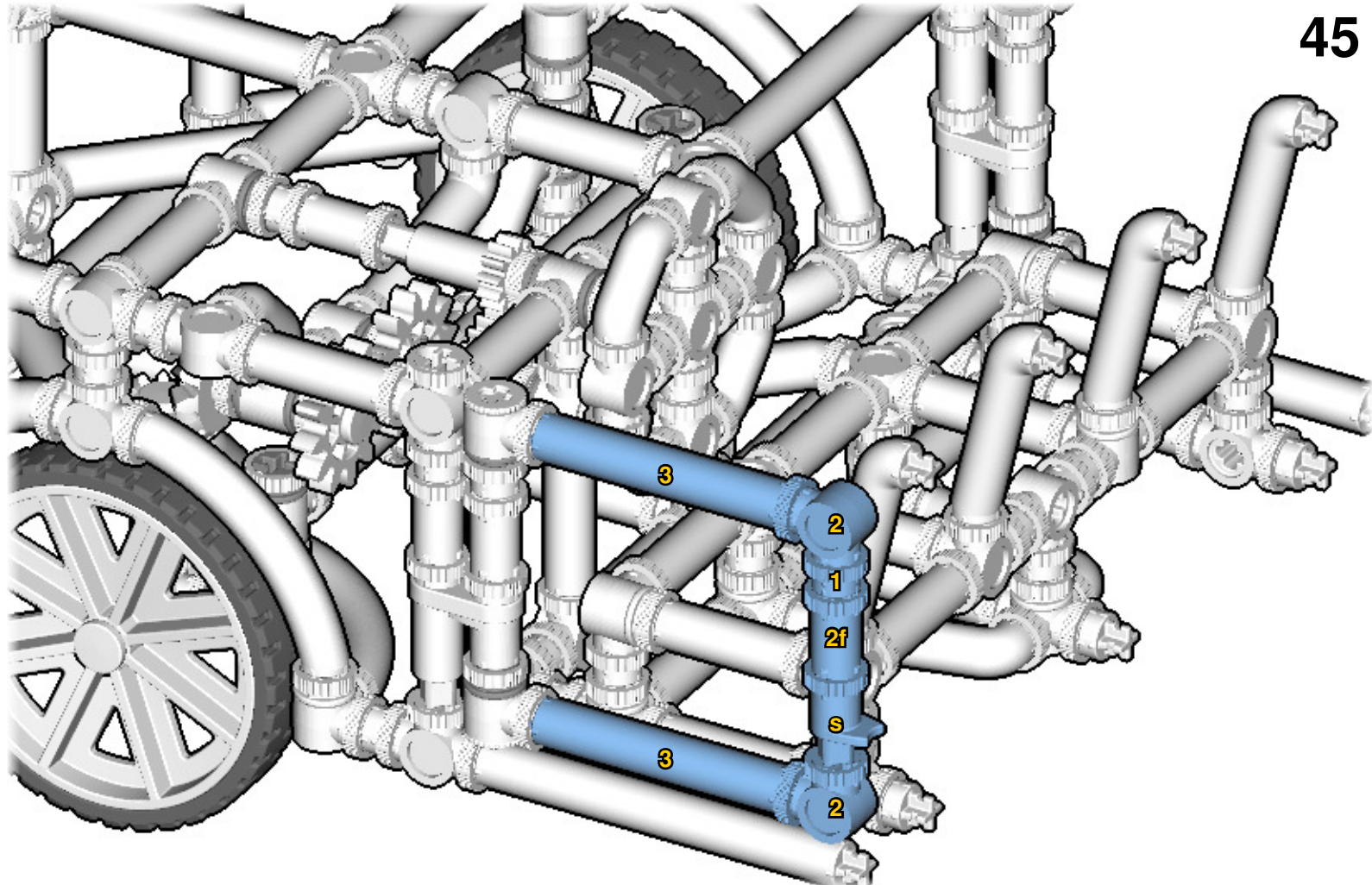

46

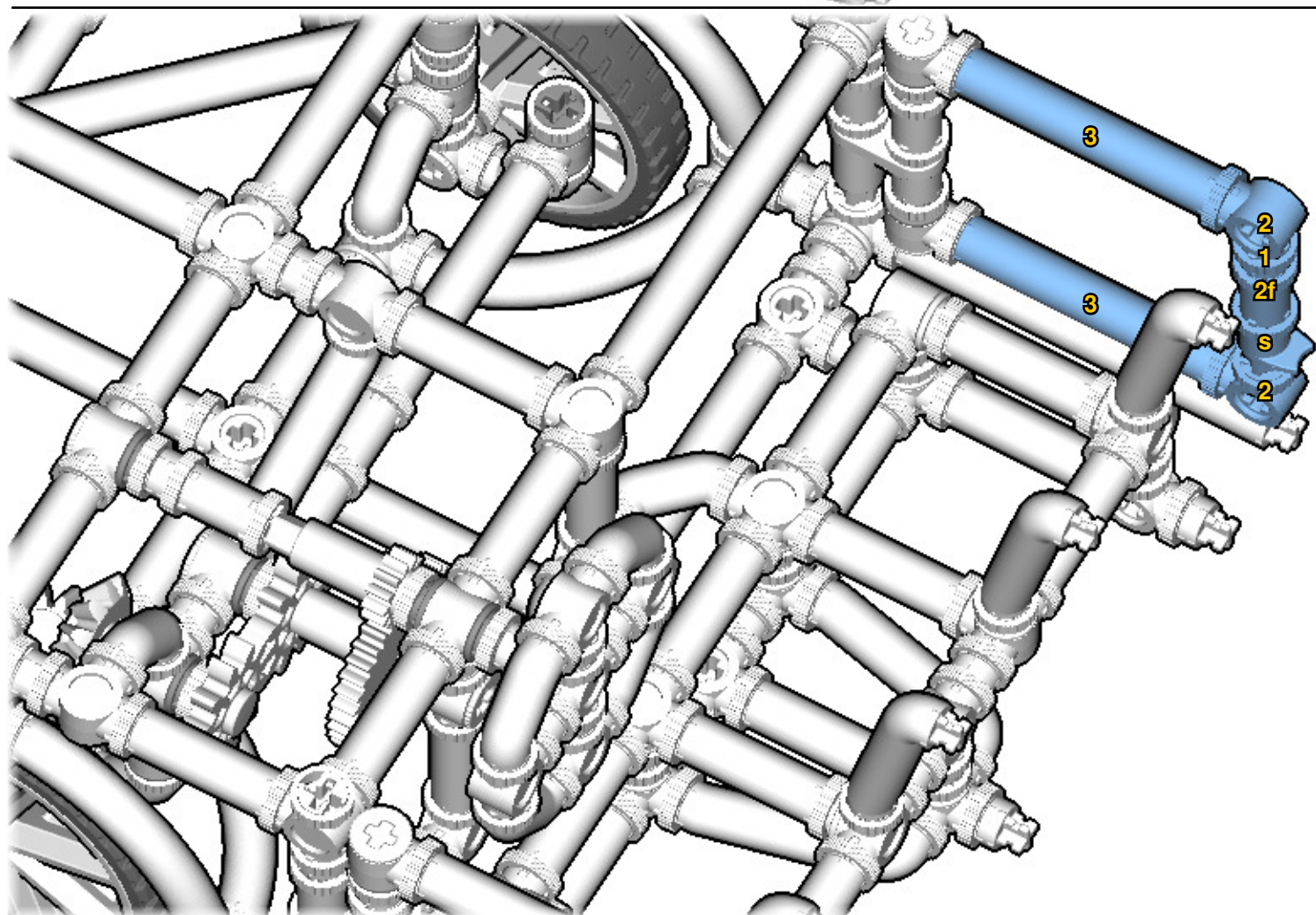

47

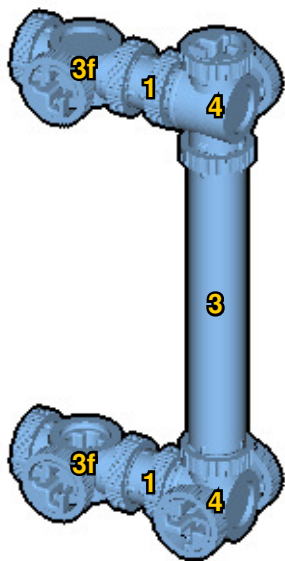

48

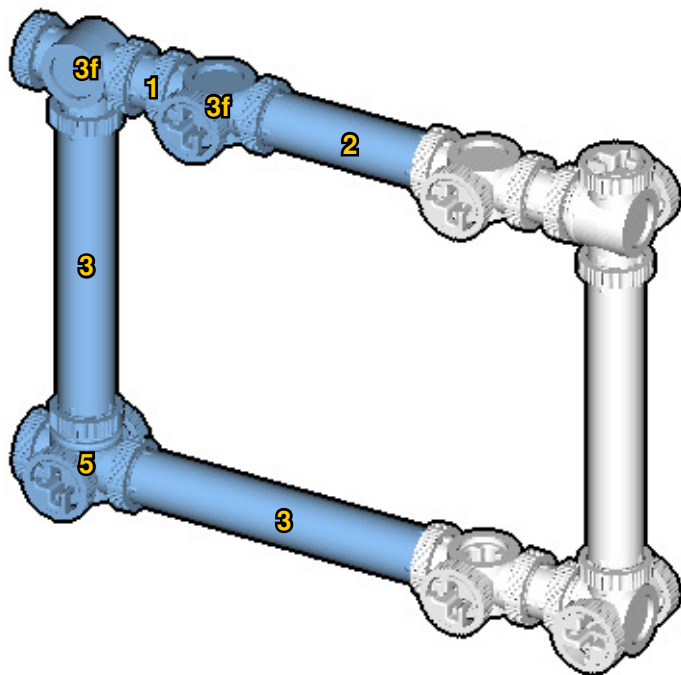

49

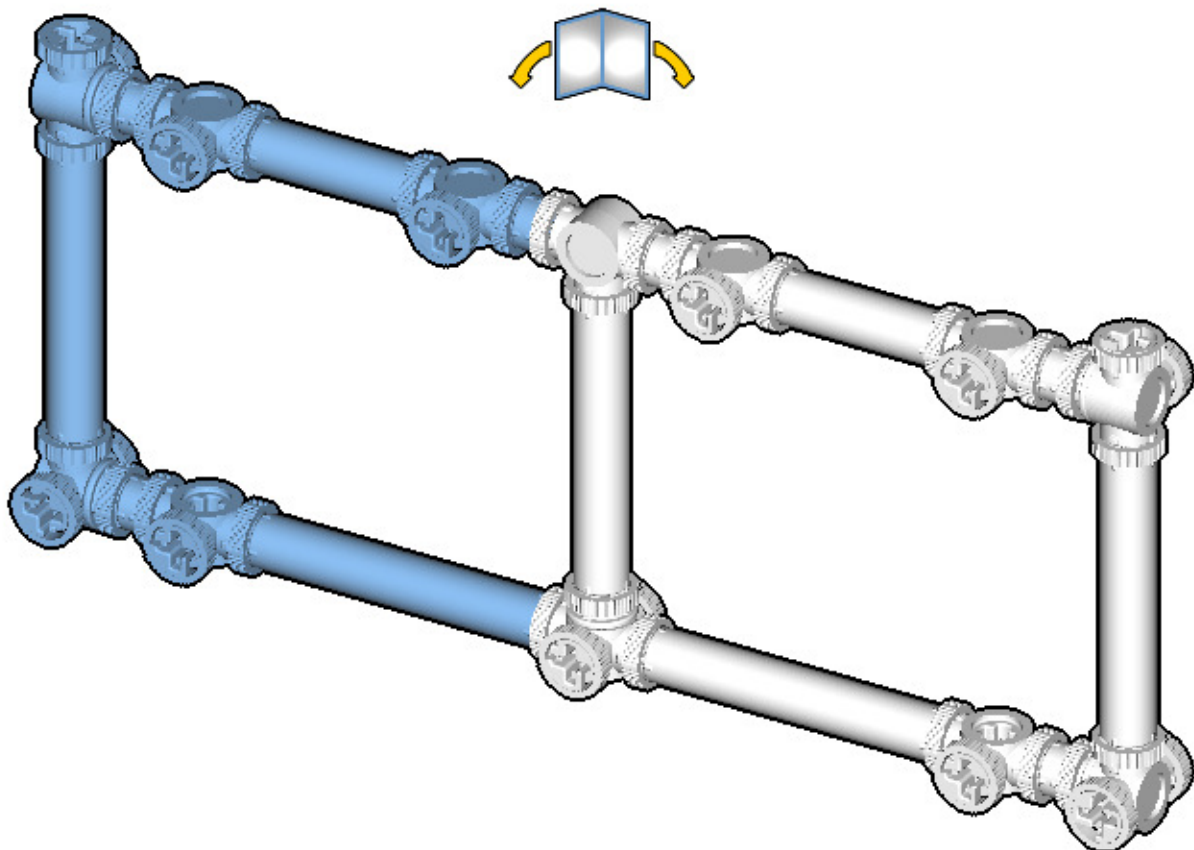

50

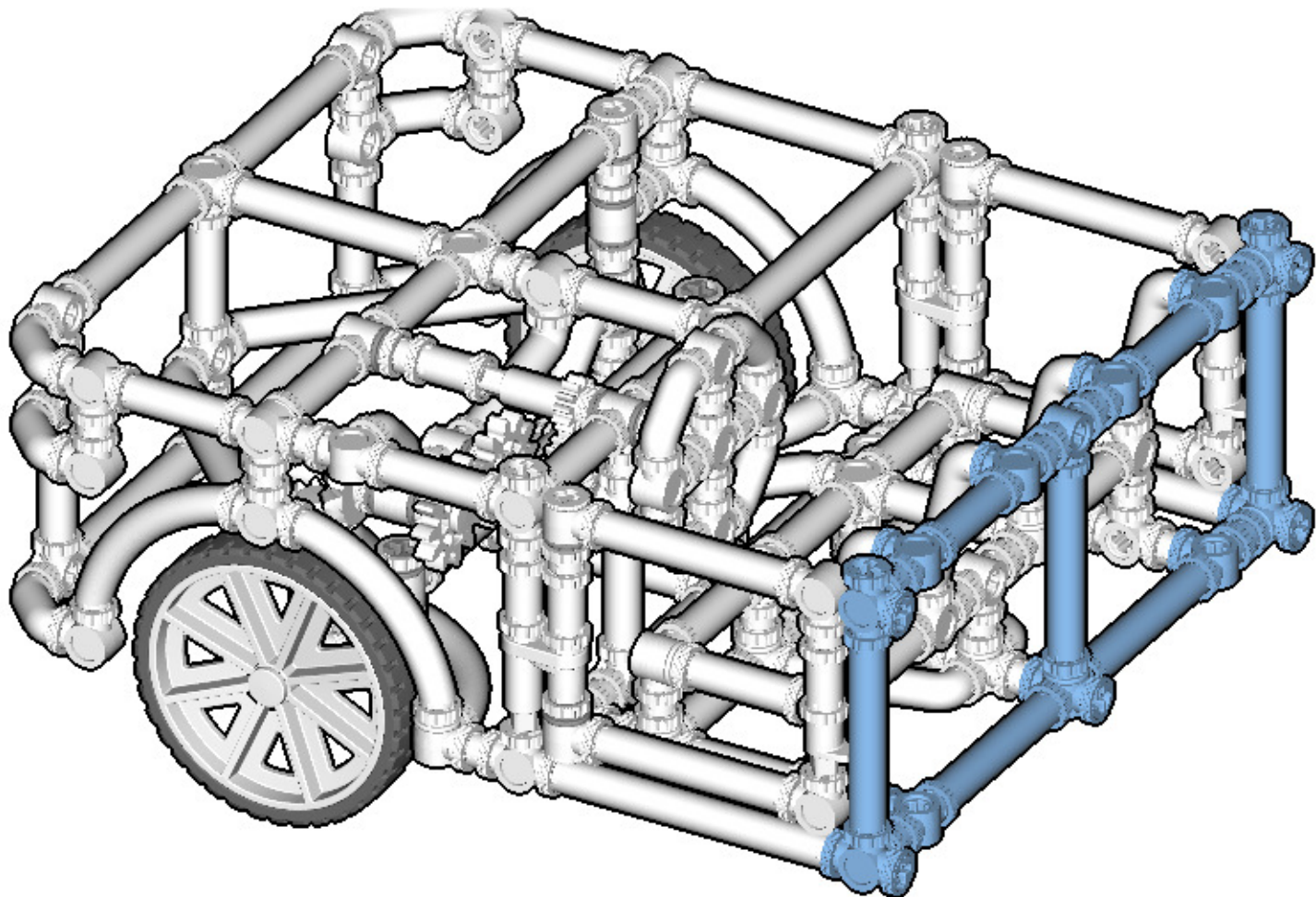

51

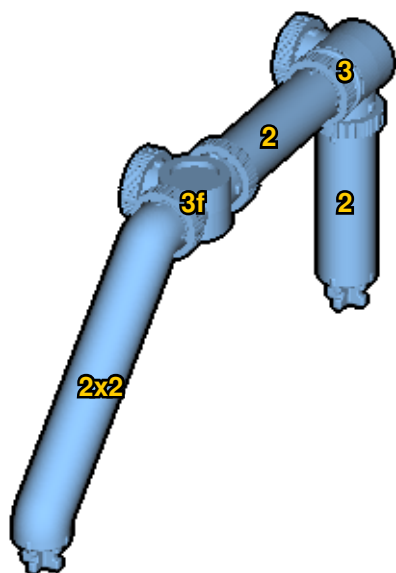

52

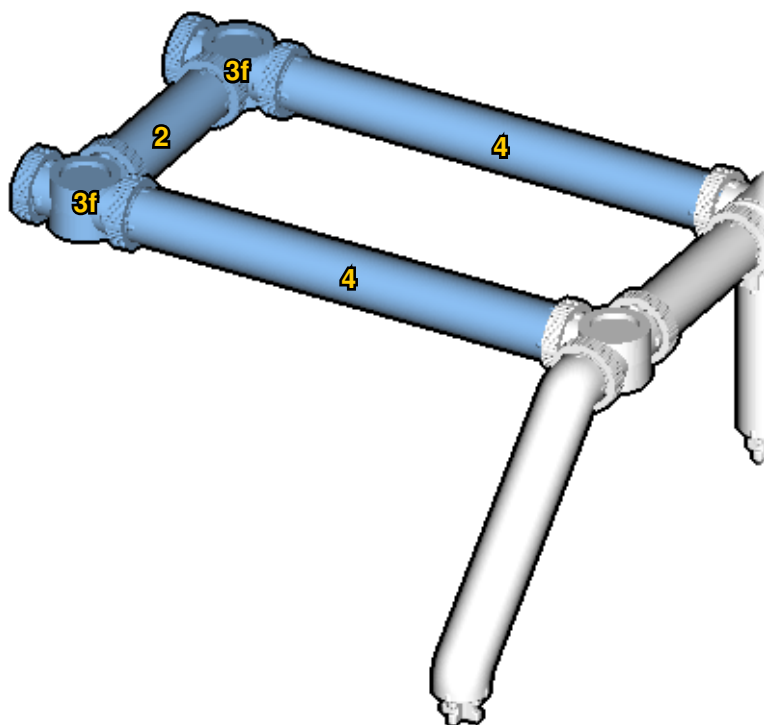

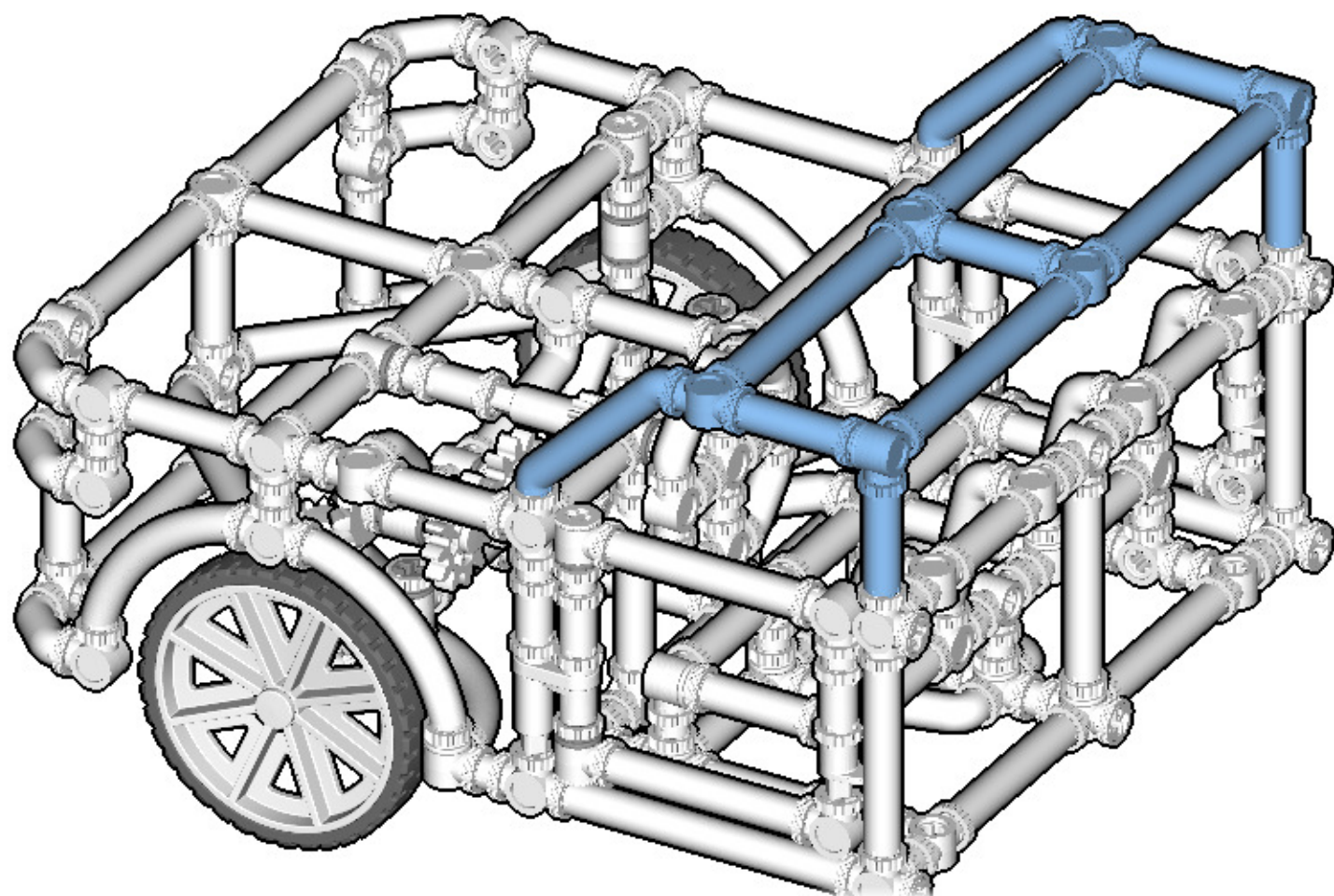
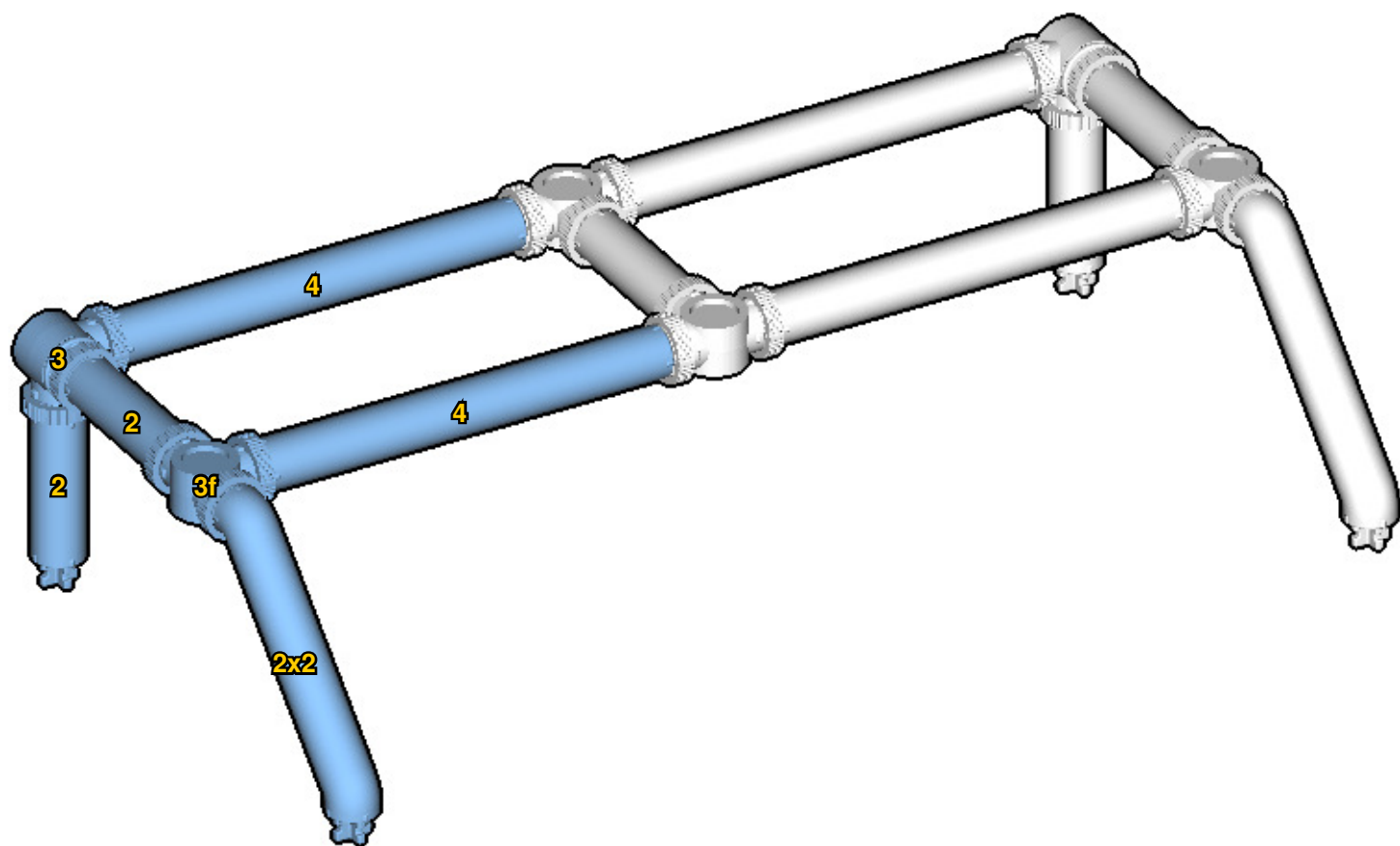

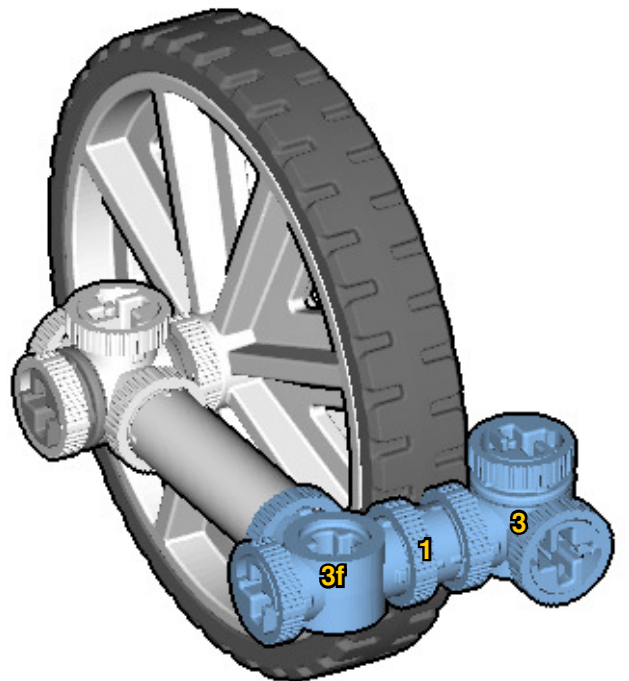
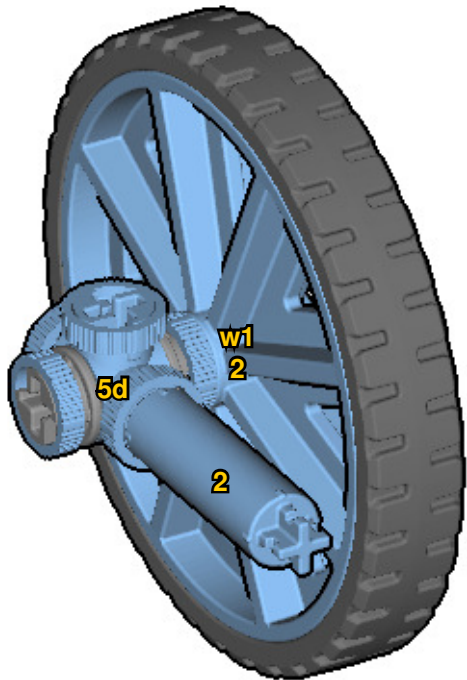
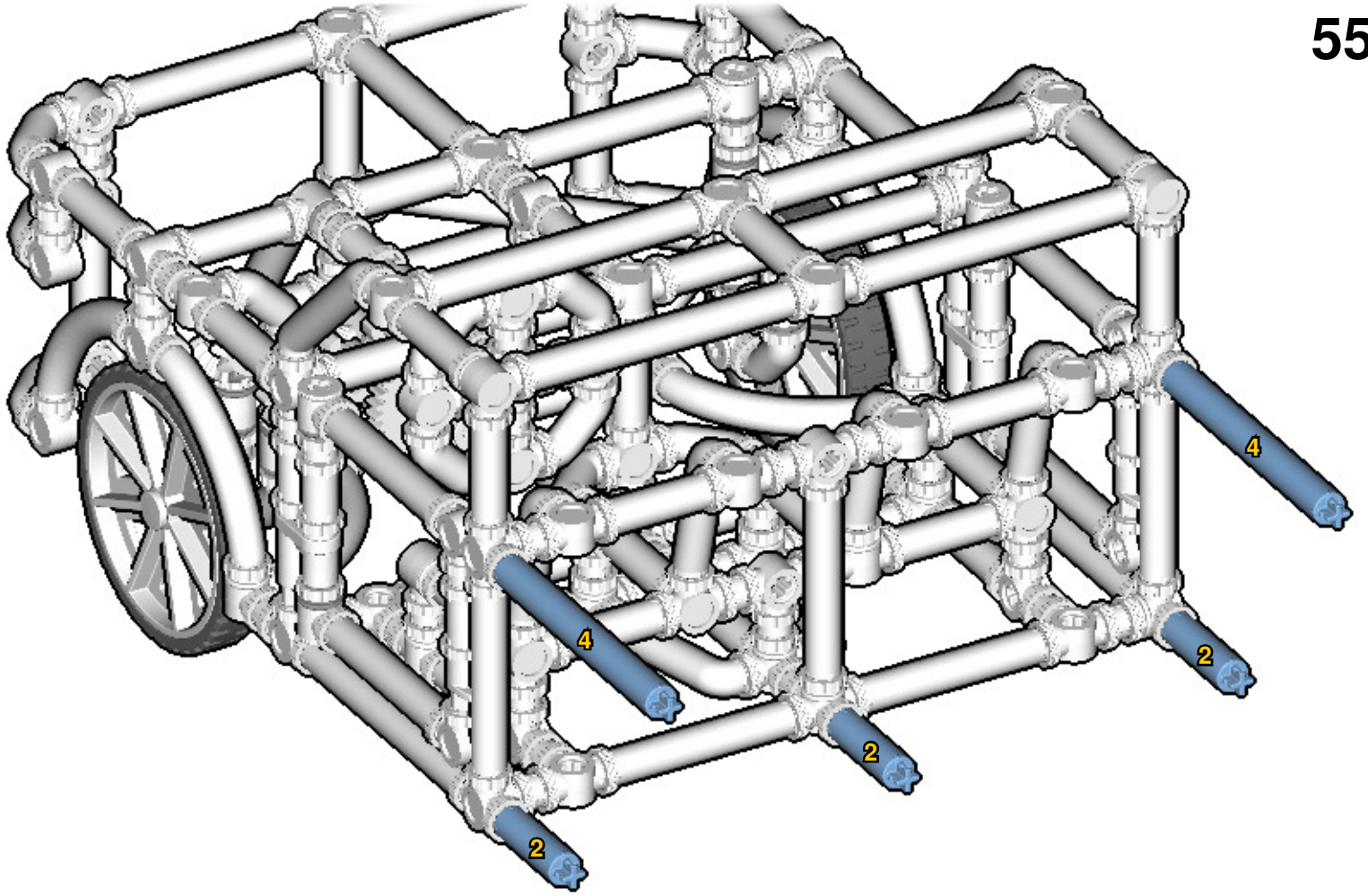

58

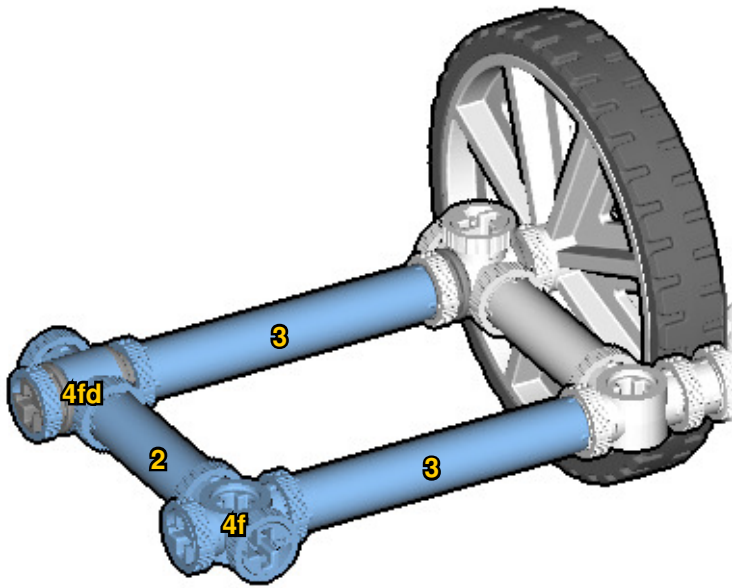

59

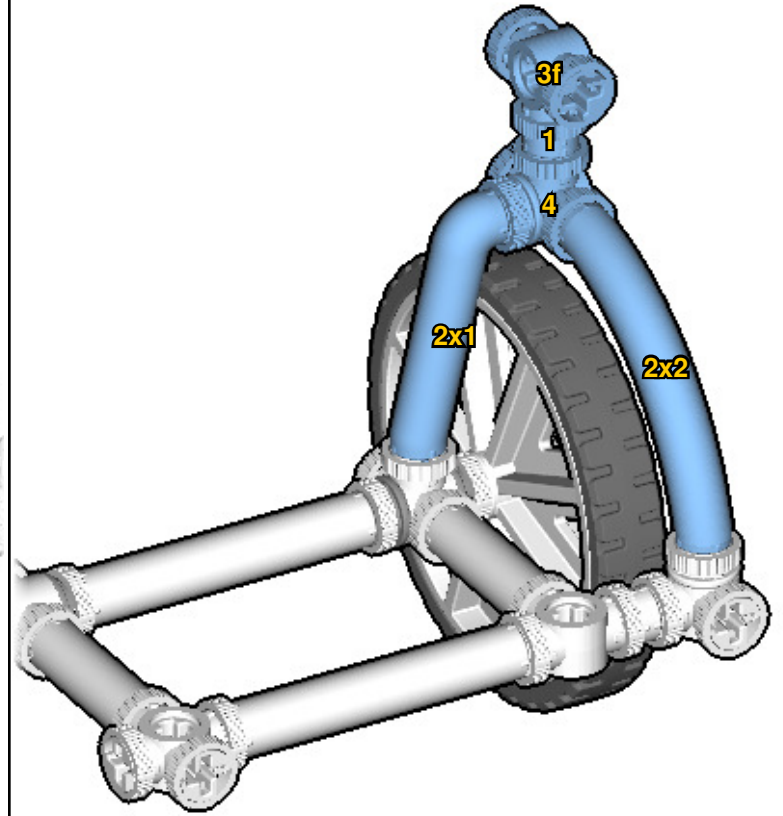

60

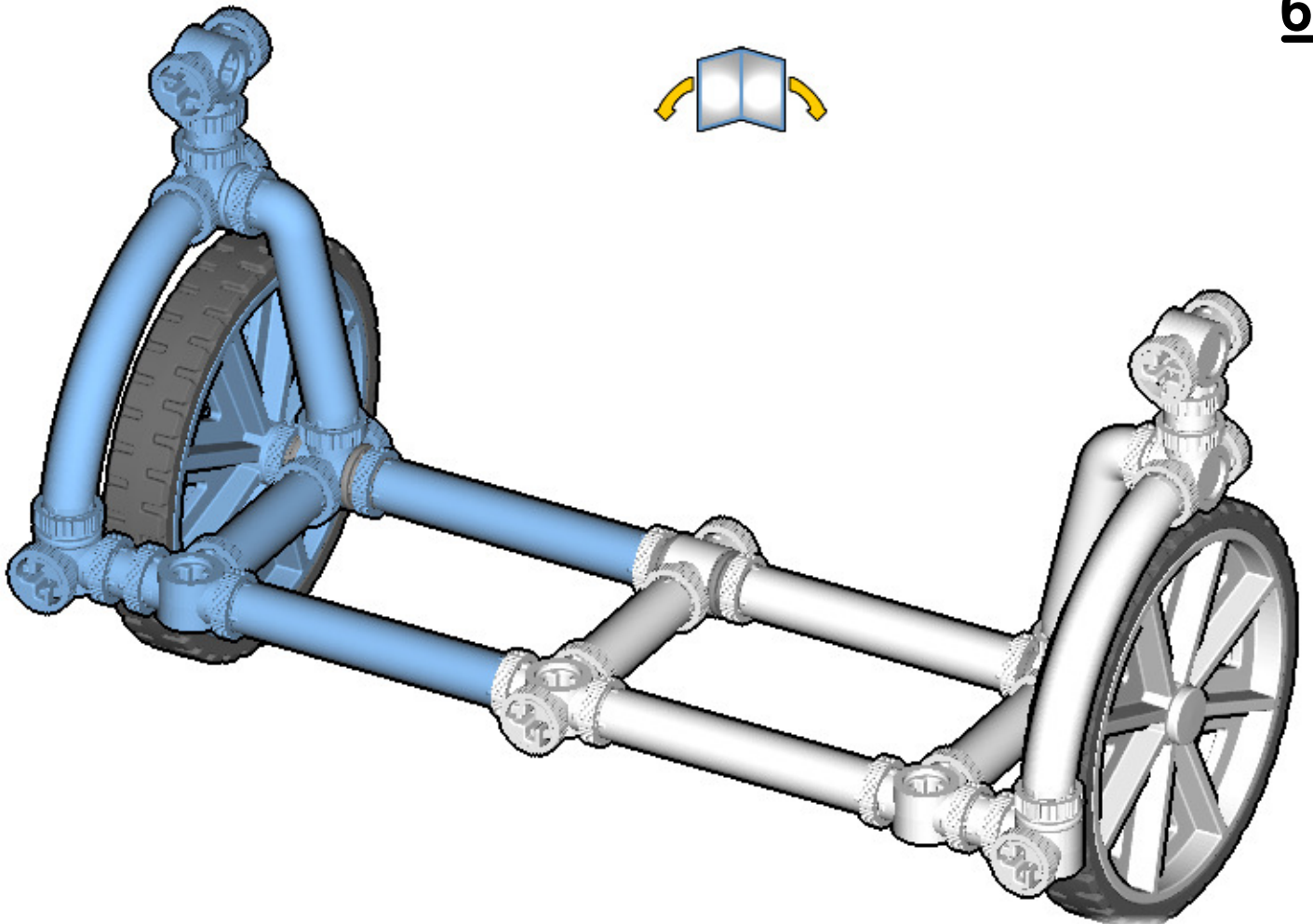

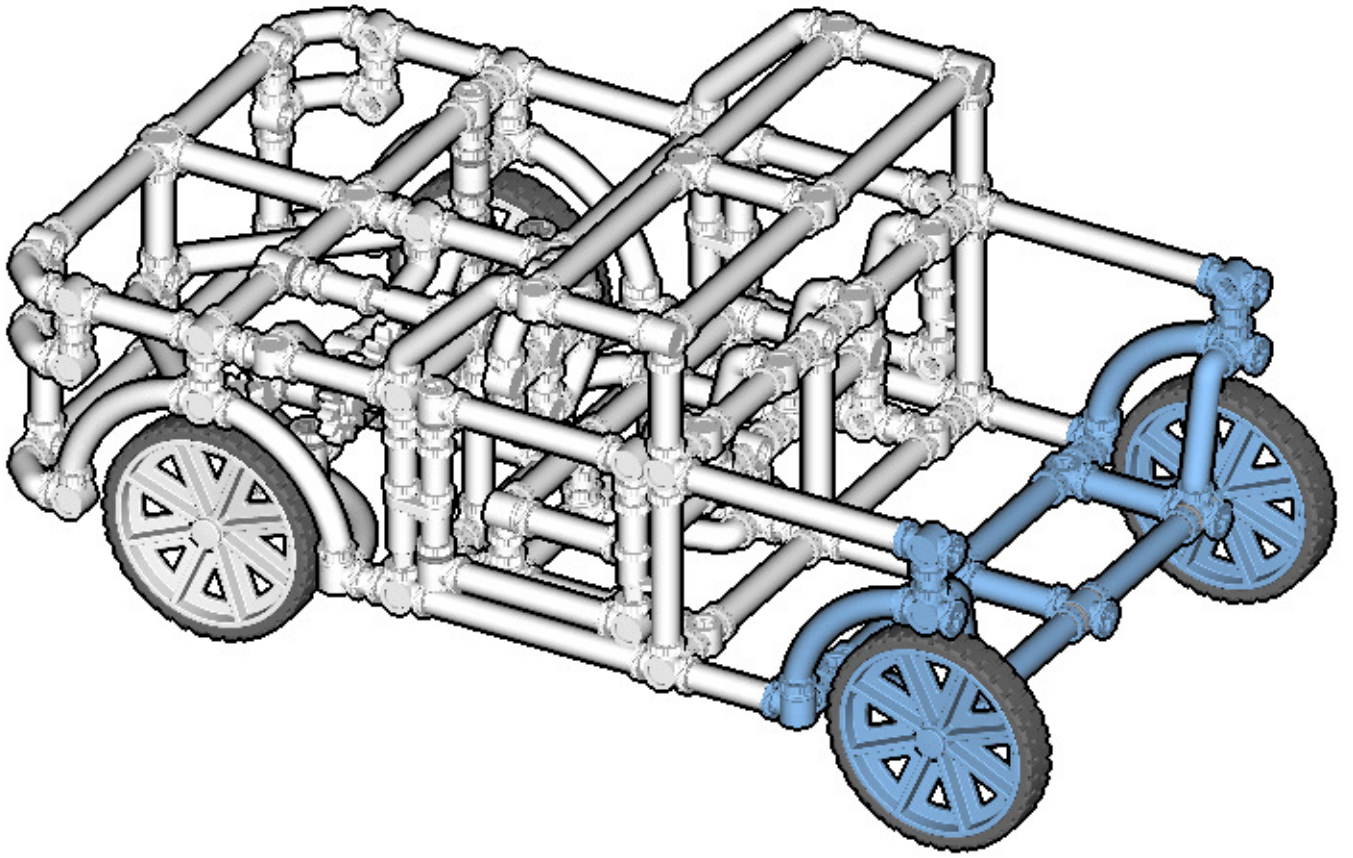
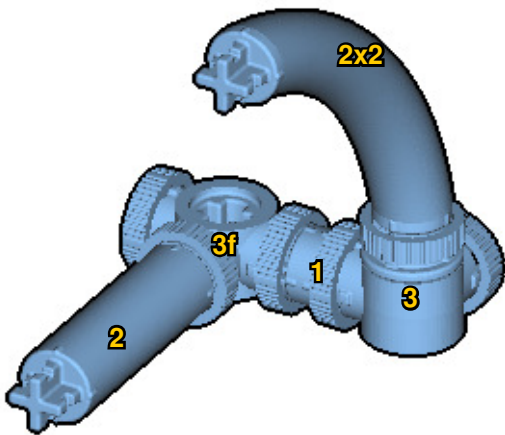
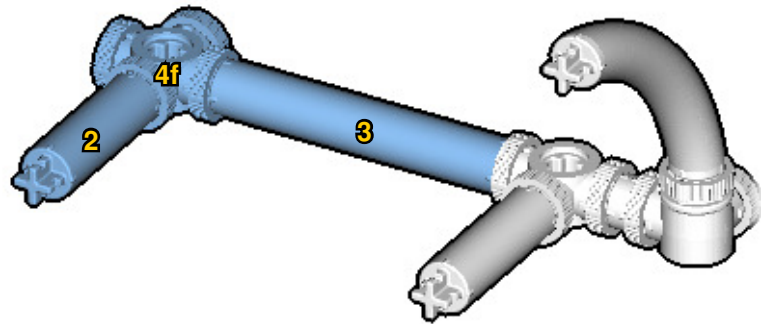
6263

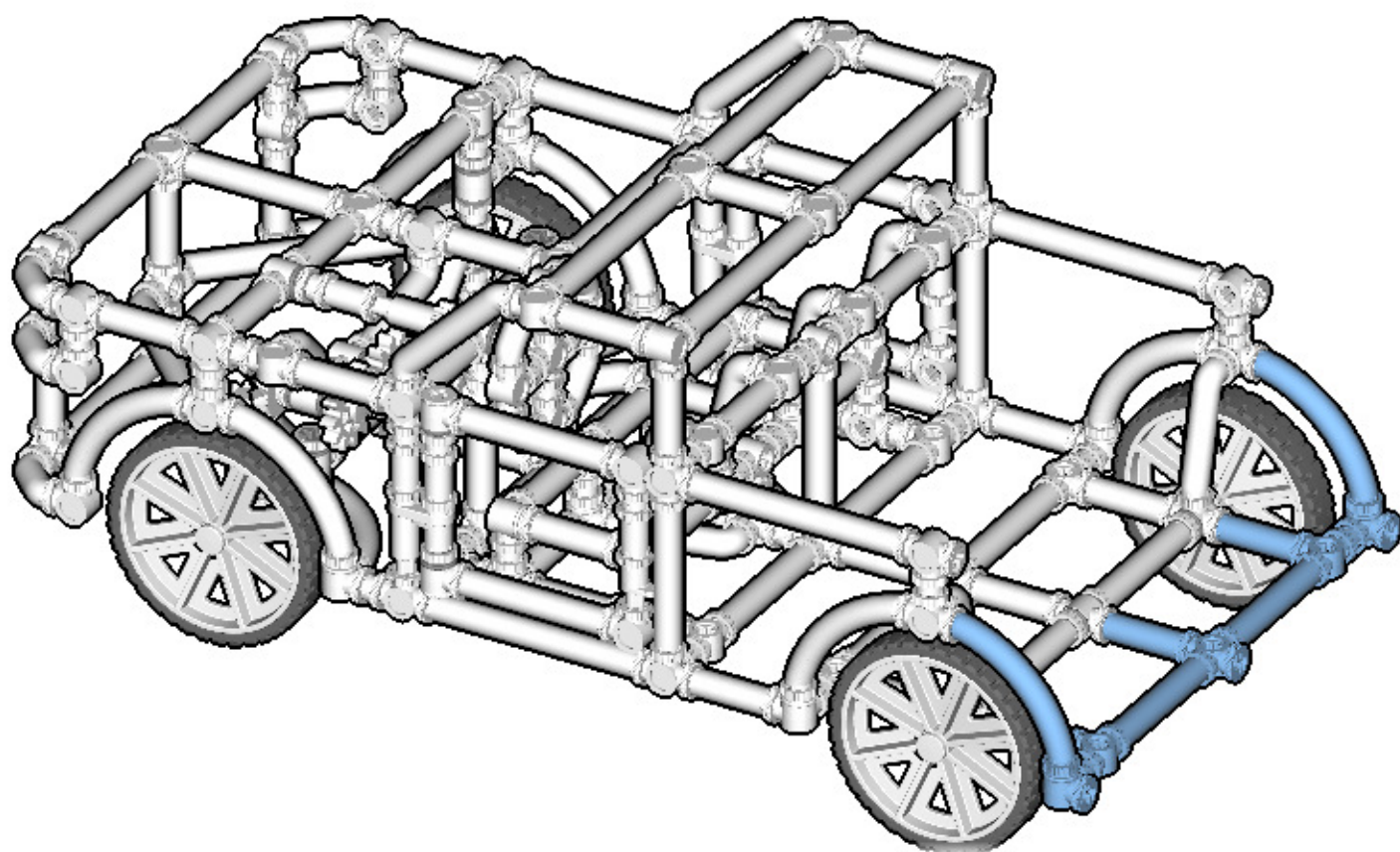
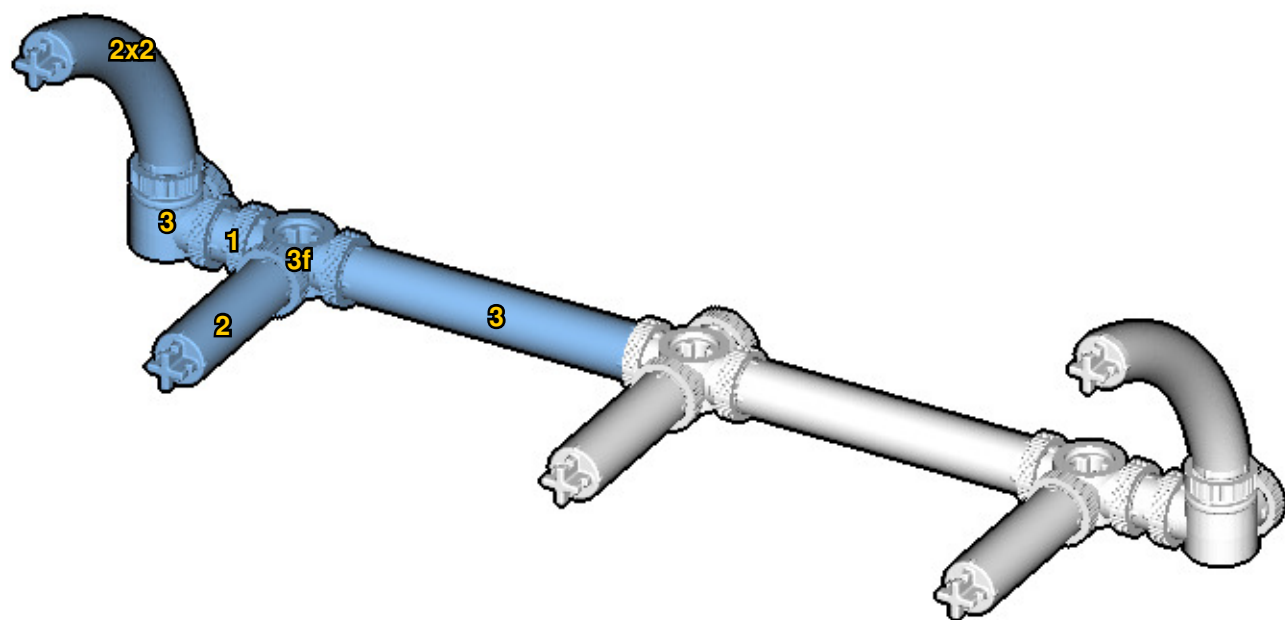

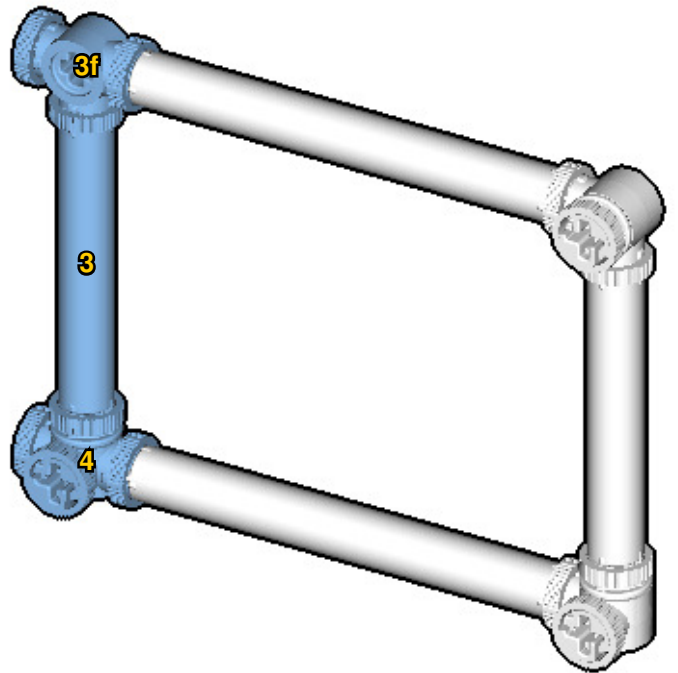
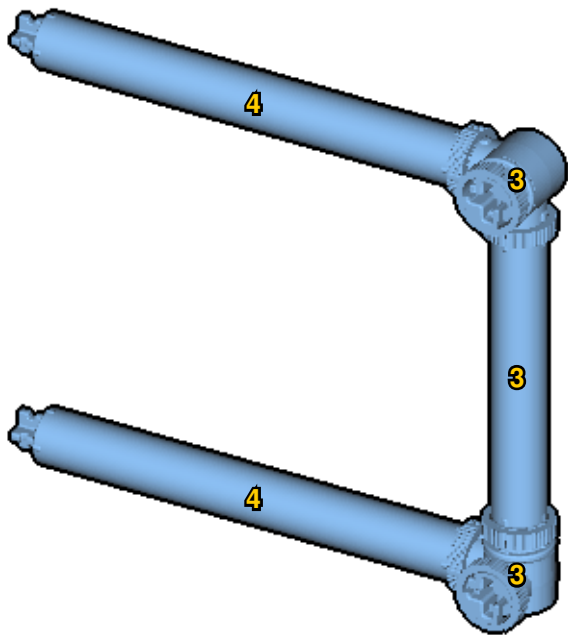
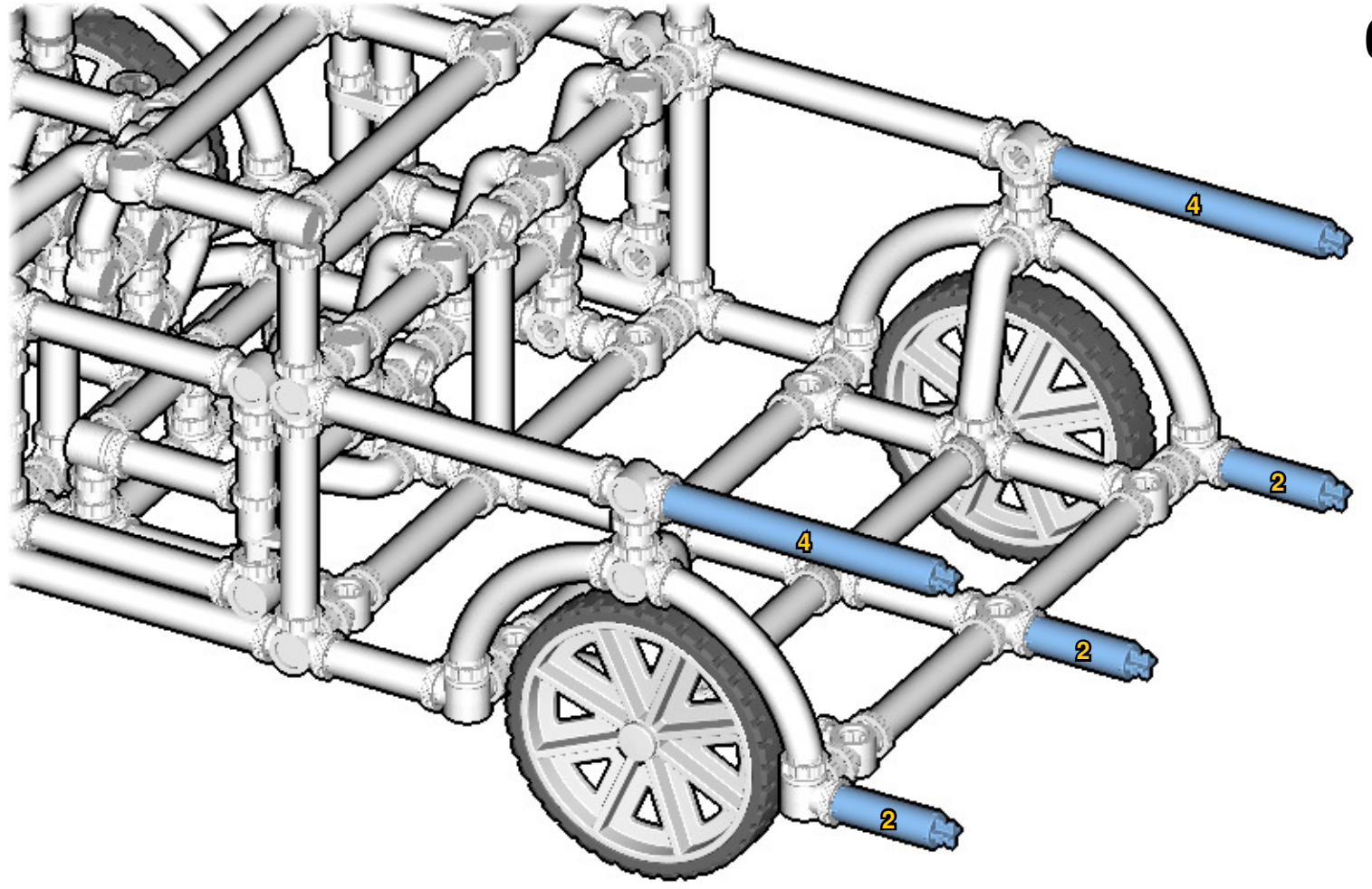

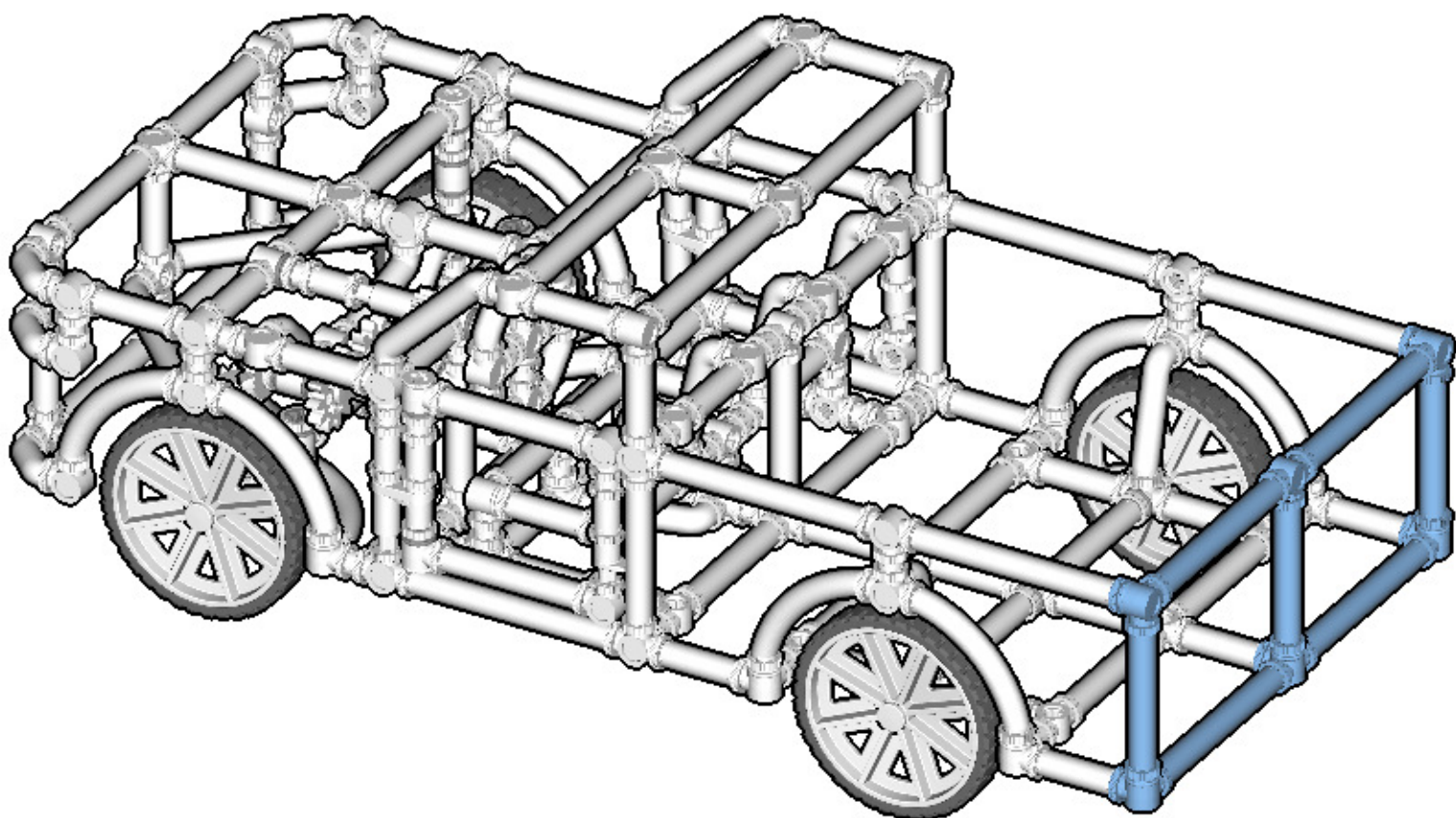
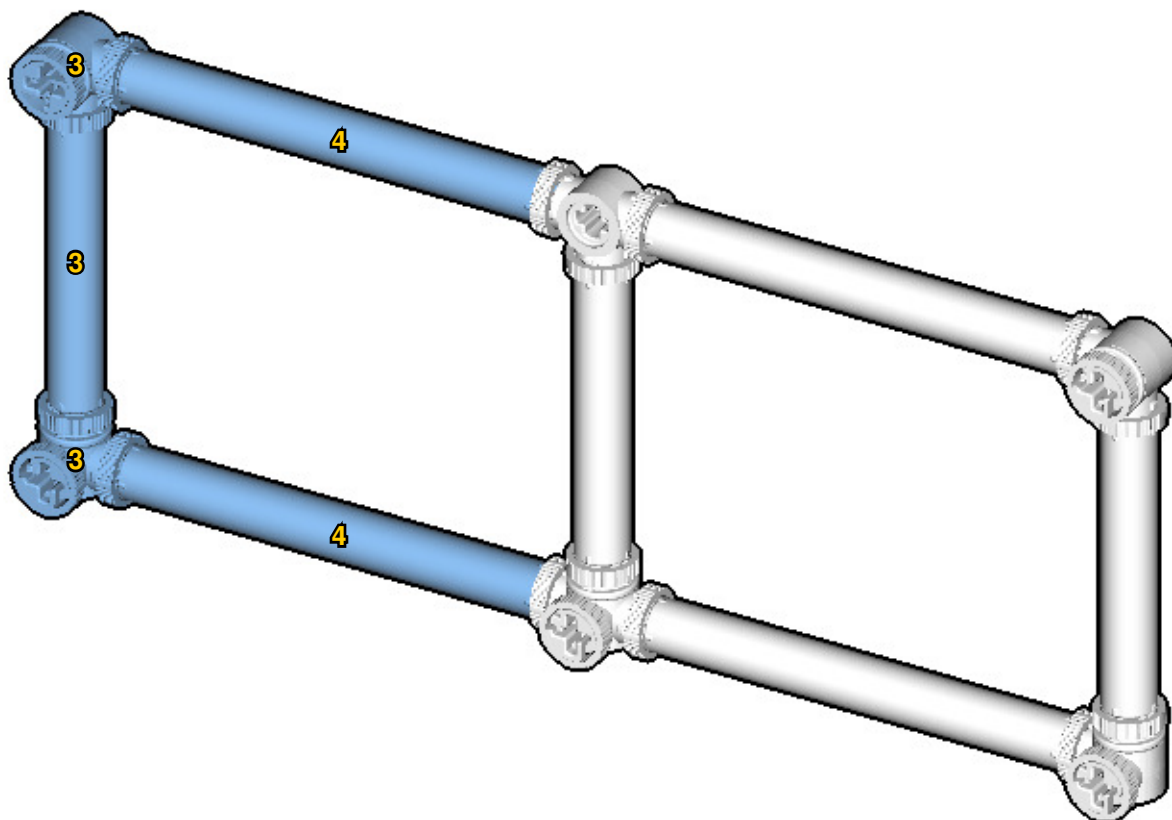

INVENTORY

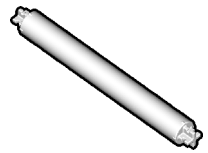
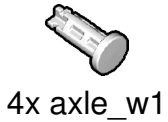
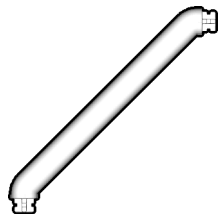
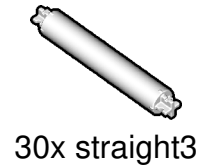
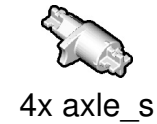
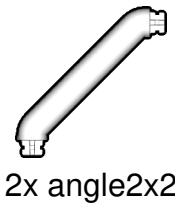
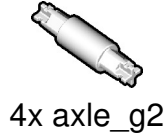

ACTUAL SIZE

