

CROSS BEAMS™

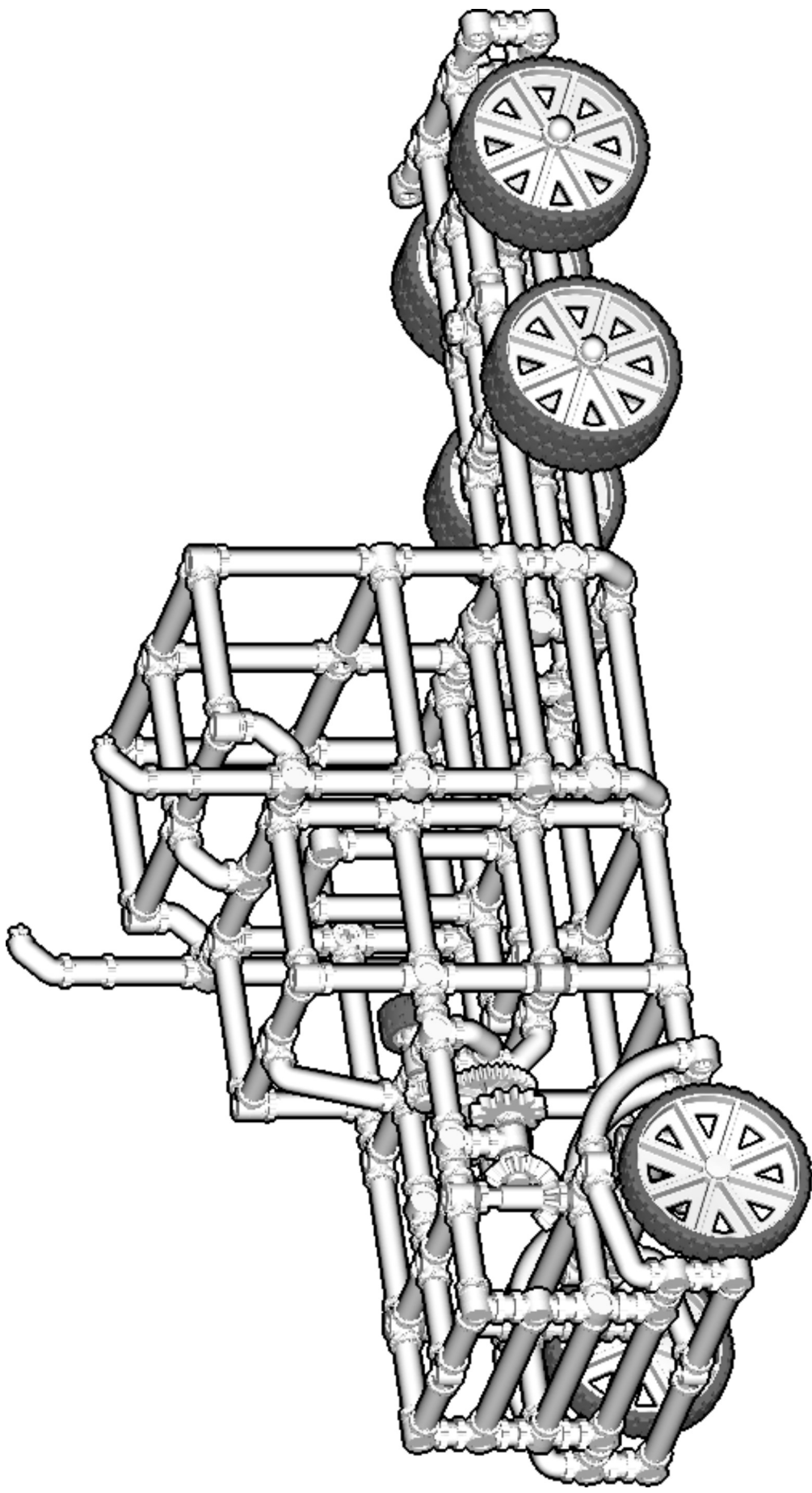

SEMI

SIZE

1.7ft x 0.7ft x 0.4ft

PIECES

352

DESIGNER

Derek Sharman

MADE IN

U.S.A.



Wrong
Connecting/Disconnecting Two Directions



Right
Connecting/Disconnecting One Direction

1

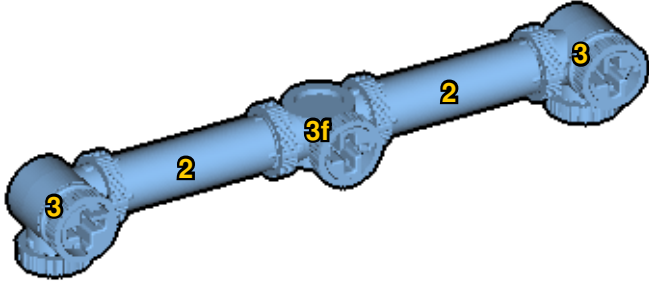

New pieces are drawn blue. Old pieces are drawn white.
See back for piece names.

2

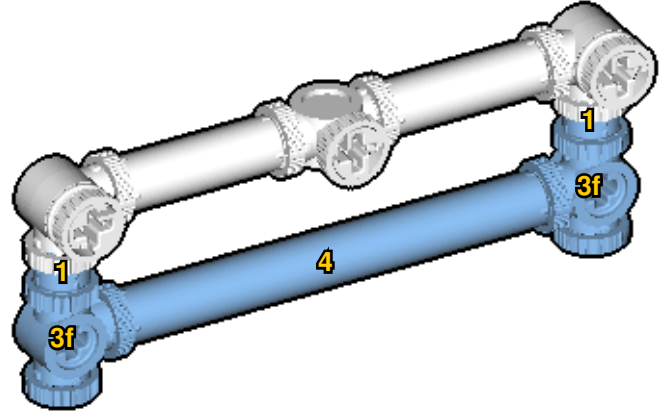

Connect new pieces together before connecting to old pieces.

3

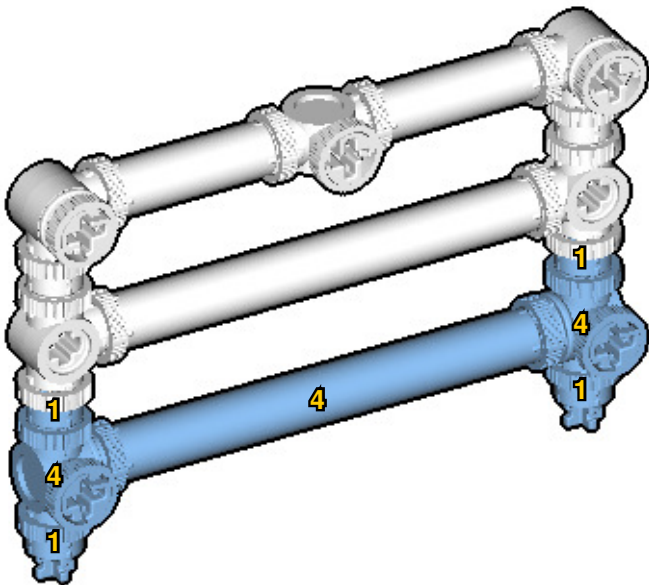

4

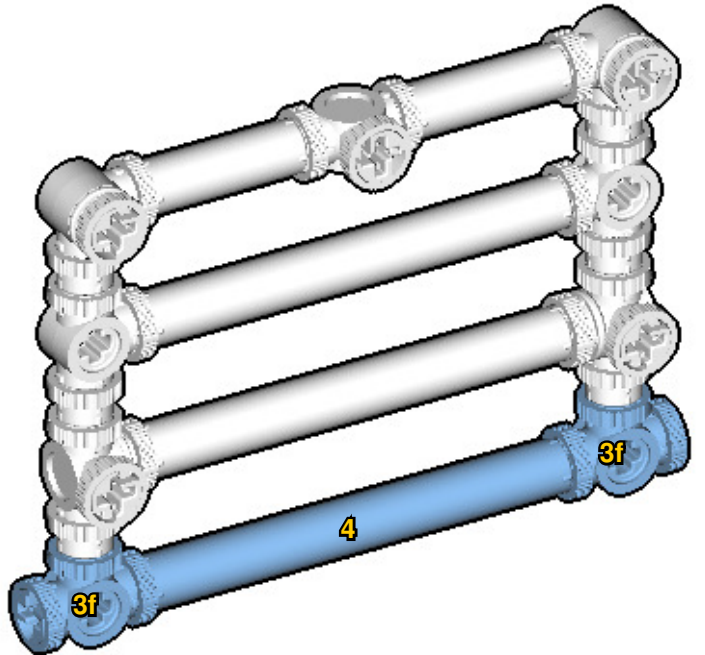

5

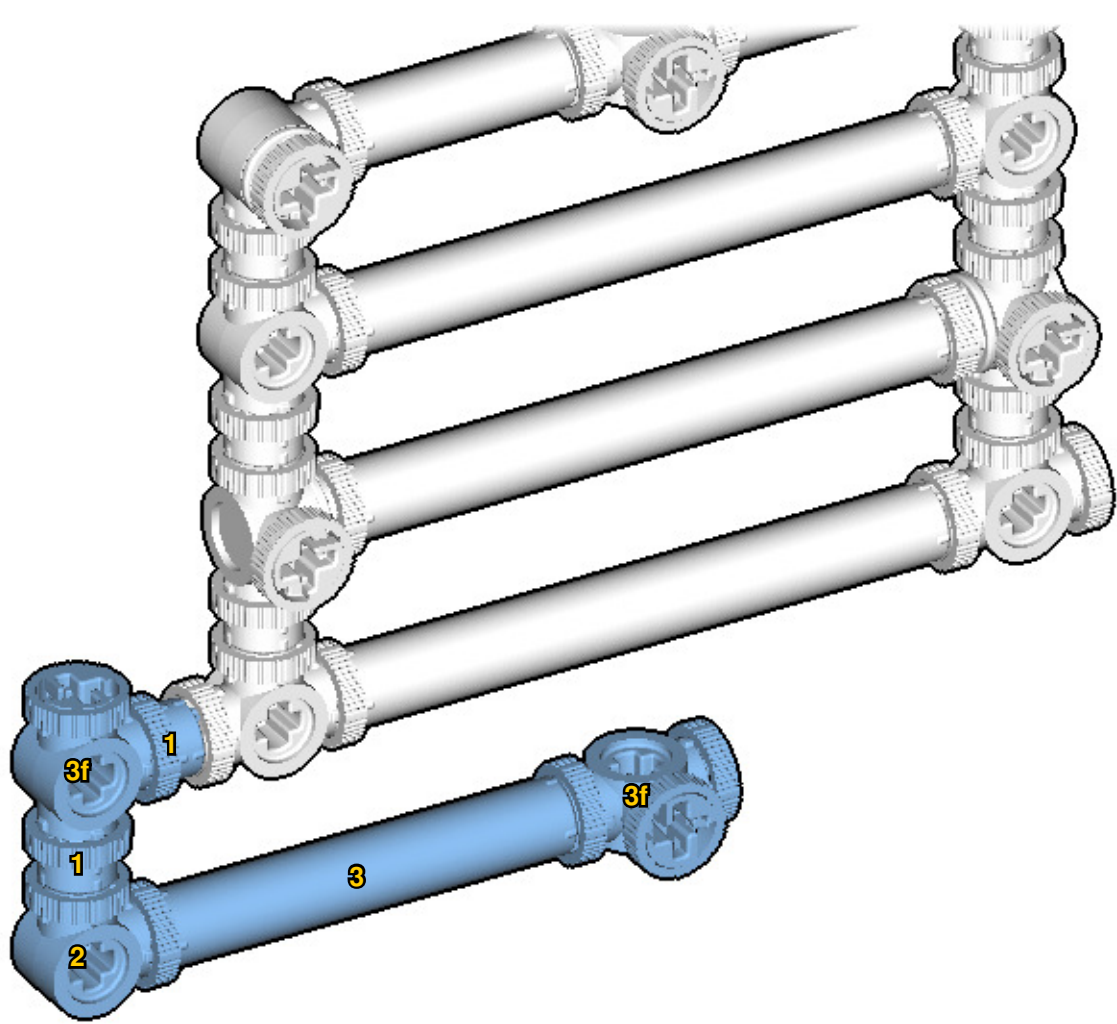

6

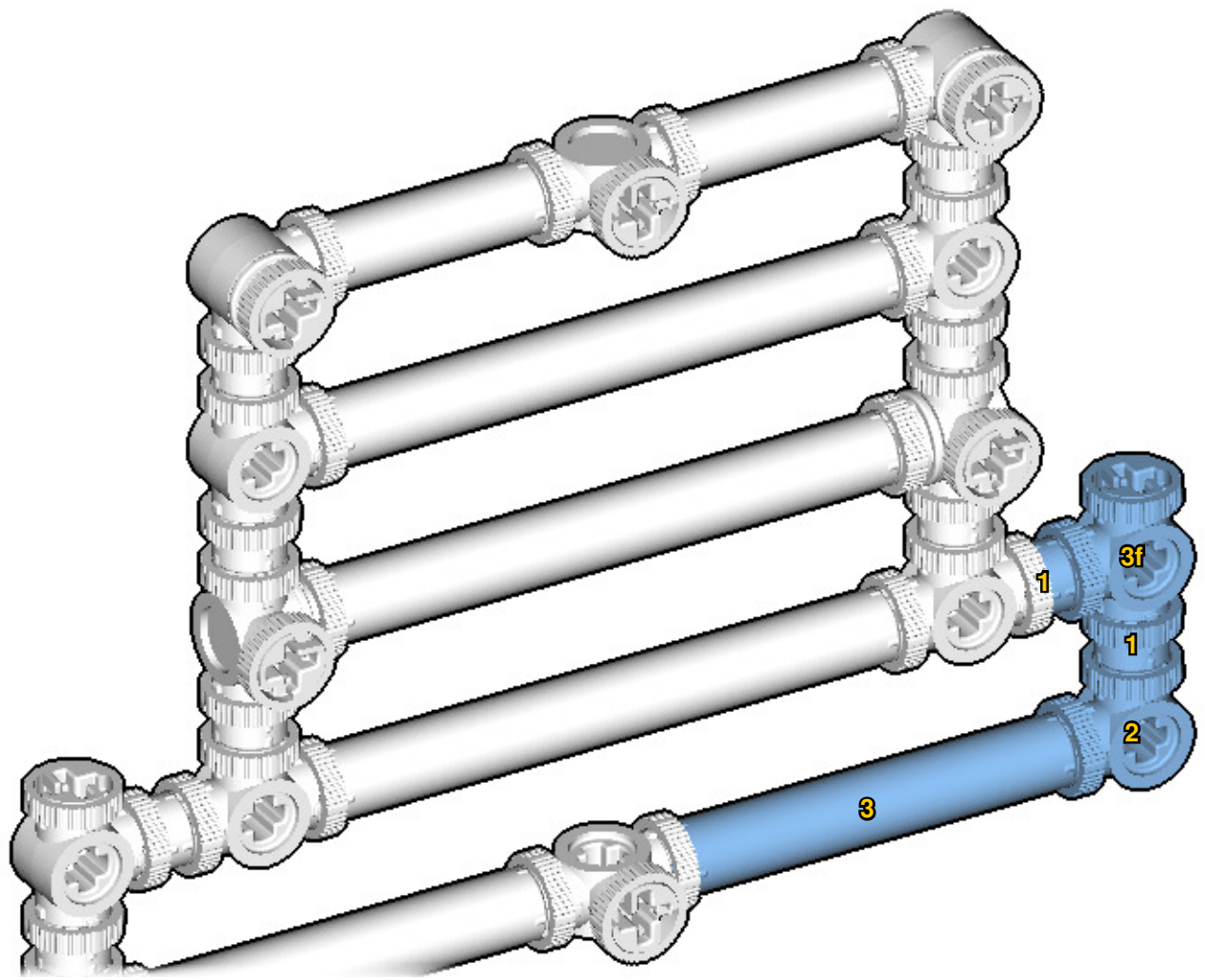

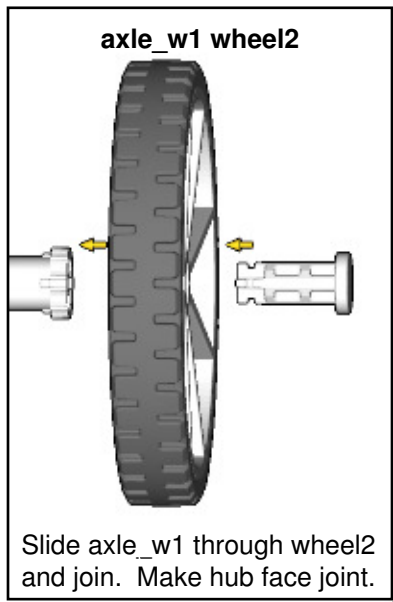
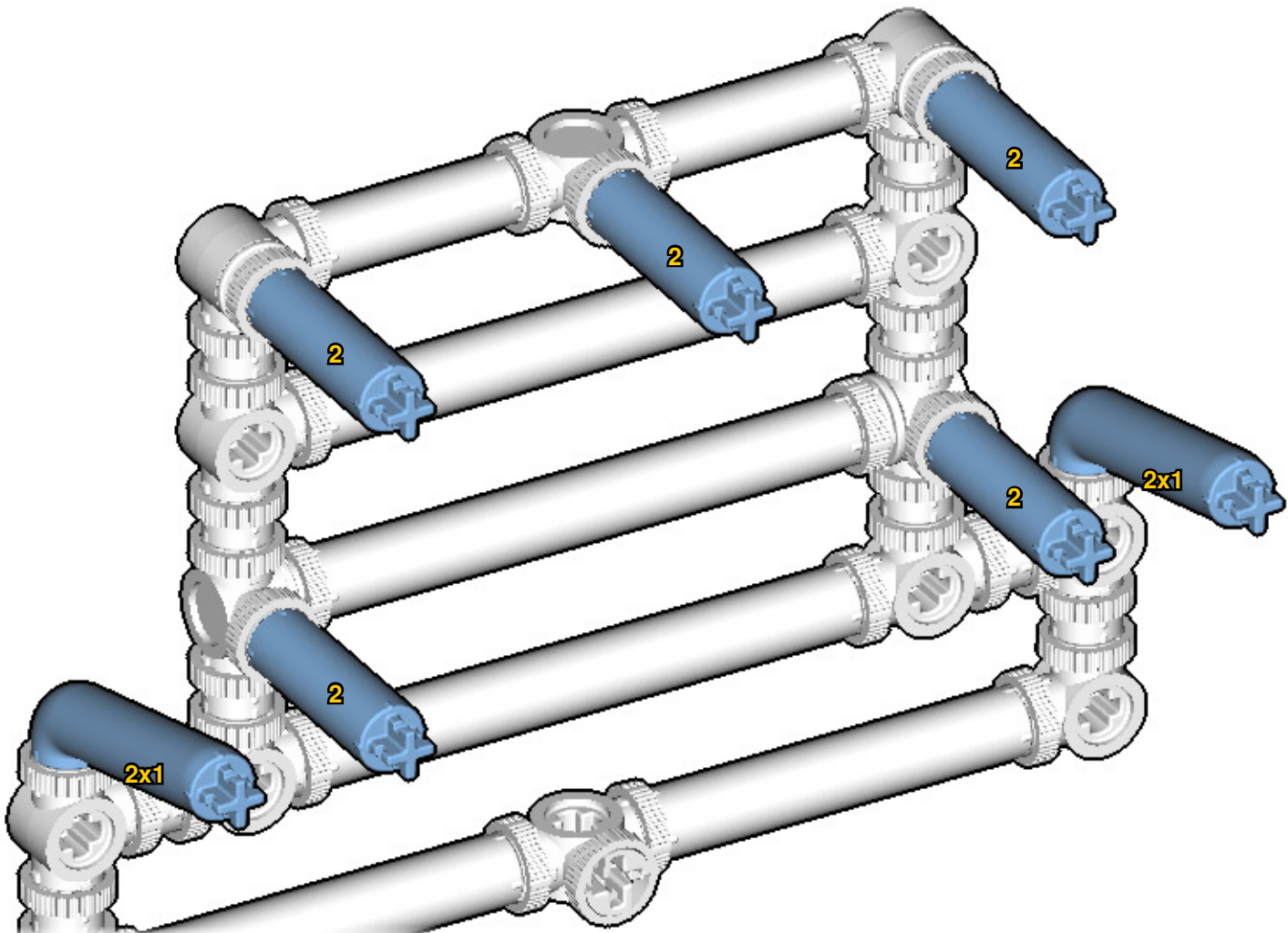

Slide axle_w1 through wheel2 and join. Make hub face joint.

Submodel begins → **18**

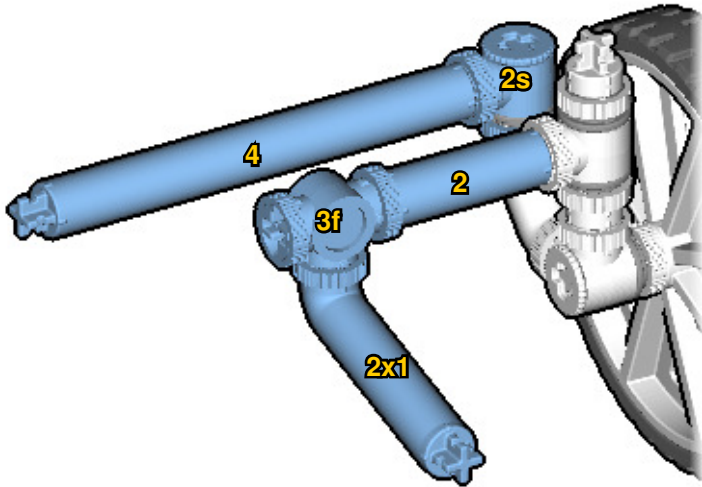

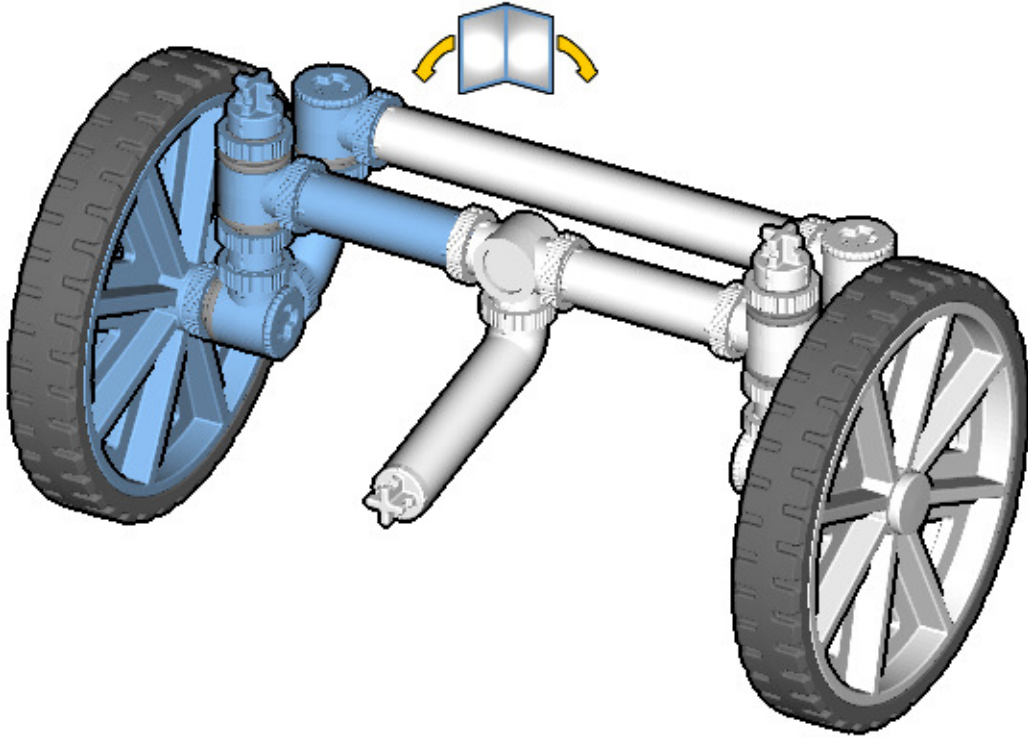

 : Copy new pieces from old pieces.

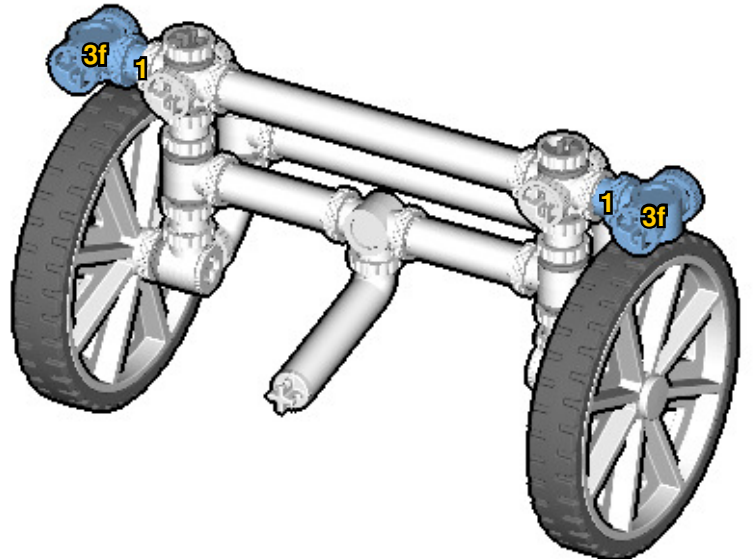
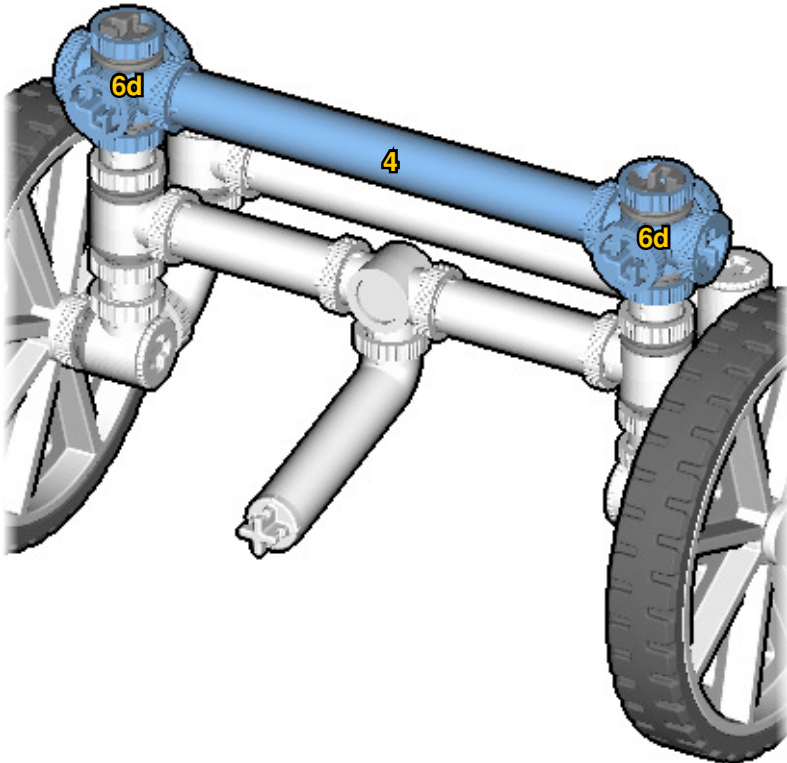

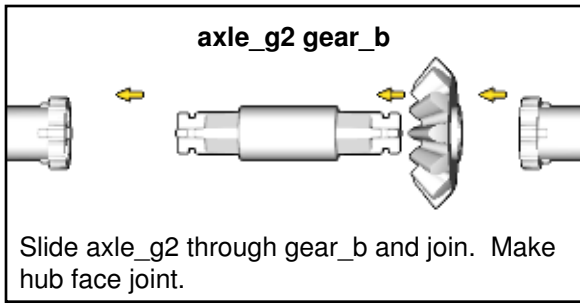

13

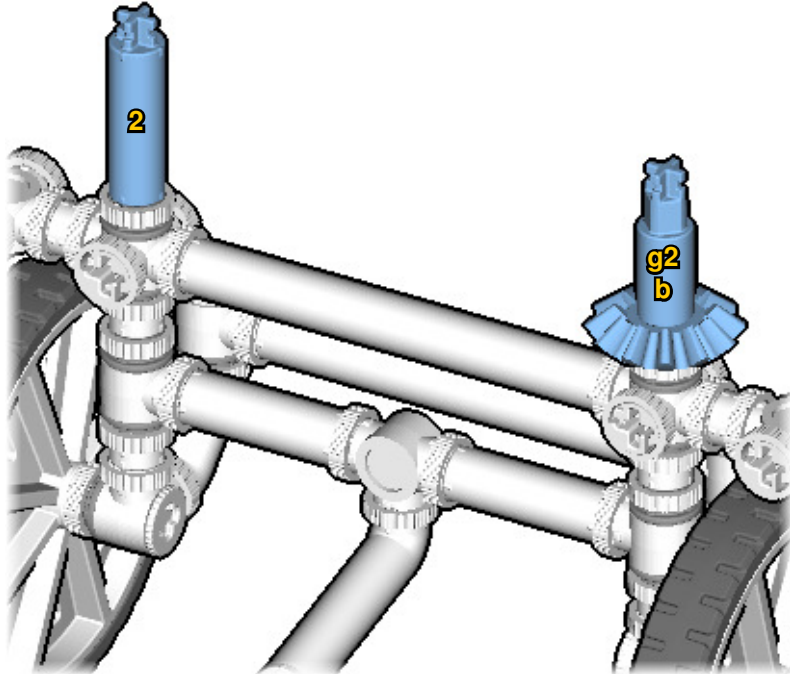

14

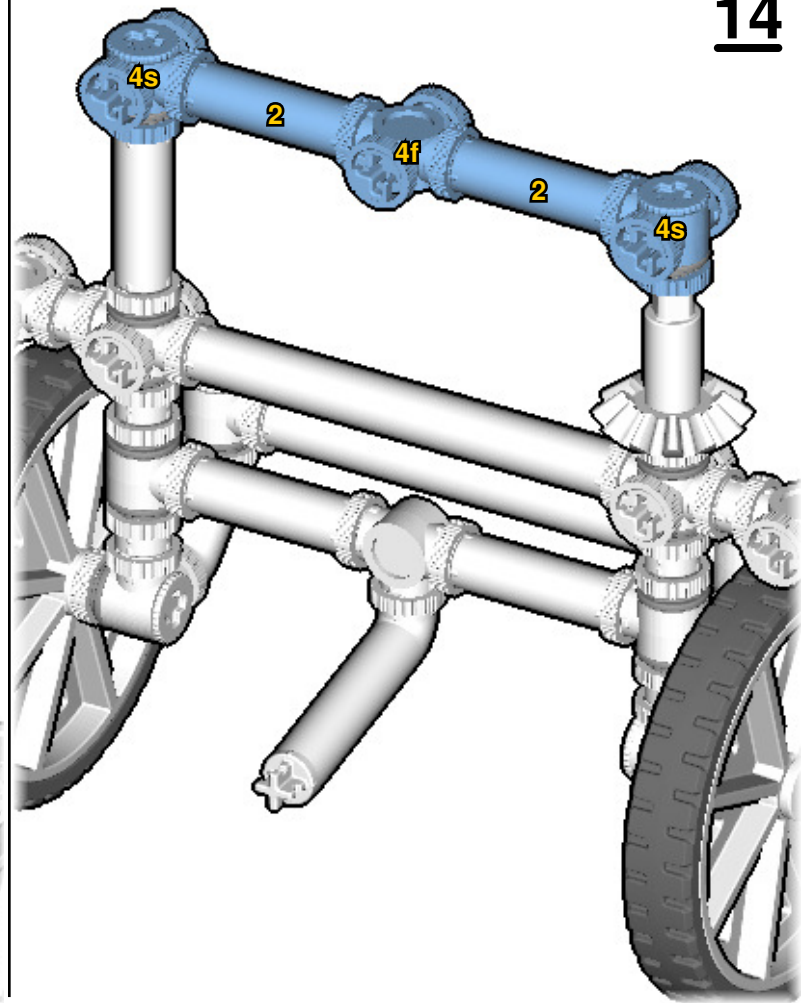

15

Submodel ends →

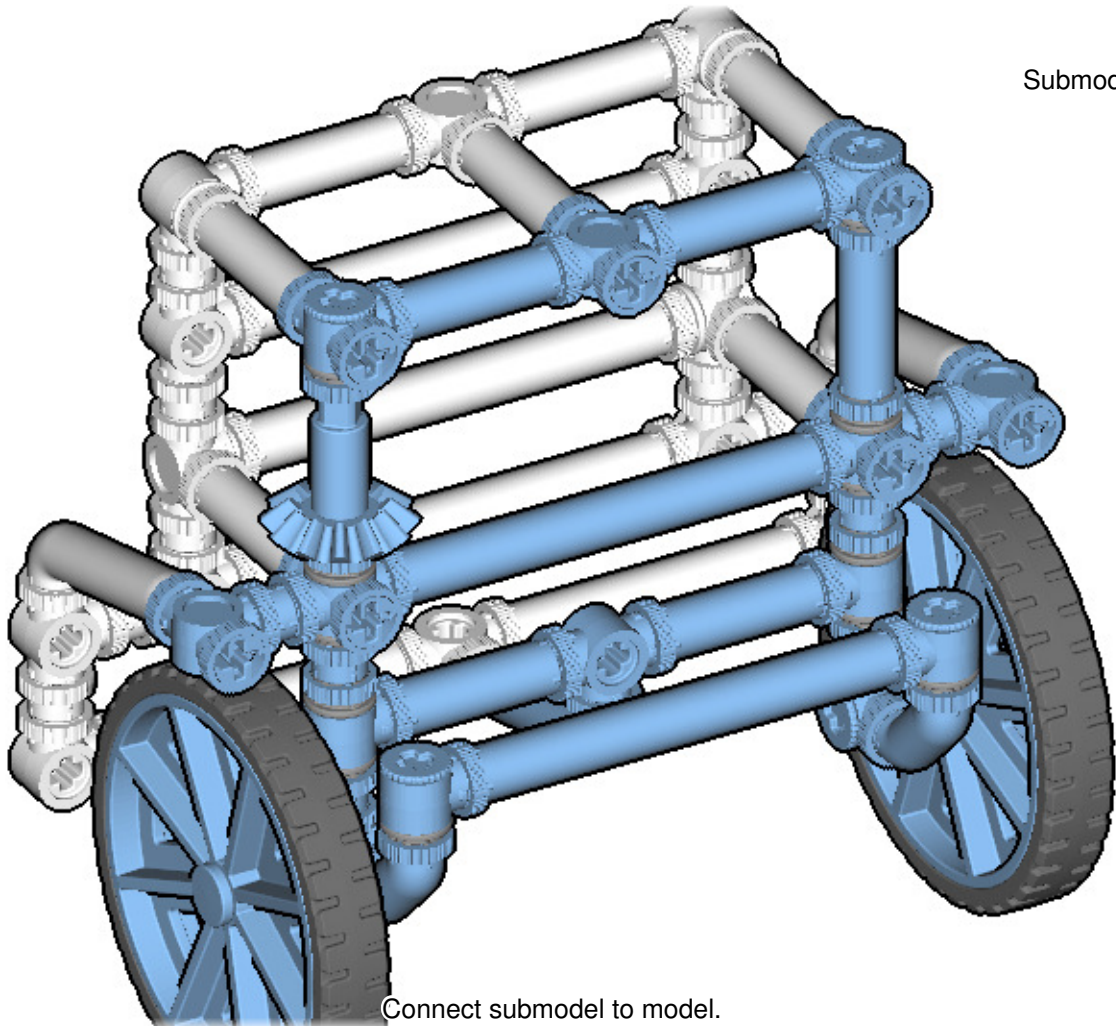

Connect submodel to model.

16

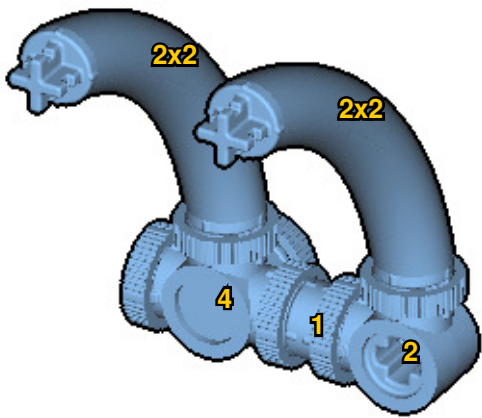

17

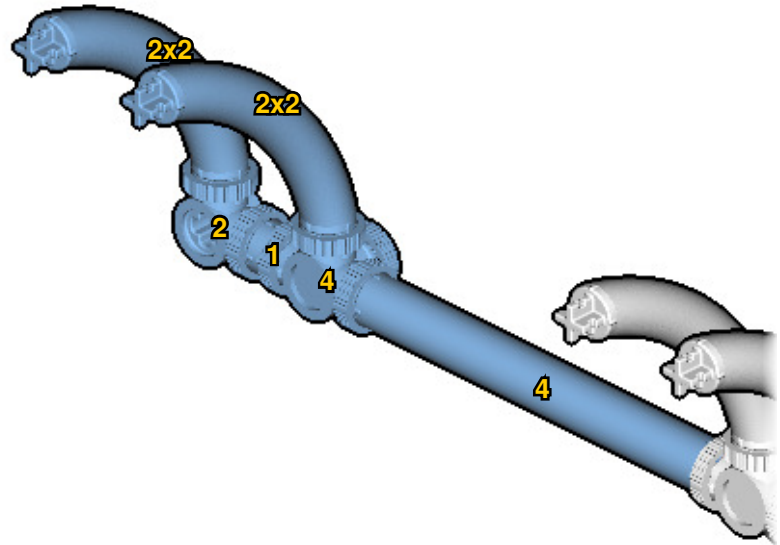

18

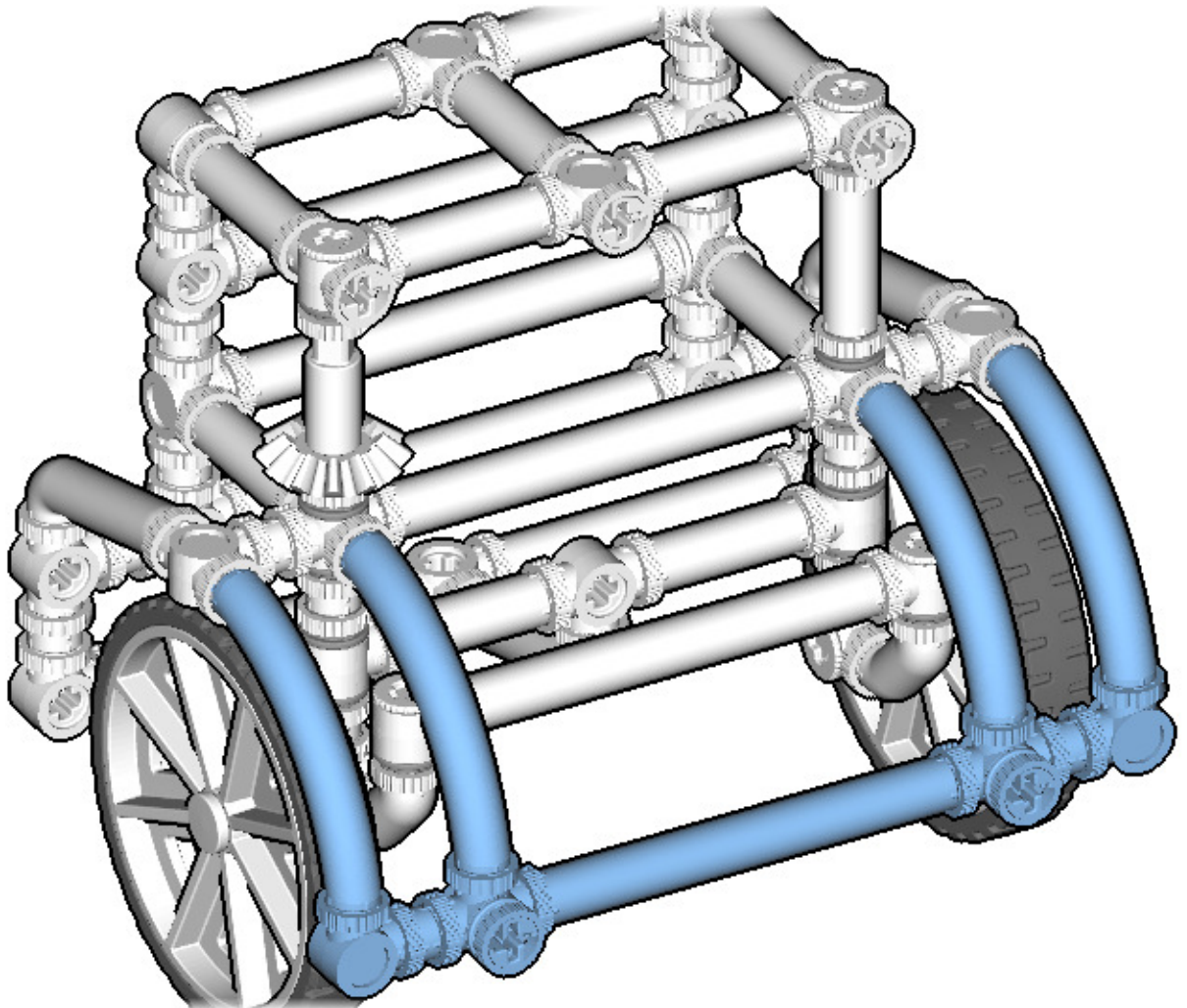

19

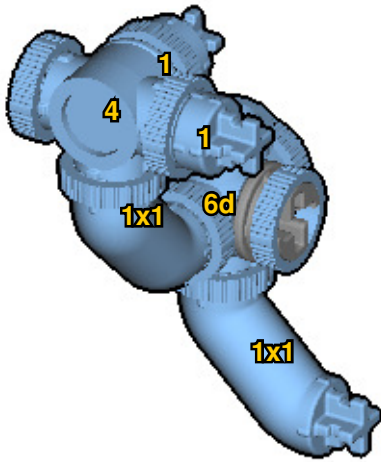

20

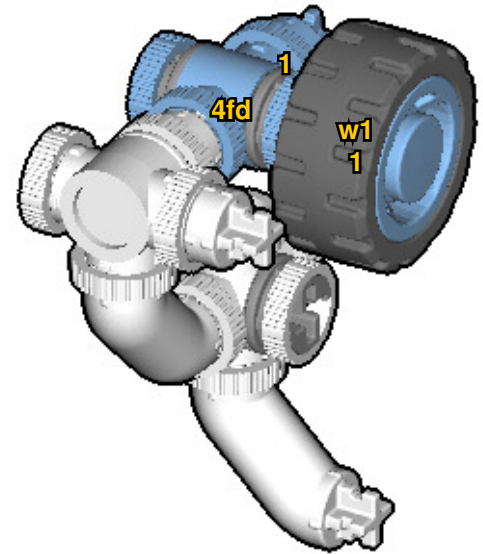
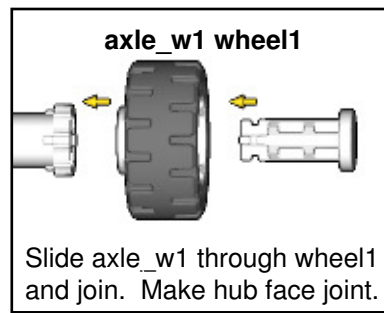

21

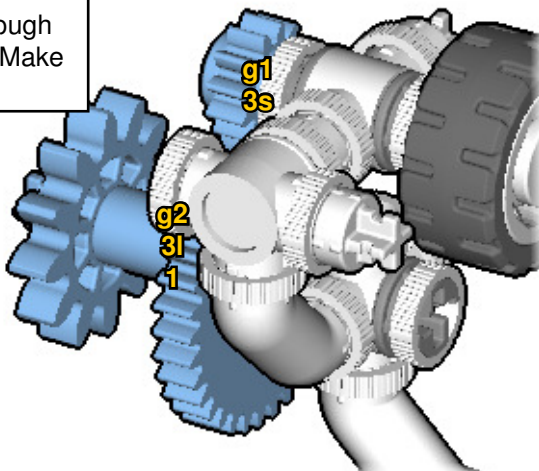
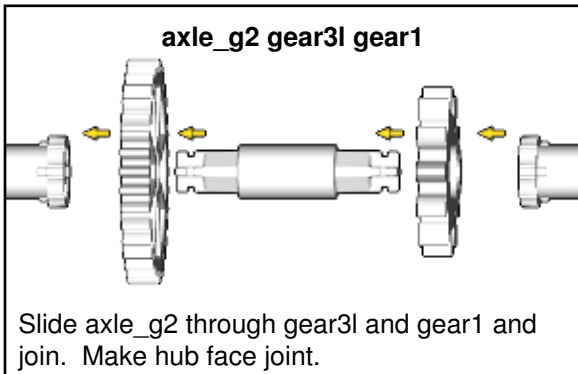

22

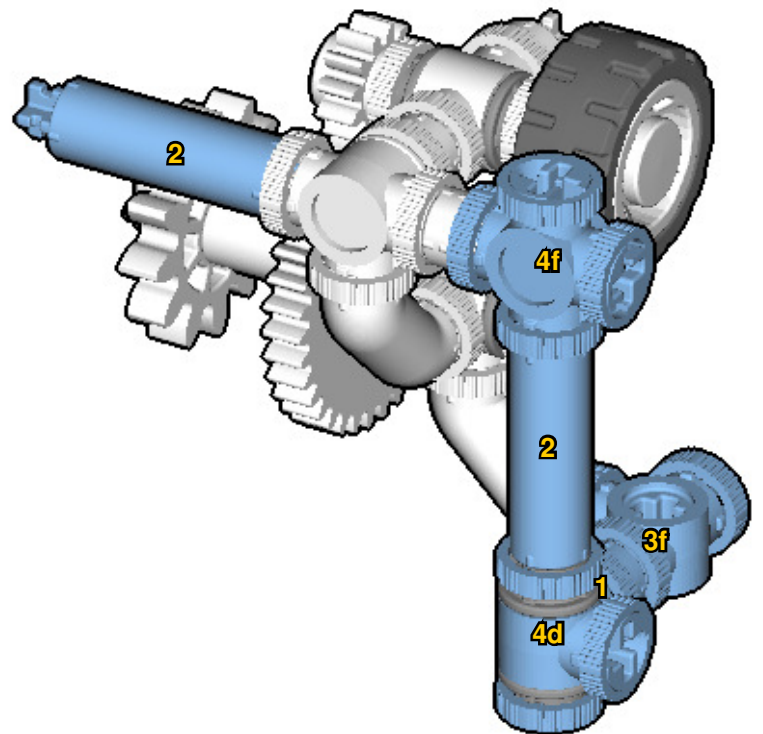

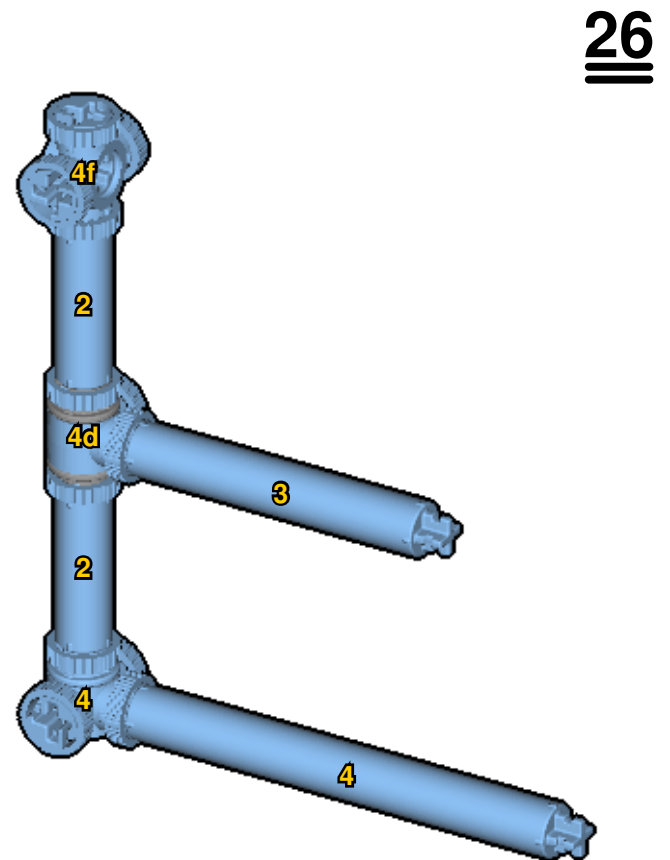
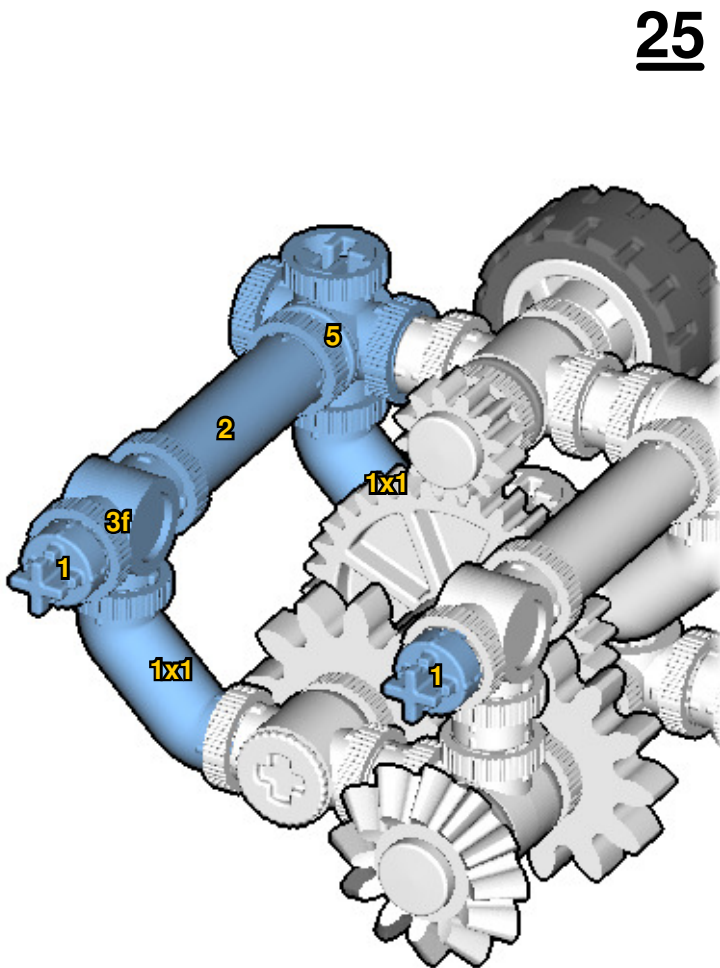
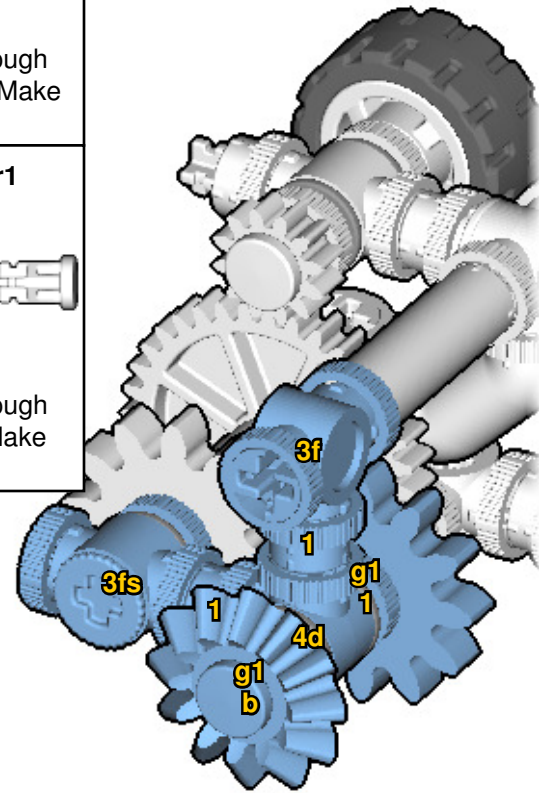
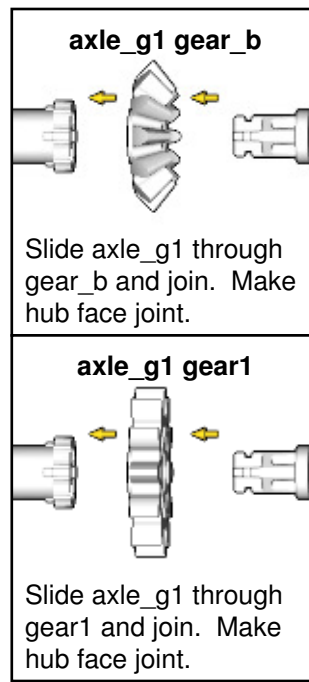
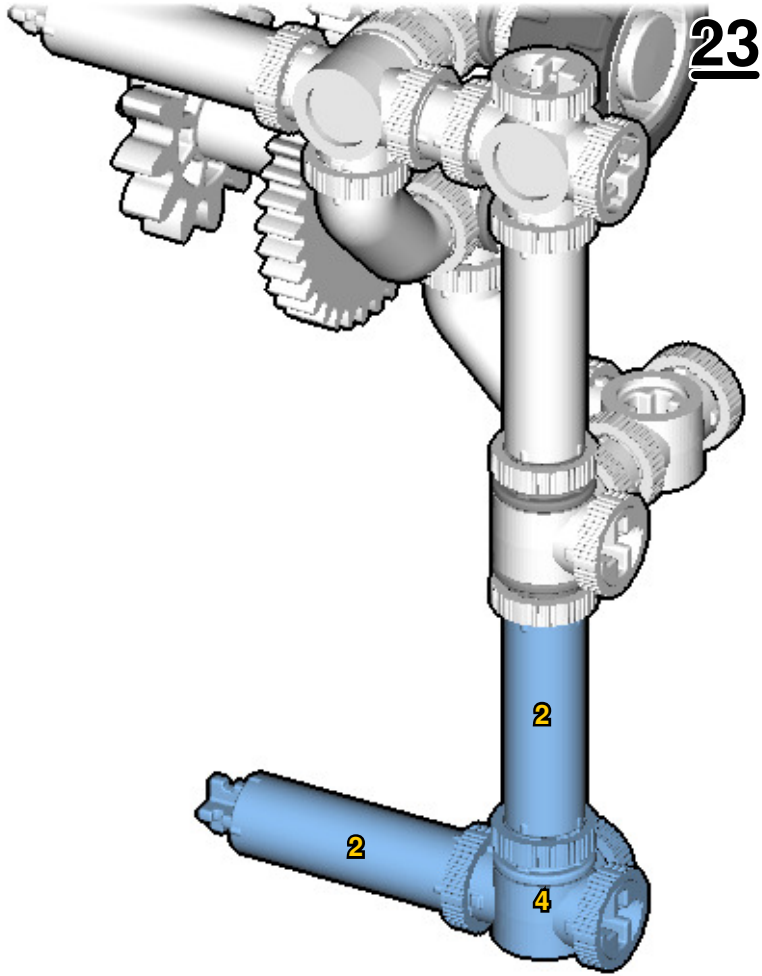

27

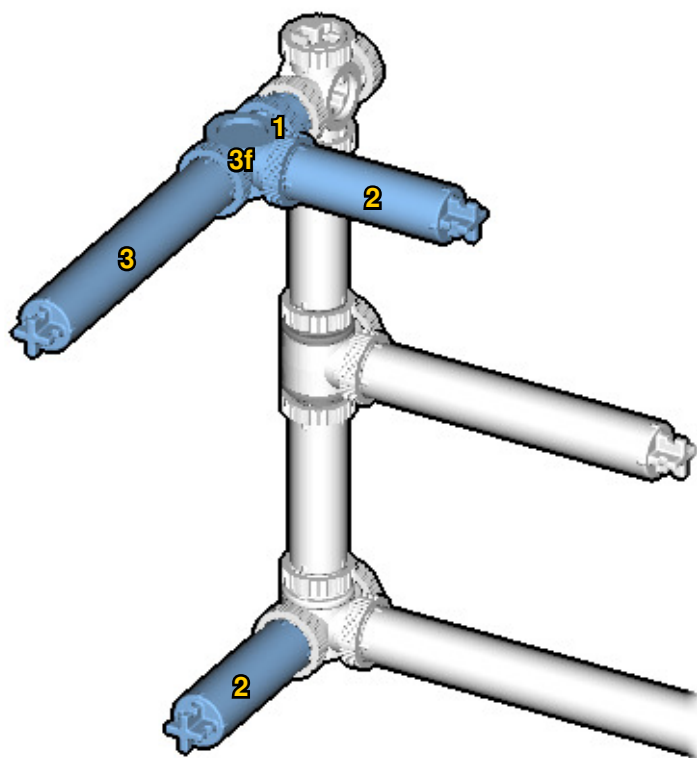

28

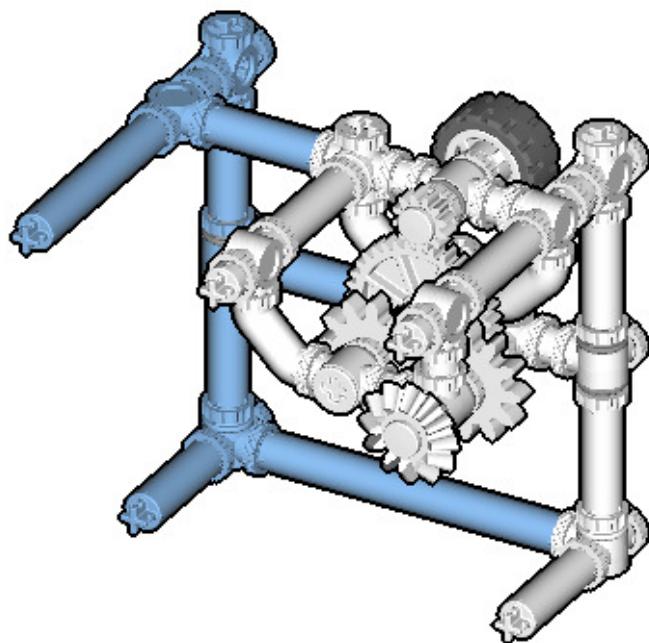

29

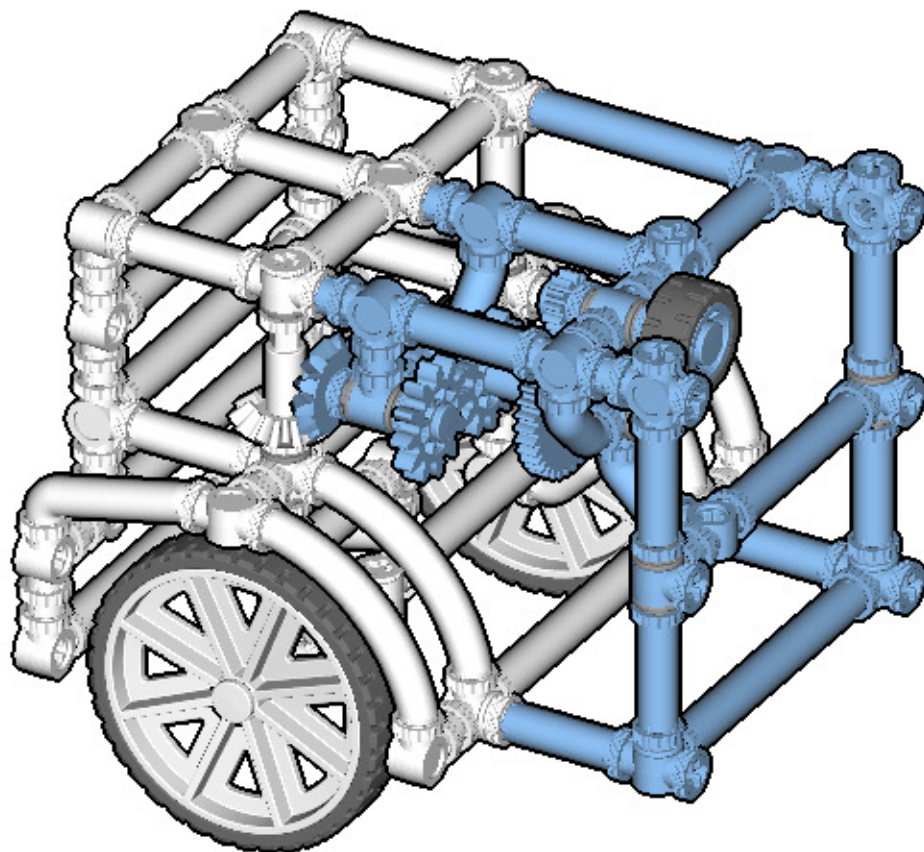

30

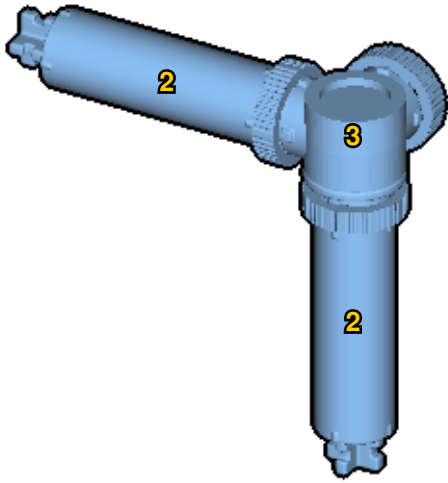

31

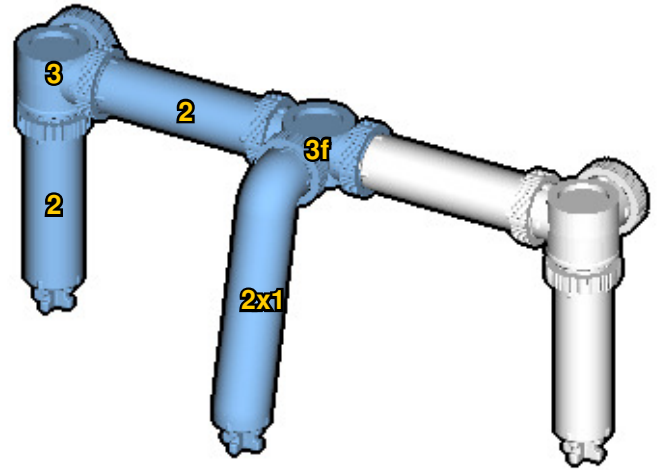

32

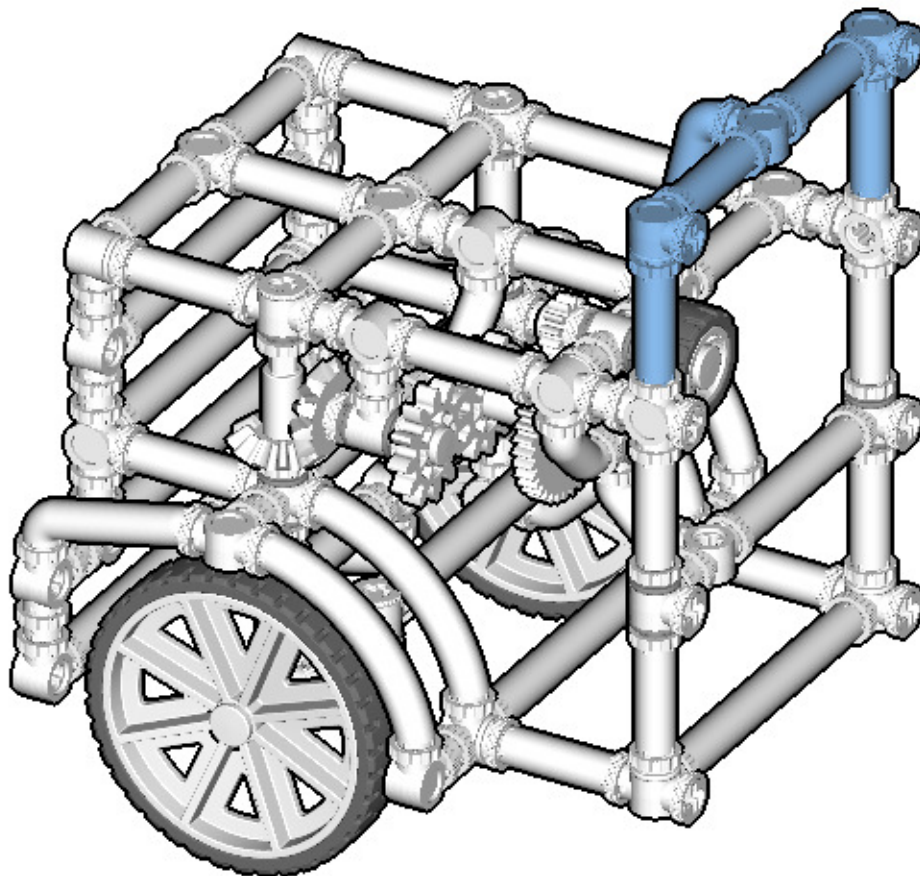

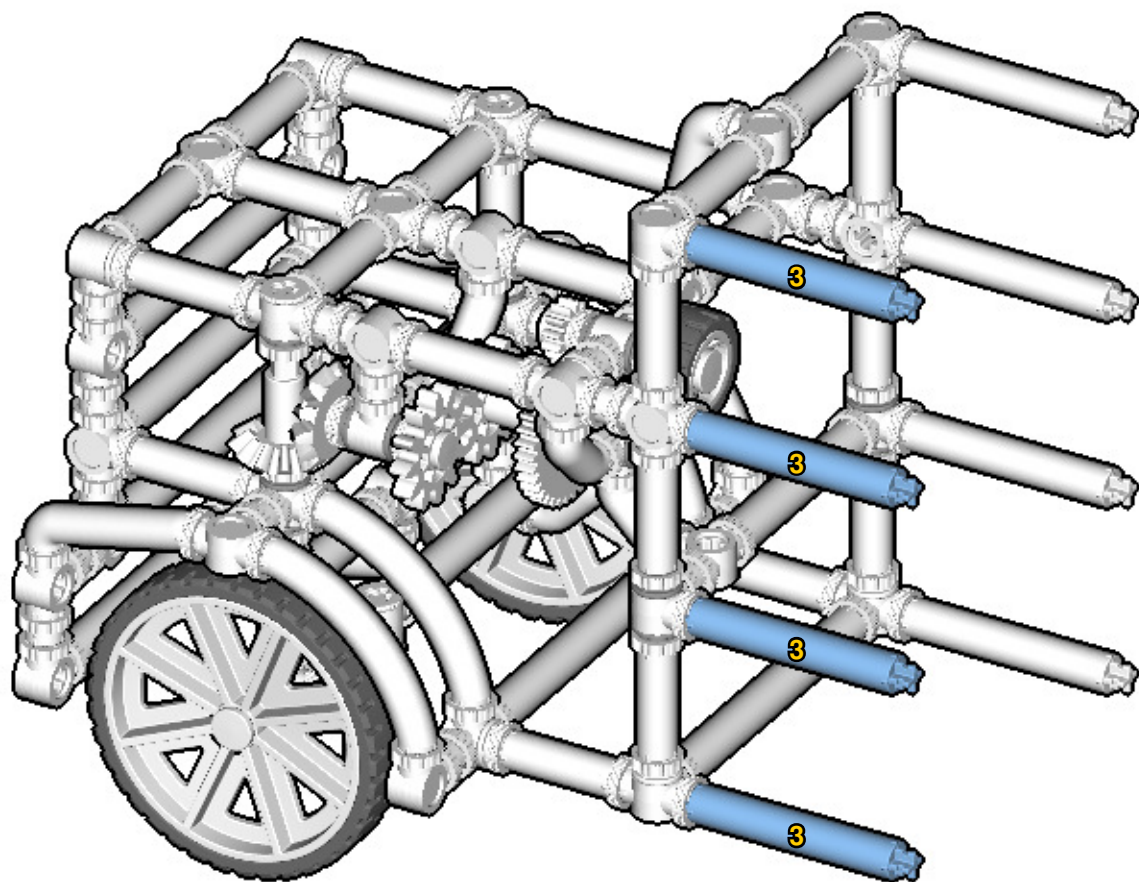
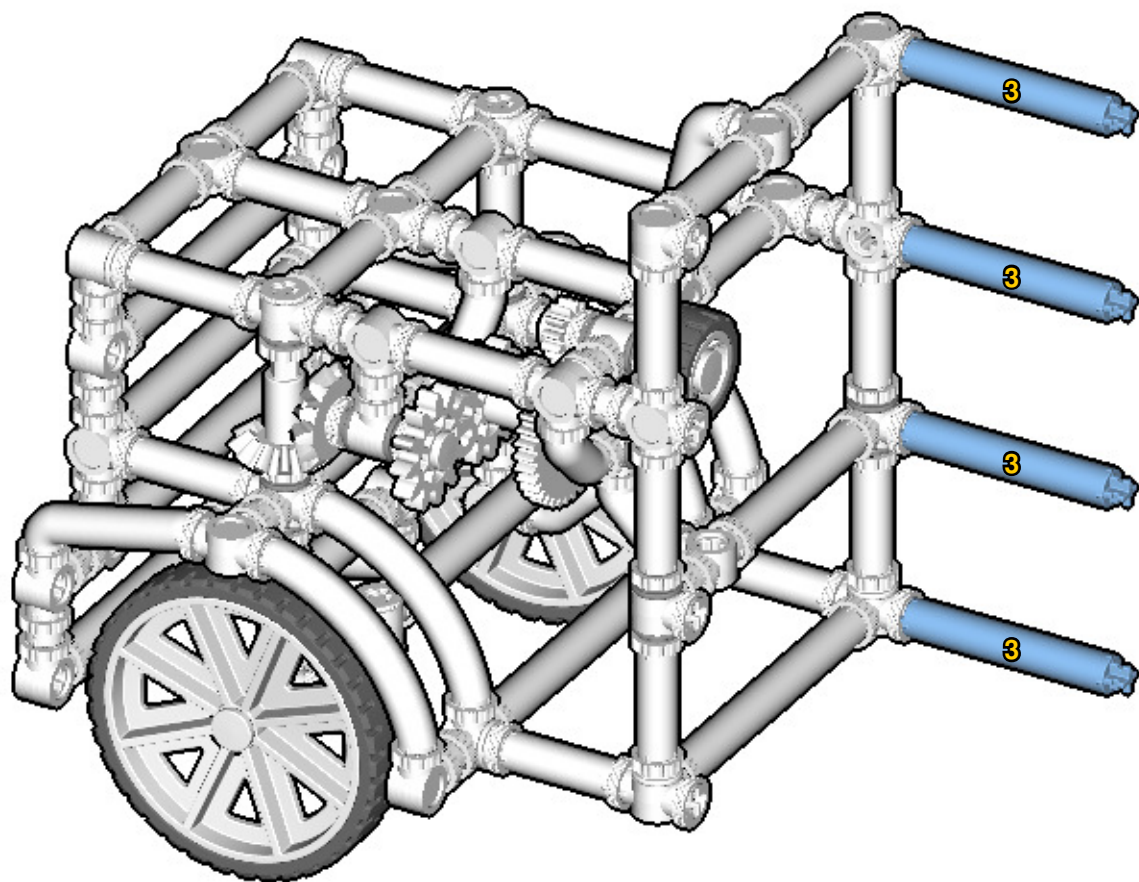

35



36

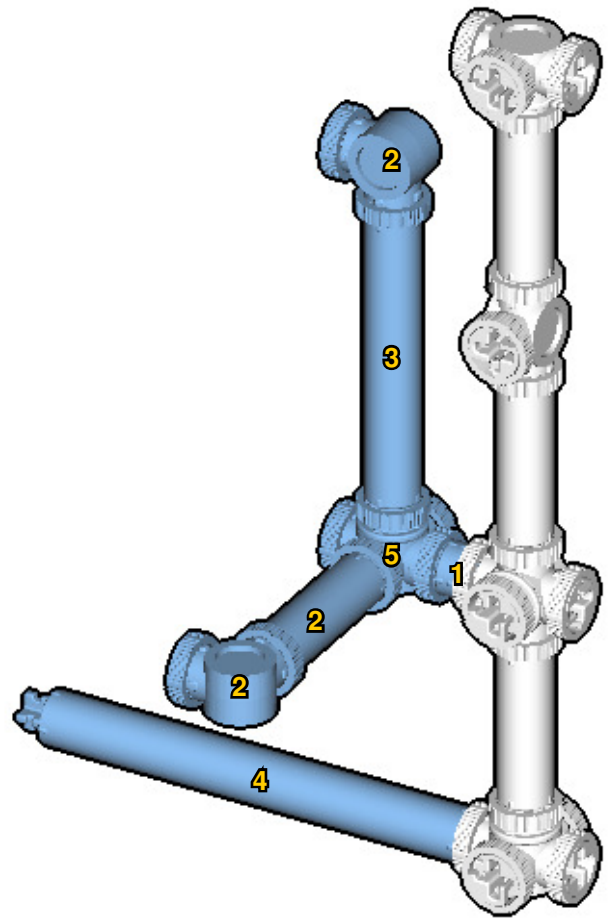

37

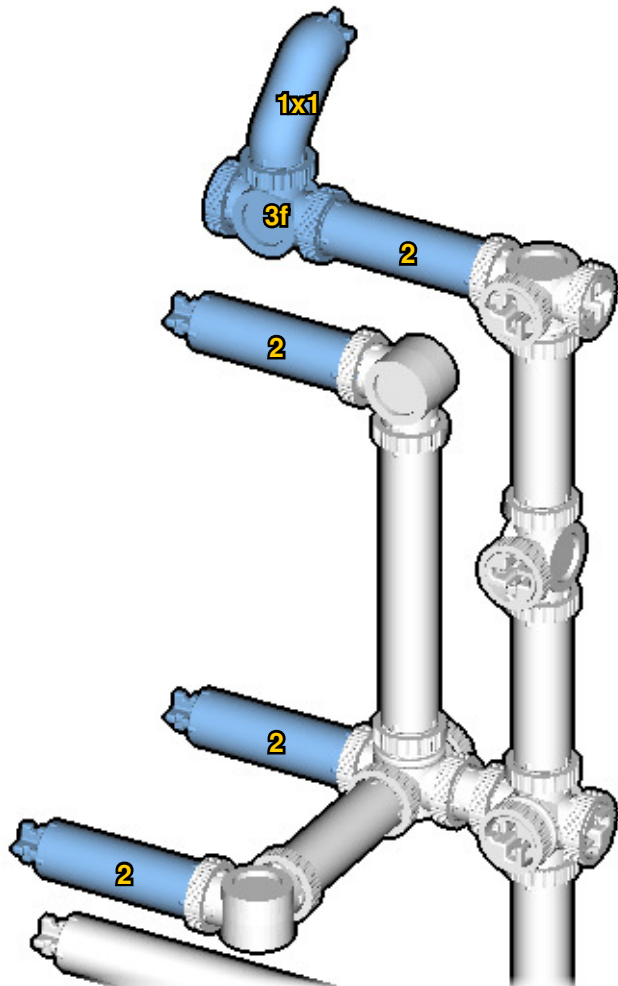

38

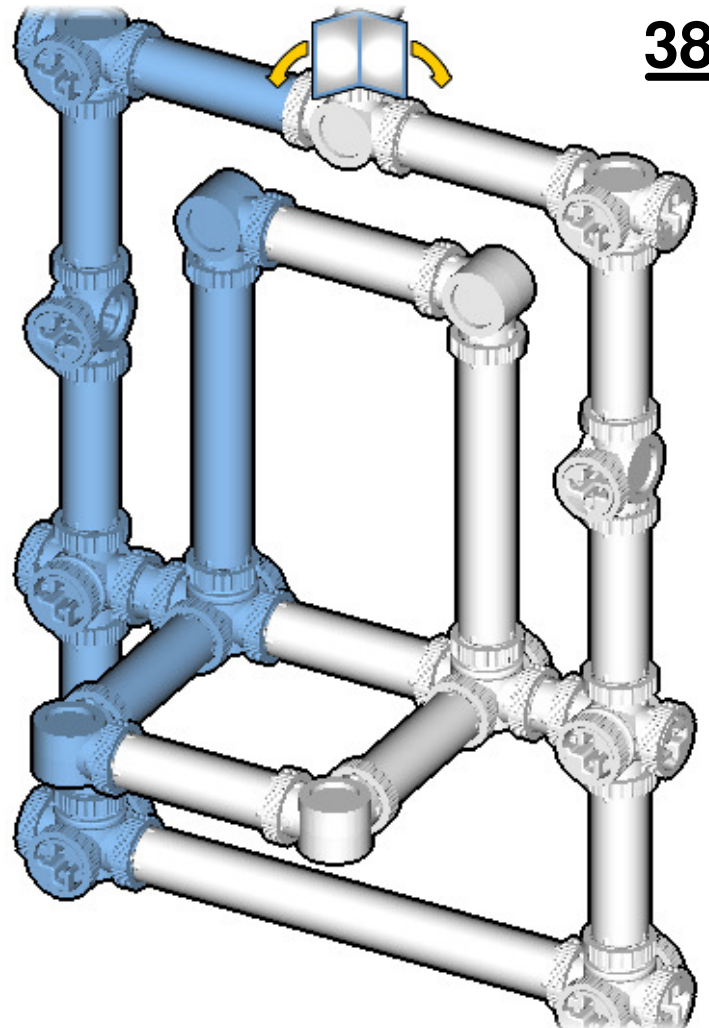

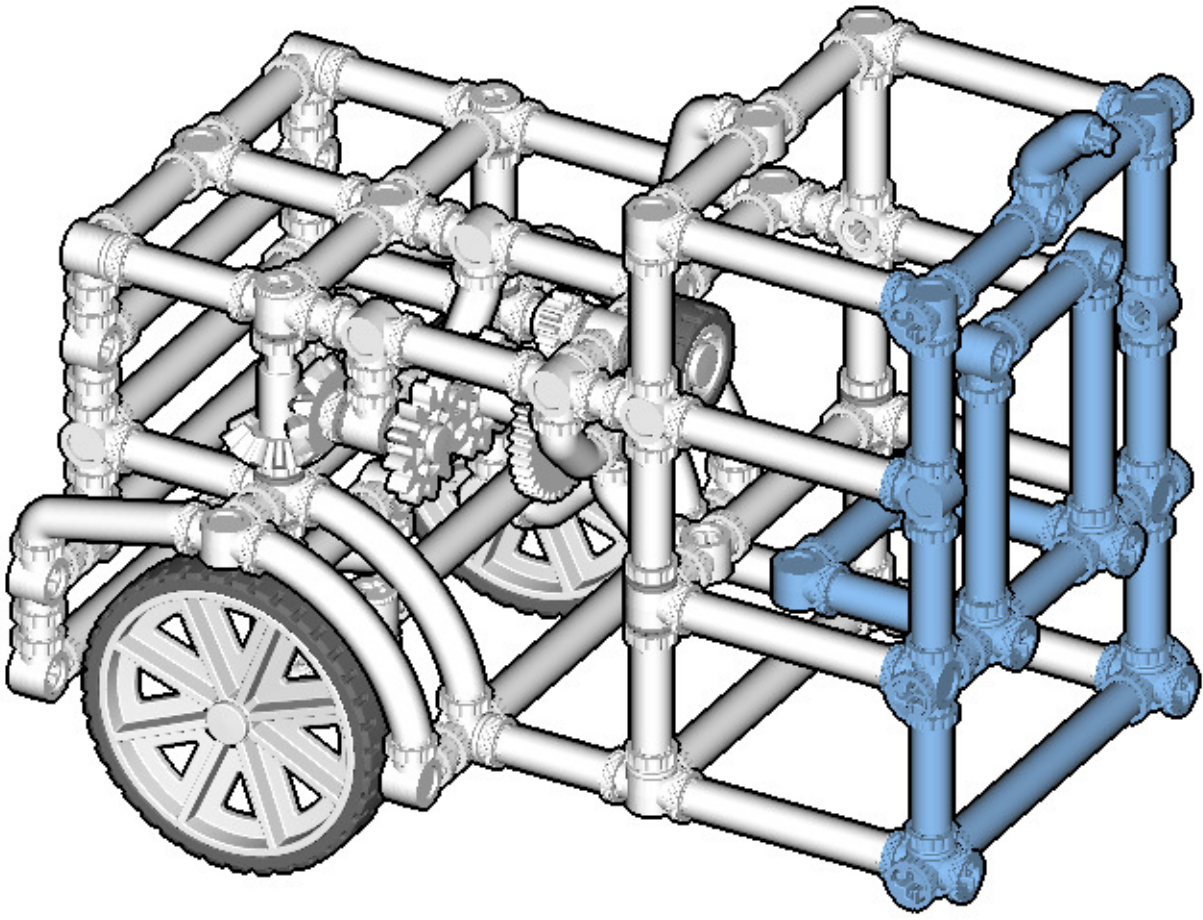

40



41

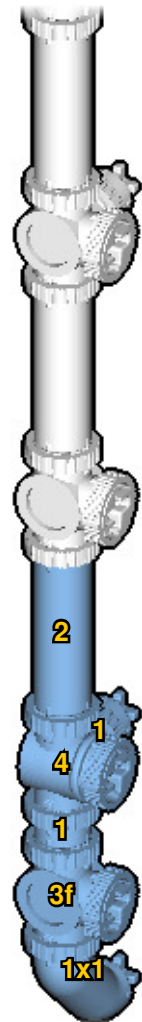

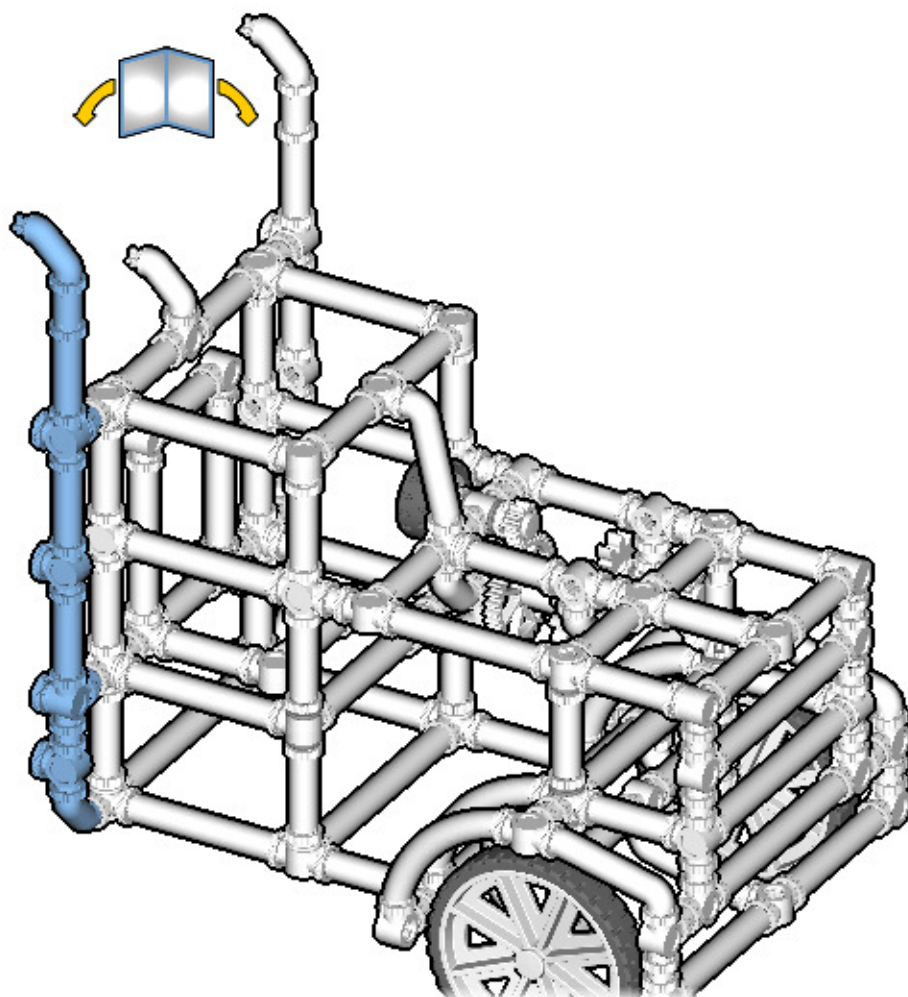
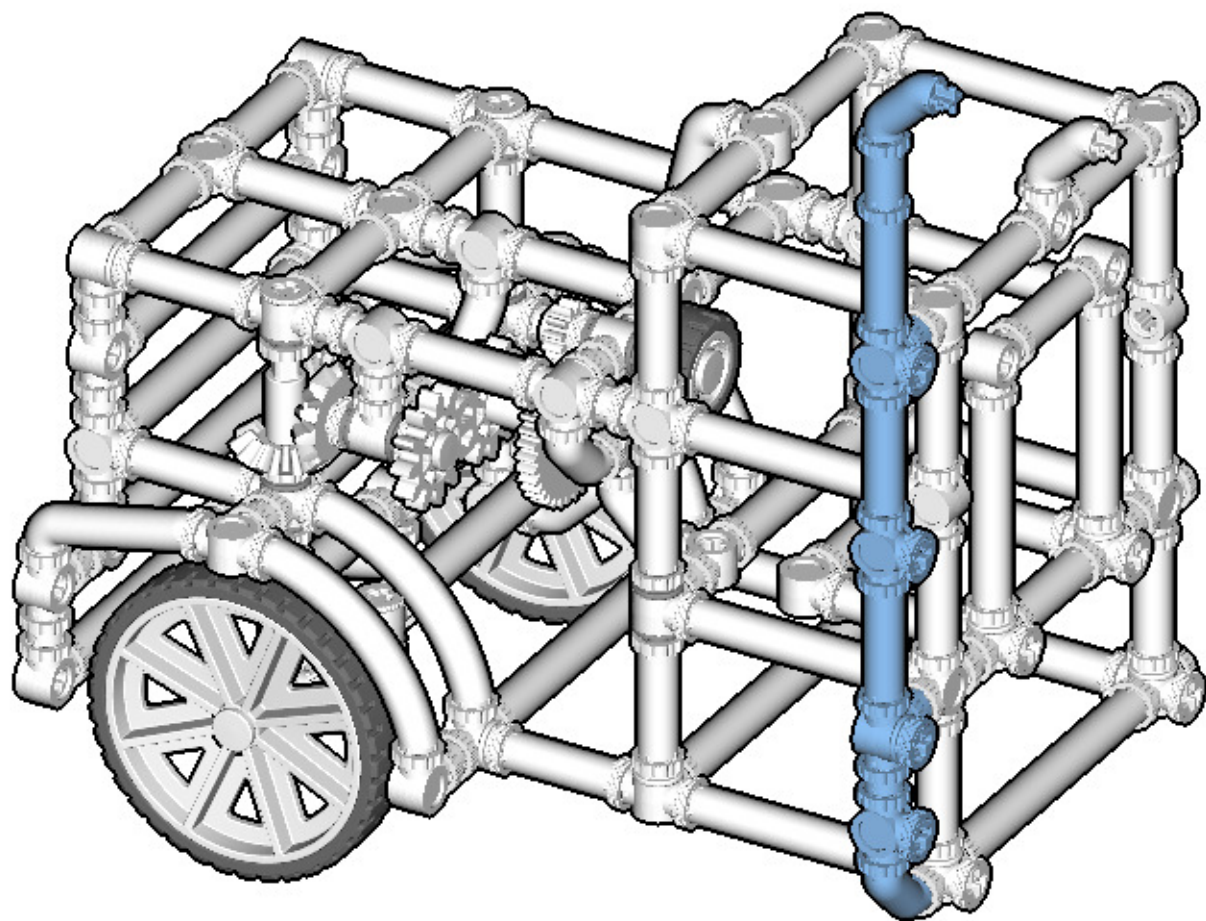

44

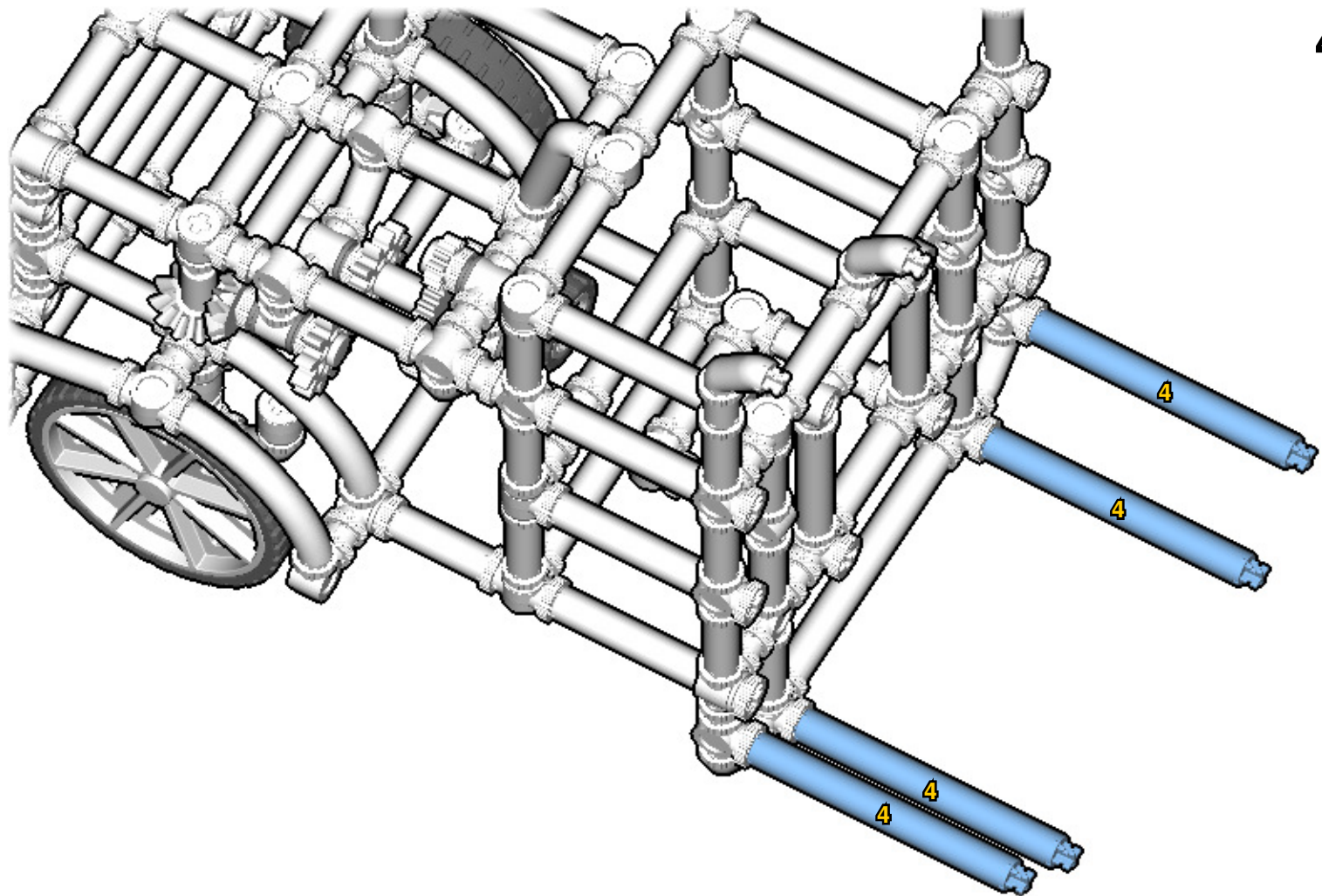

45

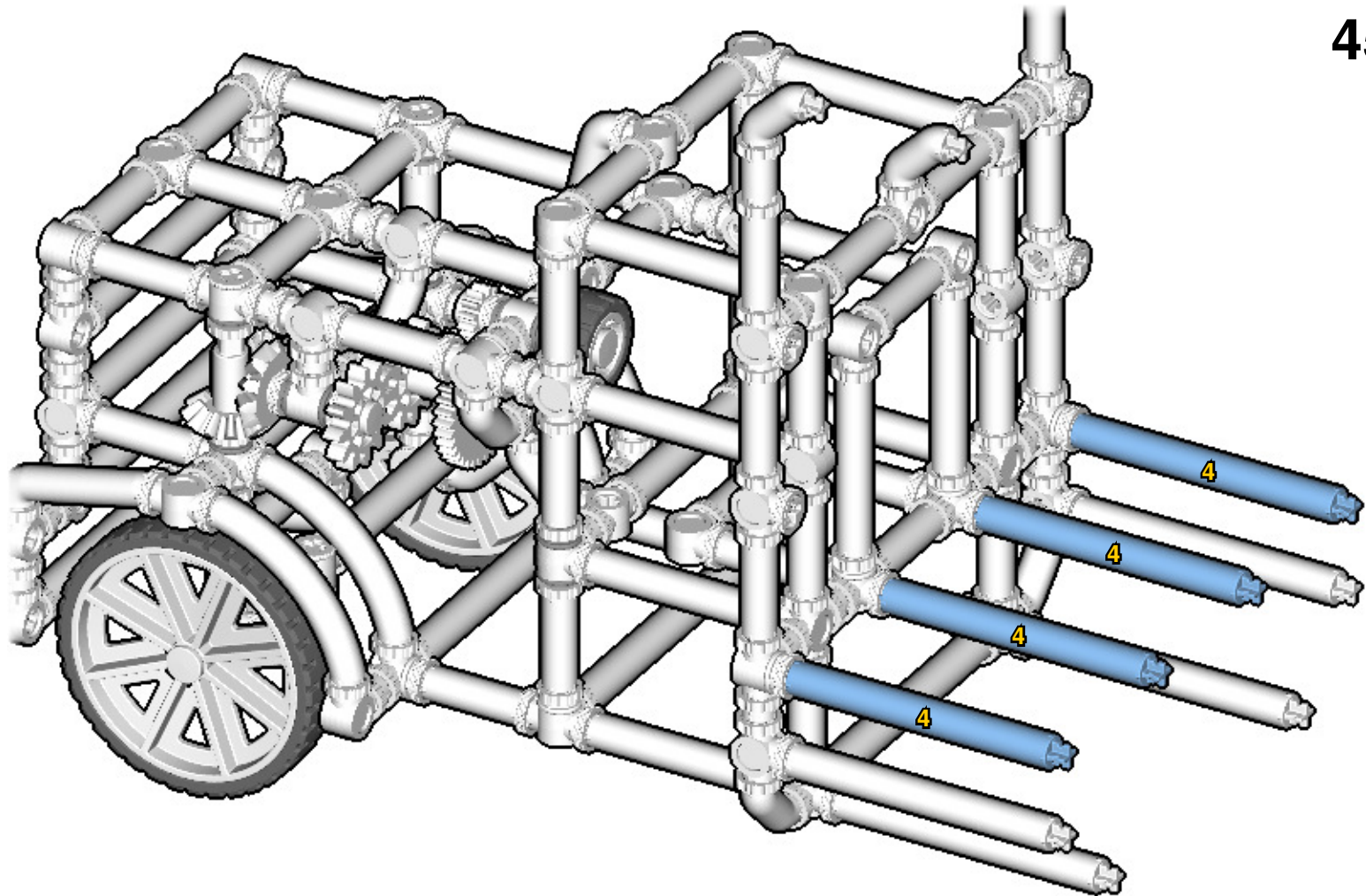

46

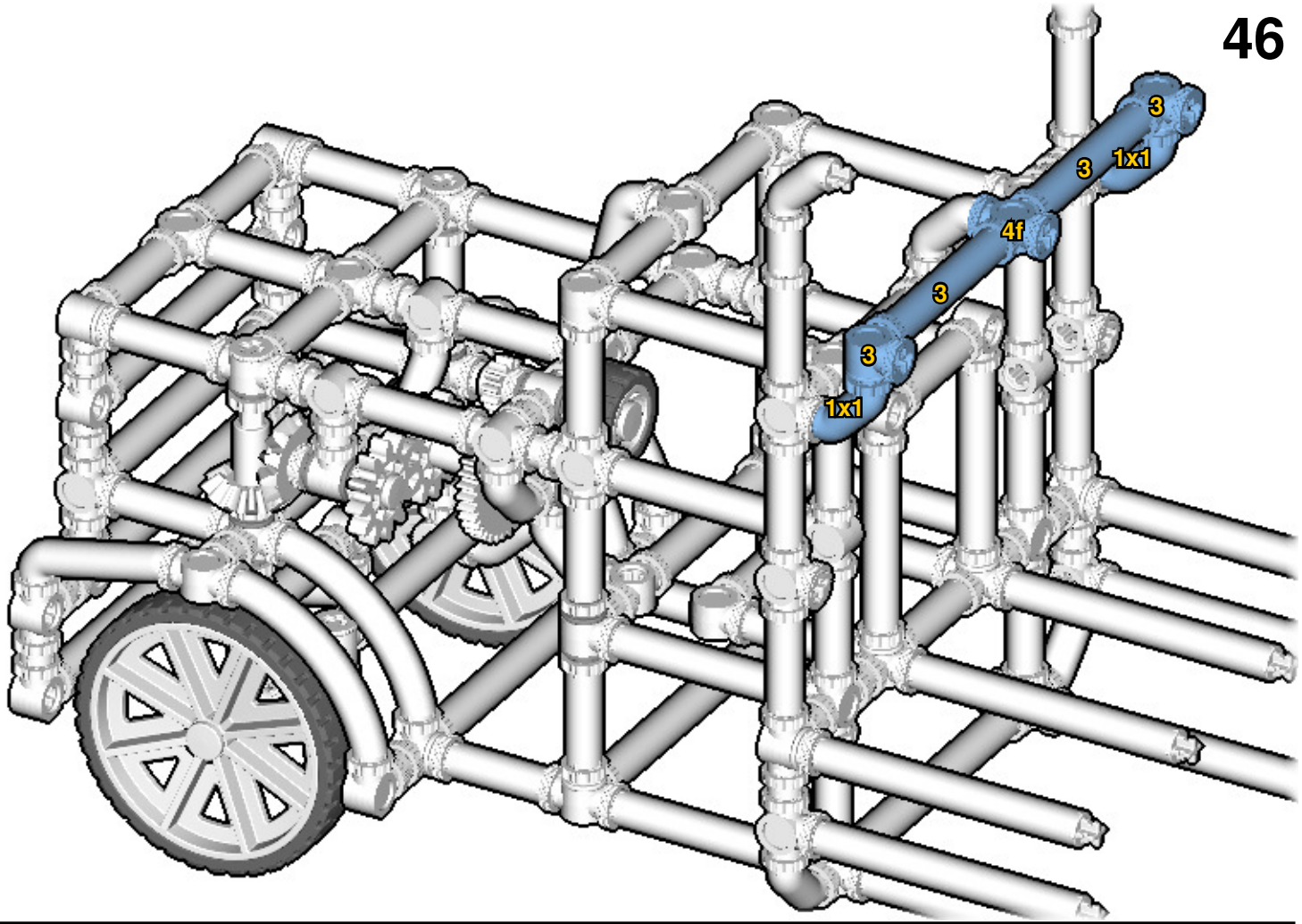

47

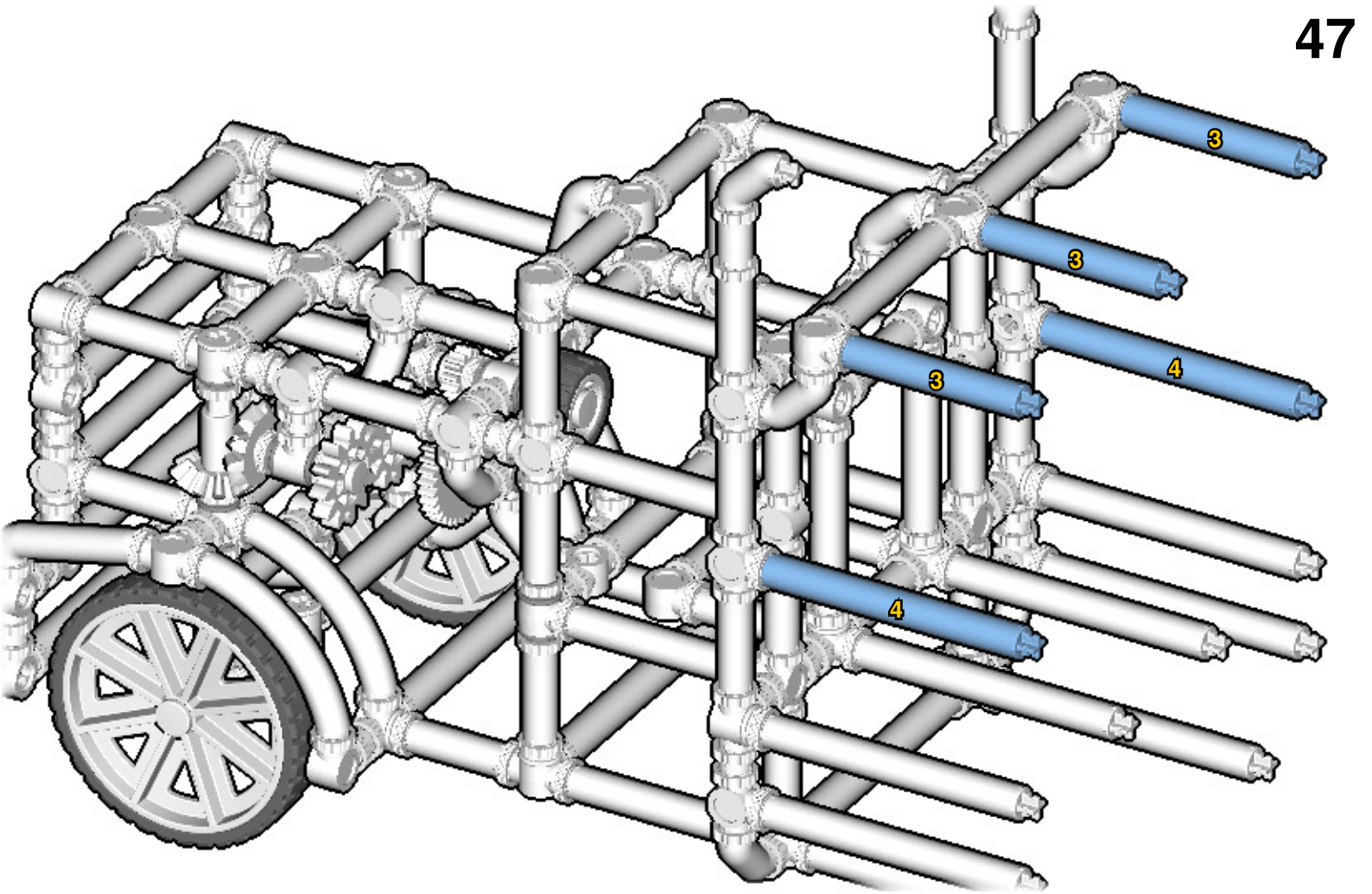

48

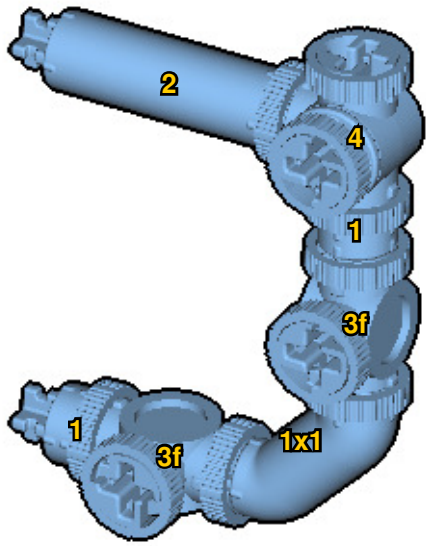

49

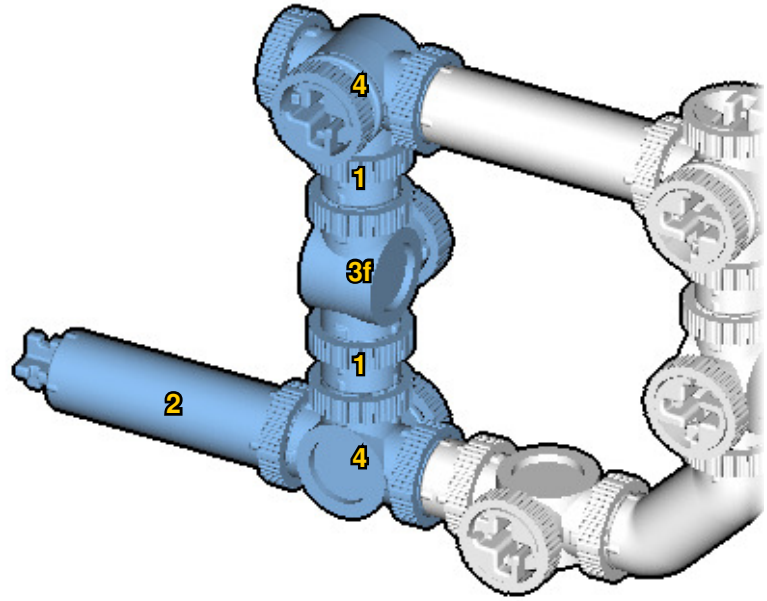

50

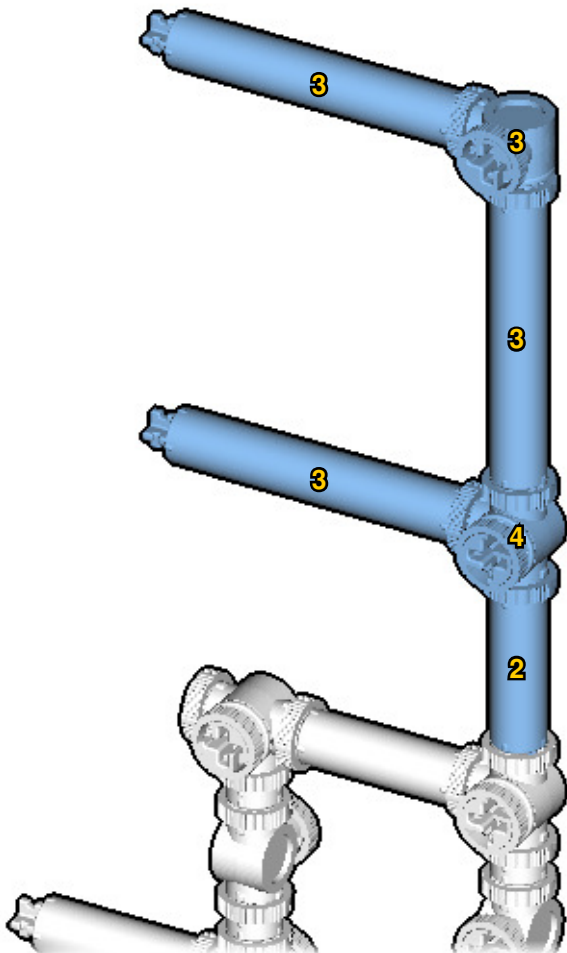

51

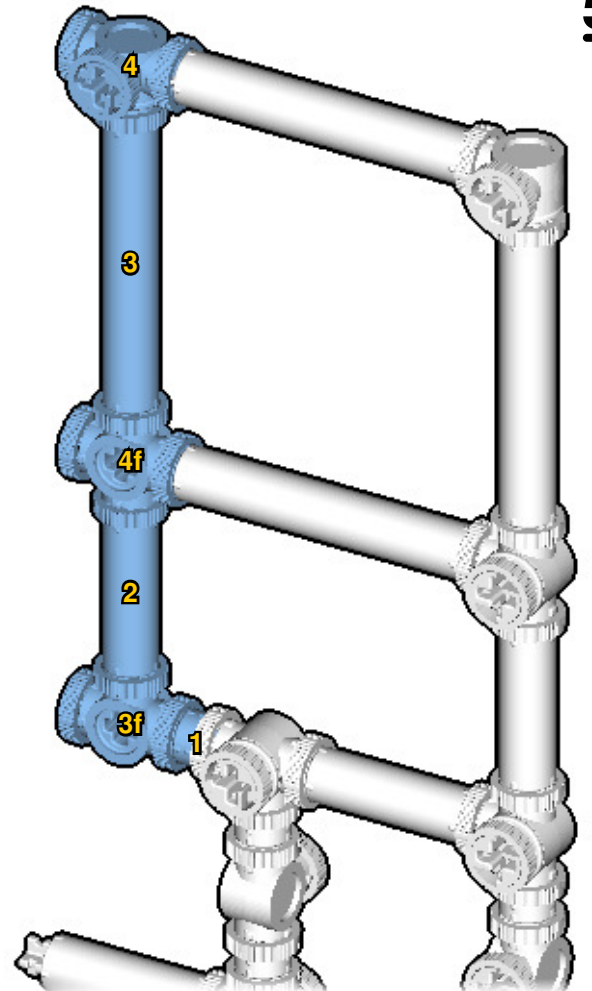

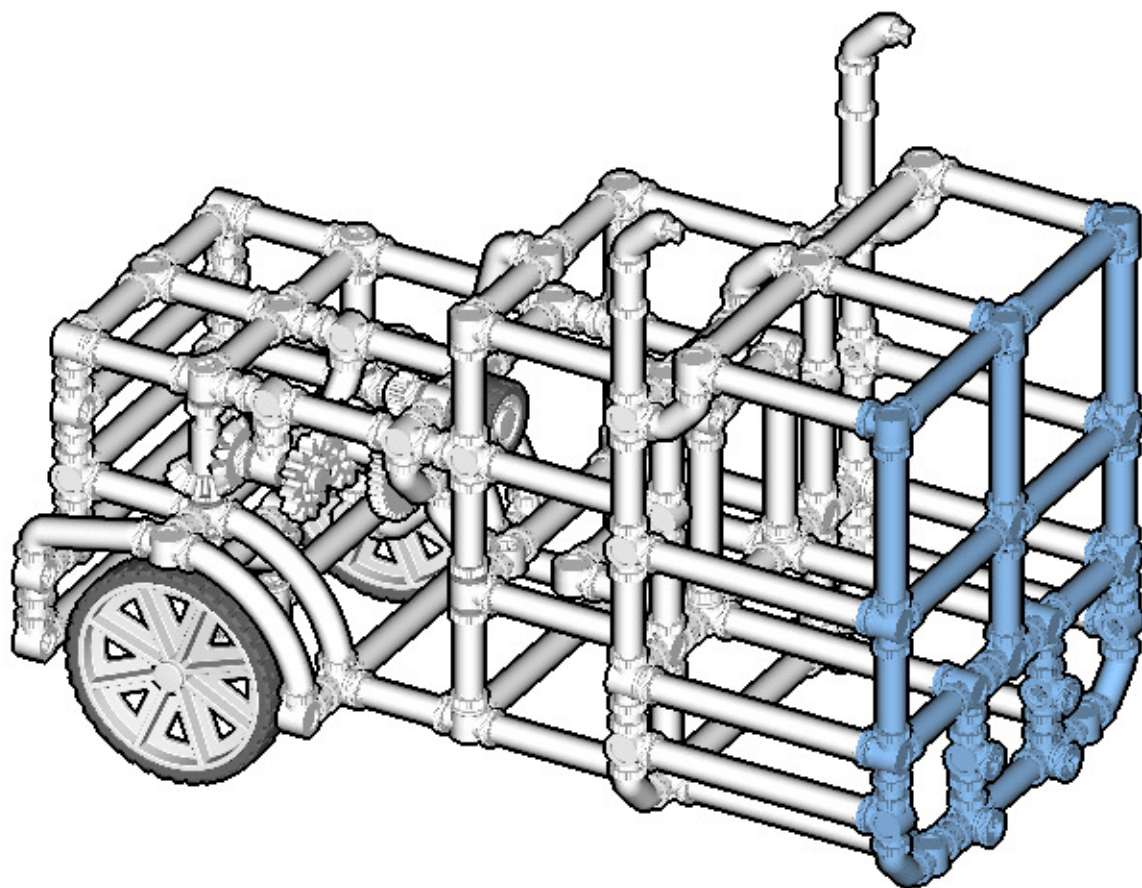
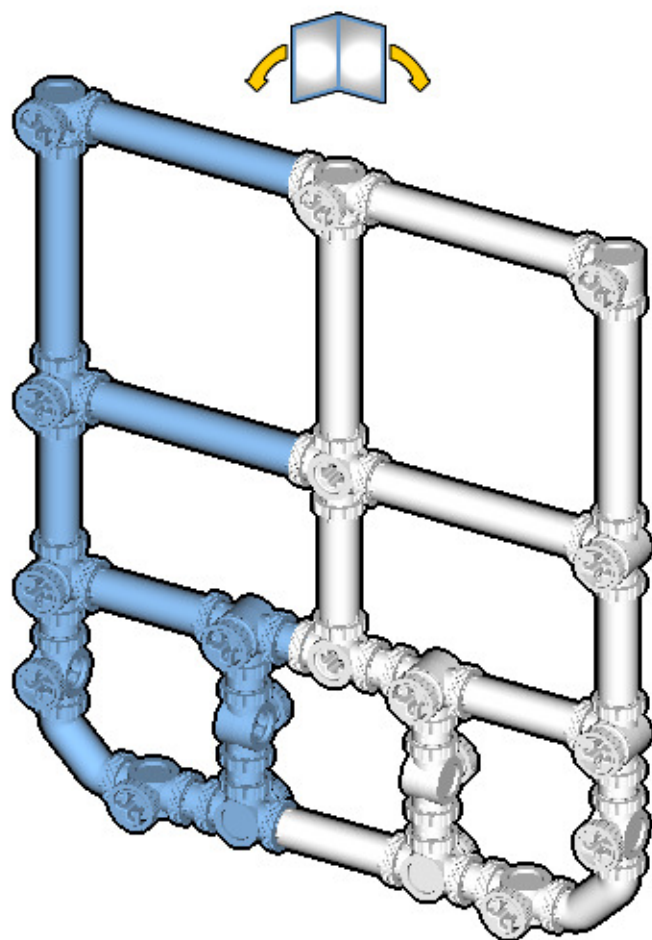

54

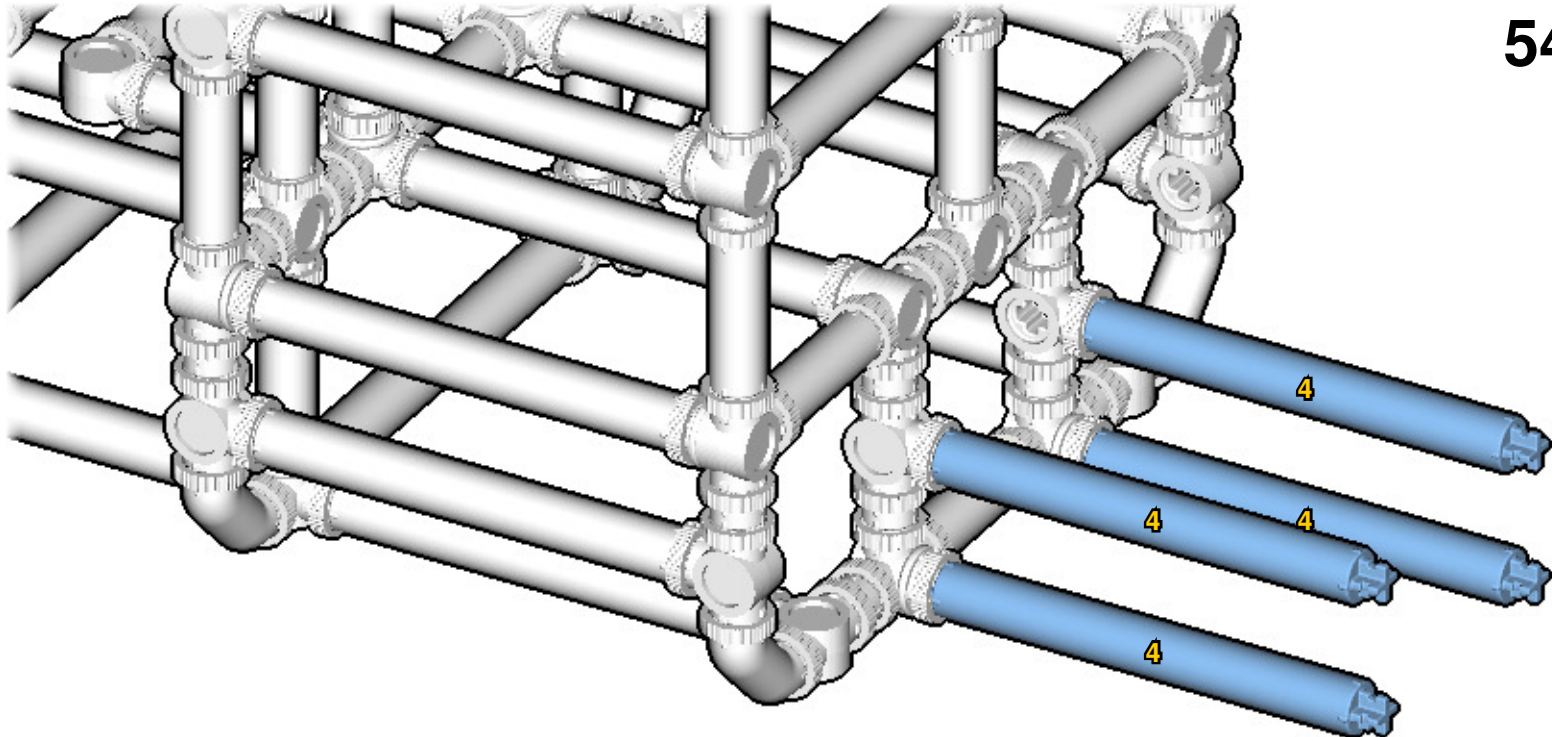

55

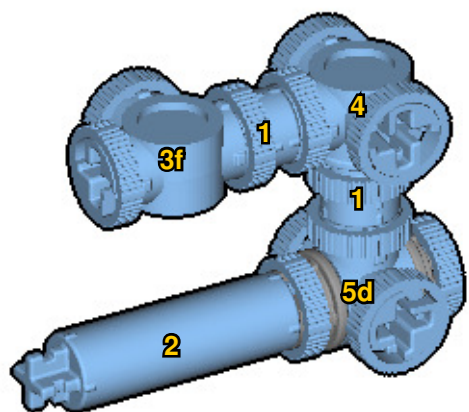

56

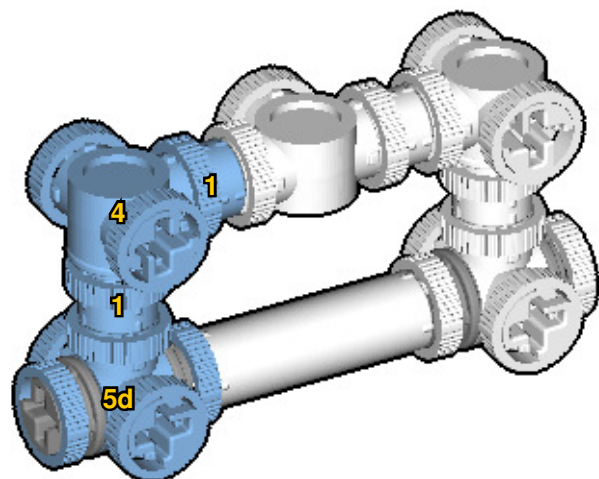

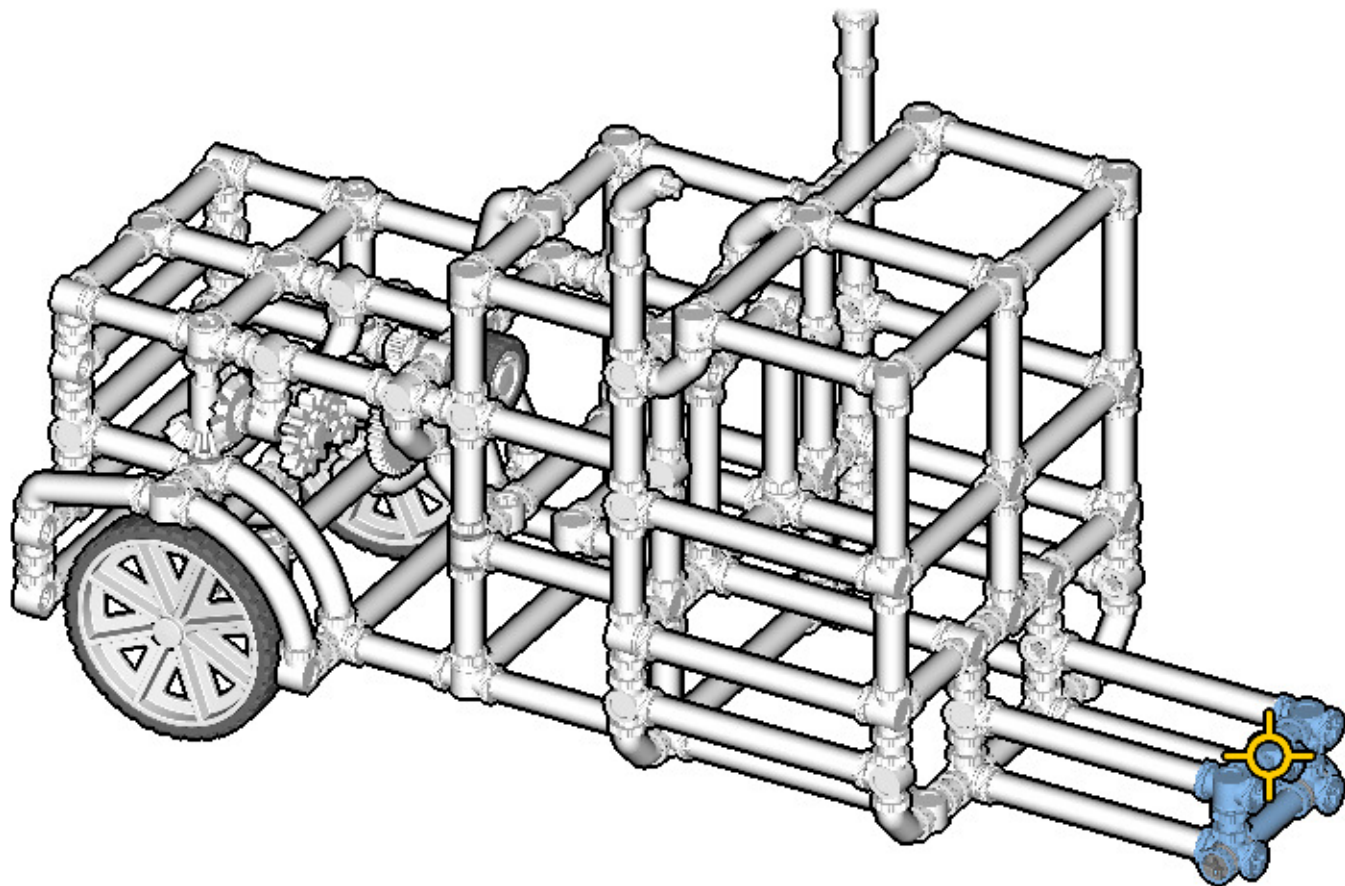

✦ : The next frame is centered on this piece.

58

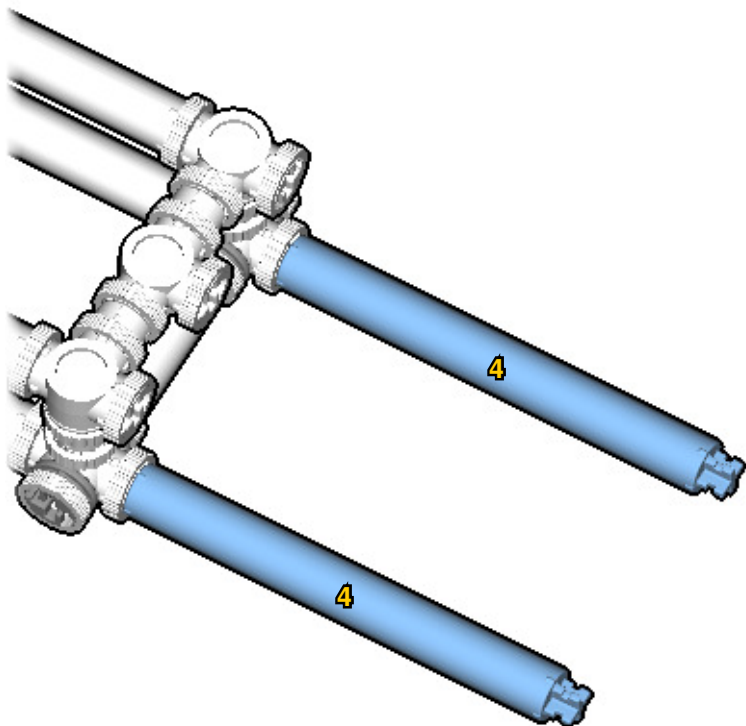

59

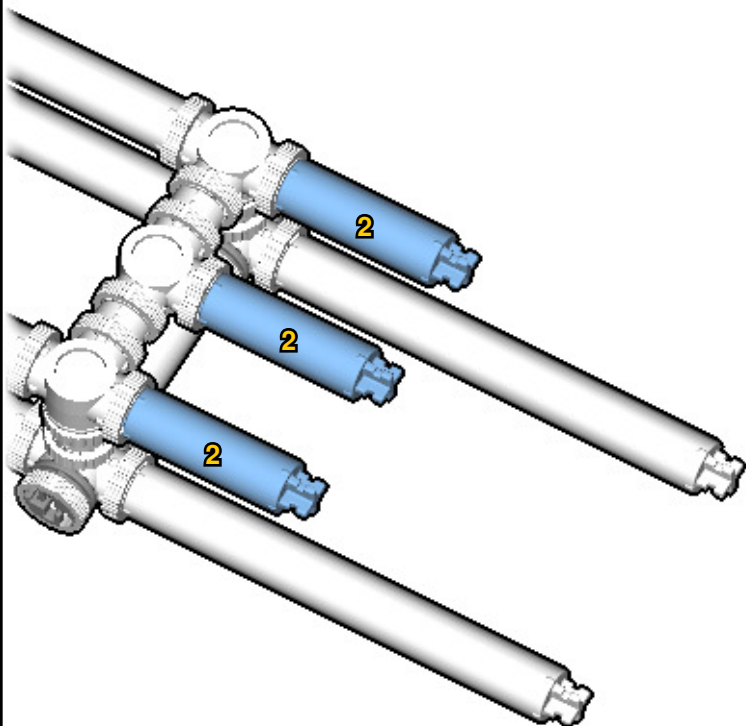

60

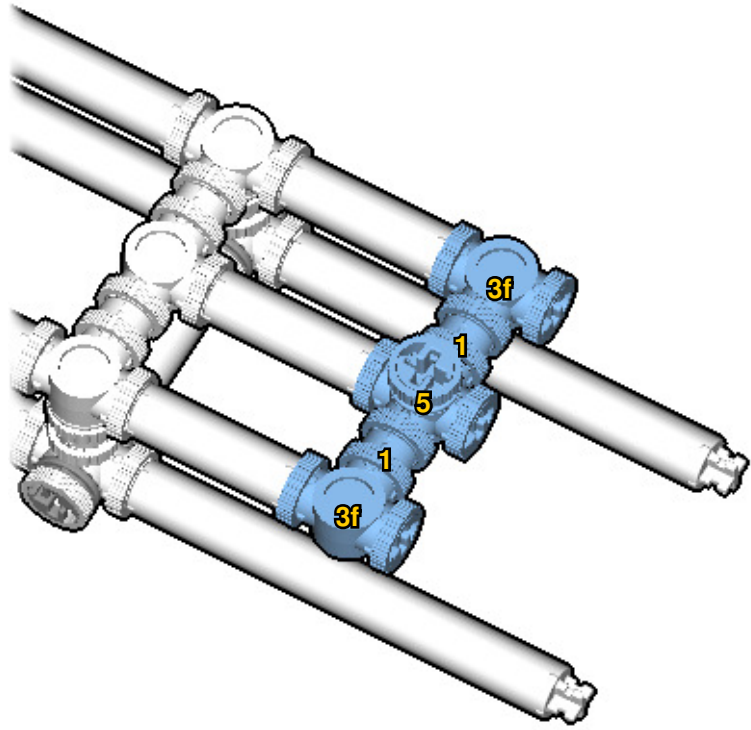

61

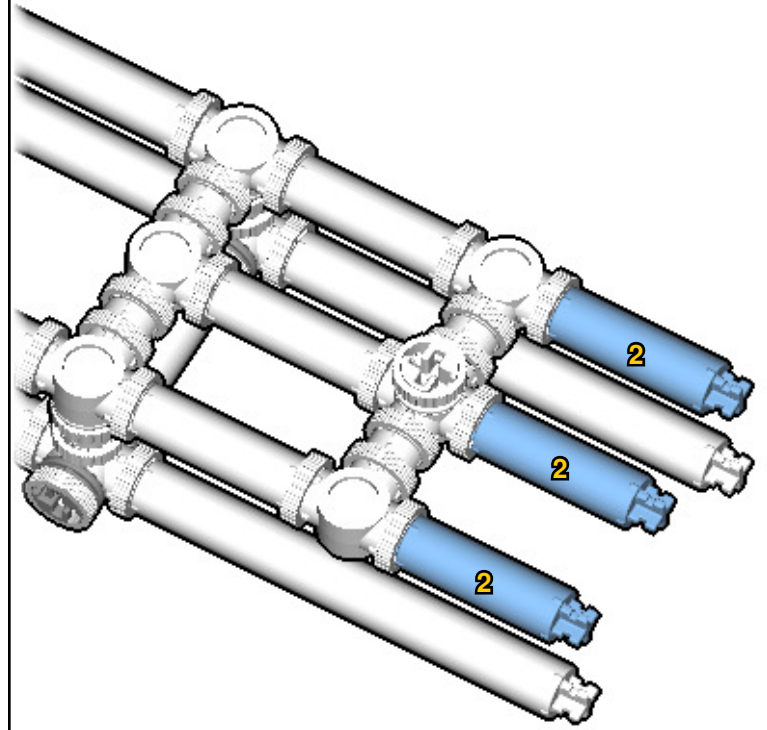

62

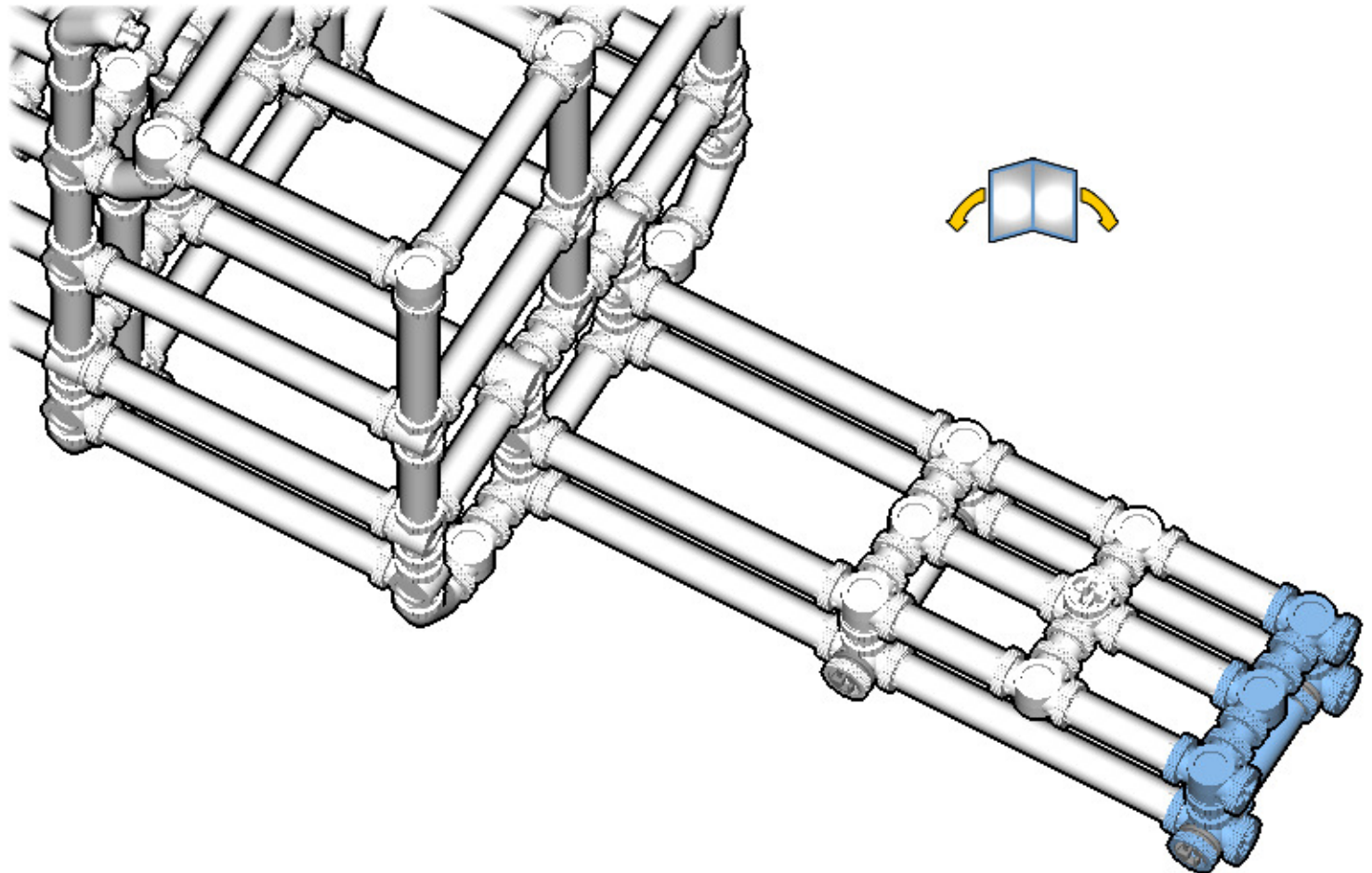

axle_w2 wheel2





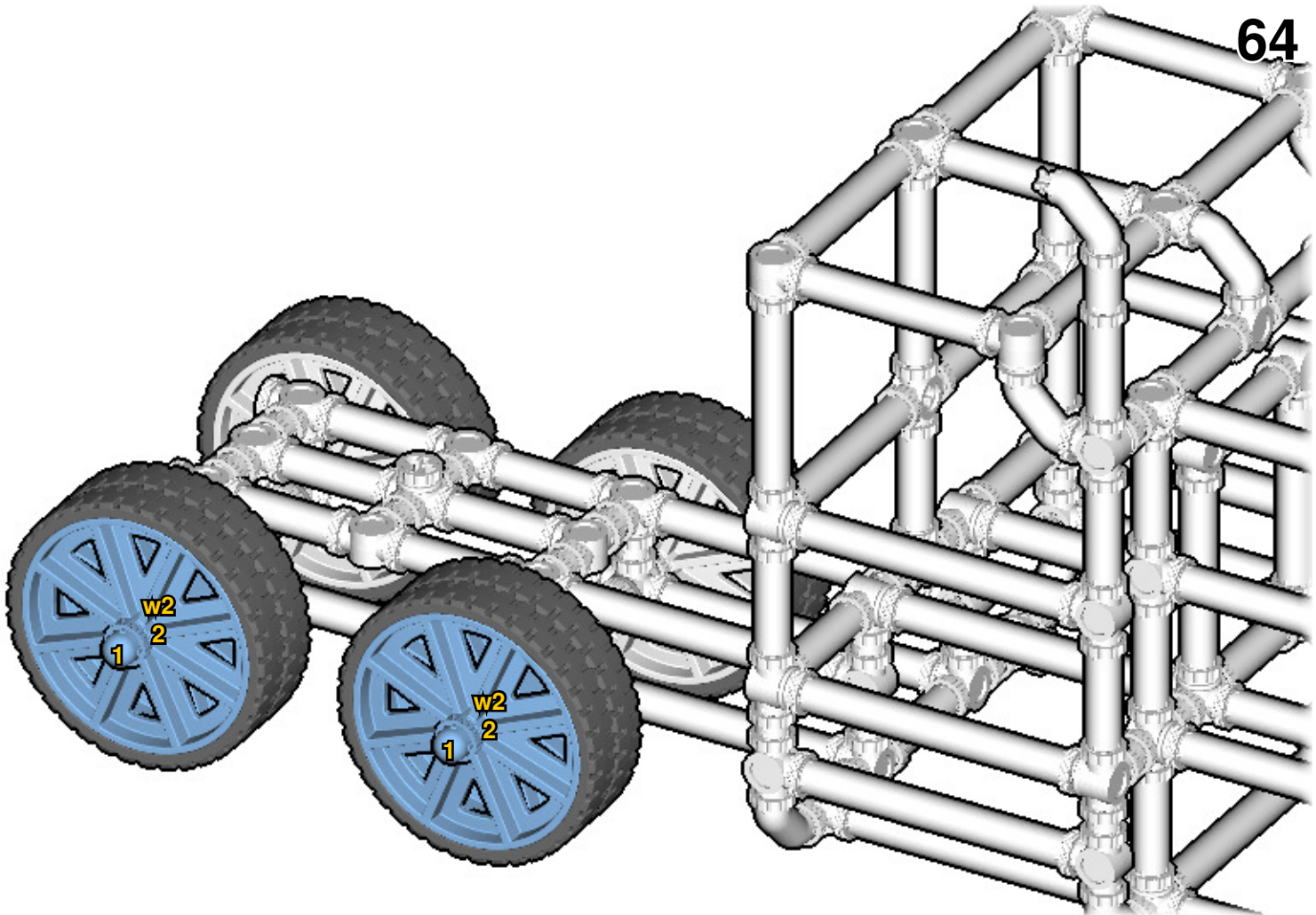
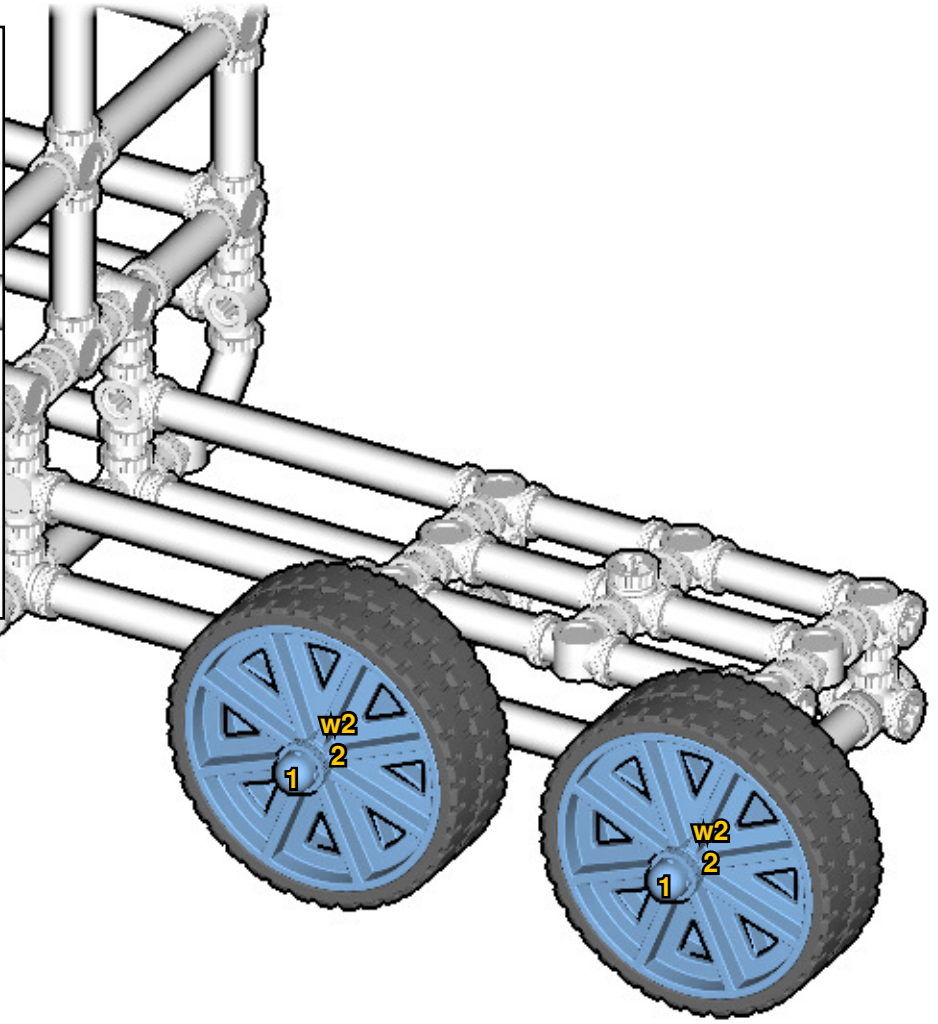

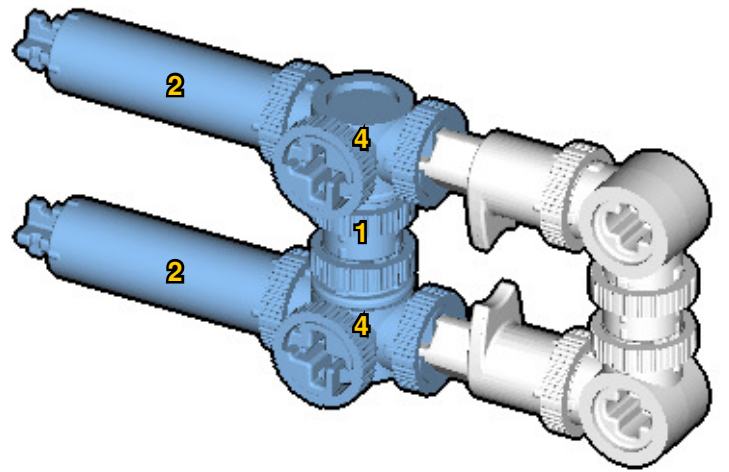
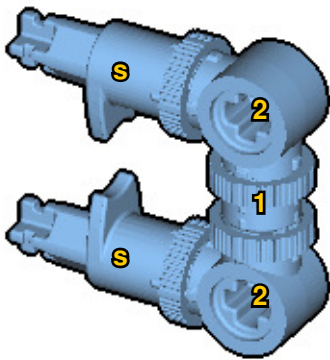
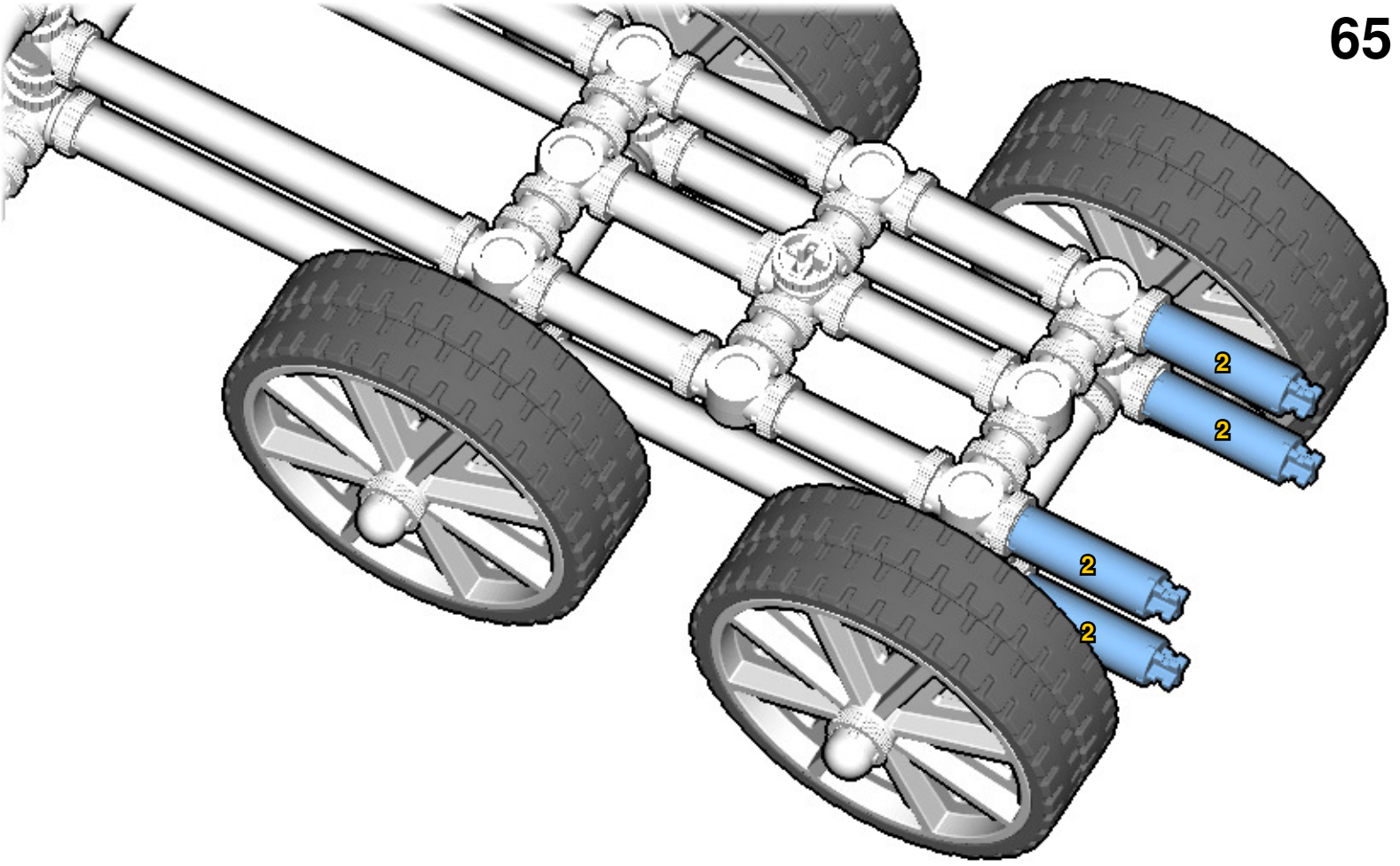

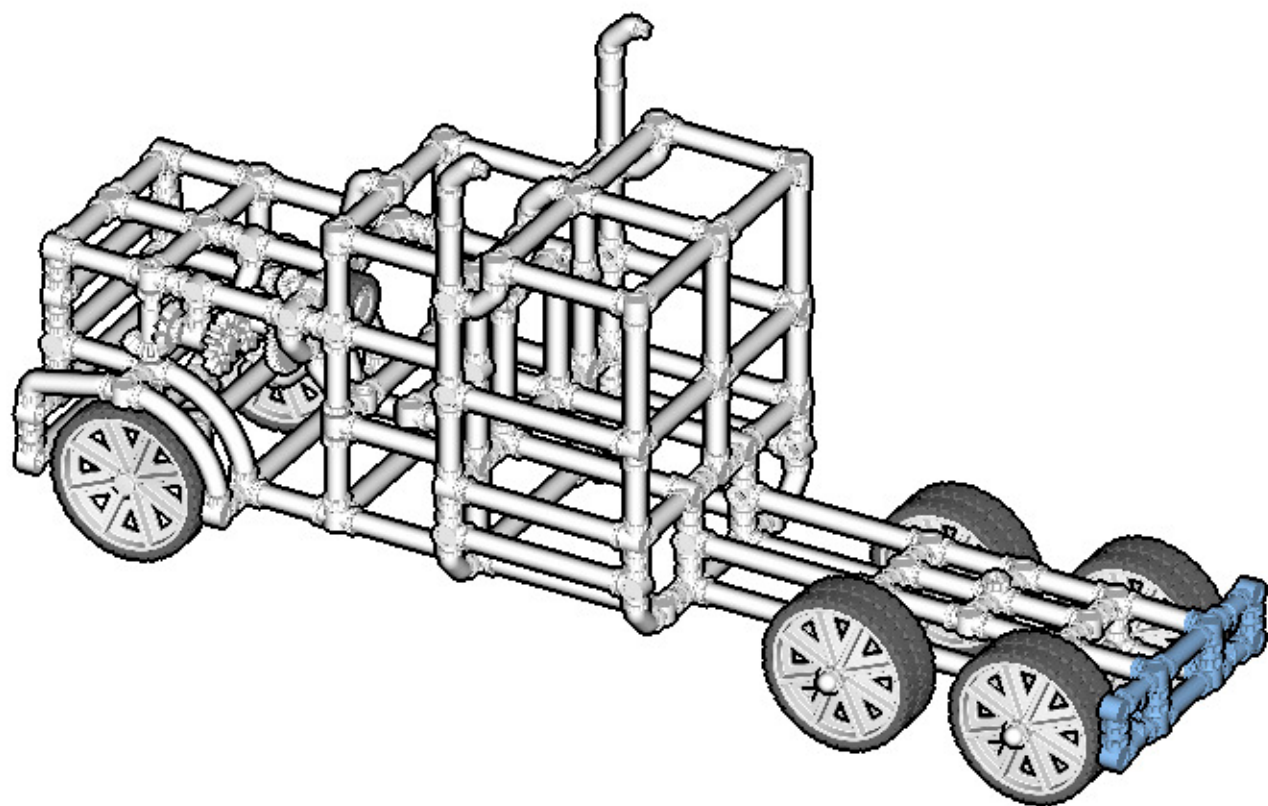
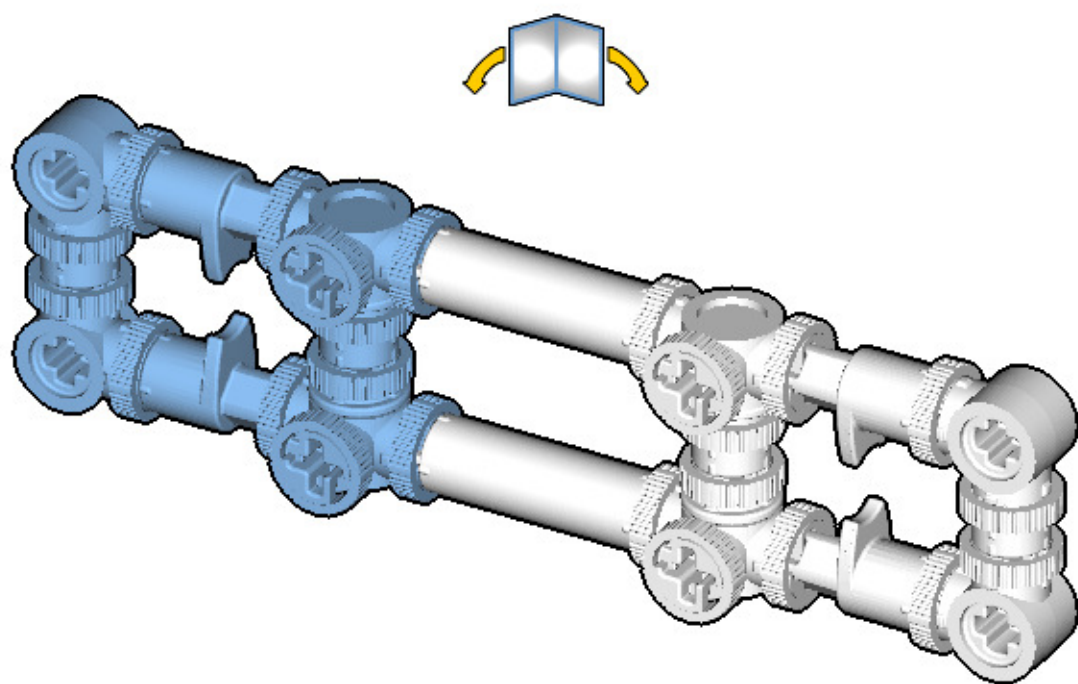



















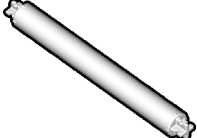





Slide axle_w2 through two wheel2s and join. Make hubs face joint.







INVENTORY

 15x angle1x1	 3x axle_w1	 4x join1	 5x join4f	 3x rotate4d	 64x straight2
 4x angle2x1	 4x axle_w2	 12x join2	 8x join5	 1x rotate4fd	 26x straight3
 4x arc2x2	 2x gear1	 2x join2f	 2x rotate2s	 2x rotate4s	 24x straight4
 3x axle_g1	 1x gear3l	 8x join3	 2x rotate3fd	 4x rotate5d	 1x wheel1
 2x axle_g2	 1x gear3s	 34x join3f	 1x rotate3fs	 3x rotate6d	 10x wheel2
 4x axle_s	 2x gear_b	 30x join4	 2x rotate3s	 59x straight1	

ACTUAL SIZE

