

SIZE	1.5ft x 0.6ft x 0.4ft	PIECES	419
DESIGNER	Charles Sharman	MADE IN	U.S.A.

SPORTS CAR

⚠ WARNING: Small parts. Age 14+. Not a toy. Handle responsibly. U.S. Patent 9,086,087.



Wrong
Connecting/Disconnecting Two Directions



Right
Connecting/Disconnecting One Direction

1

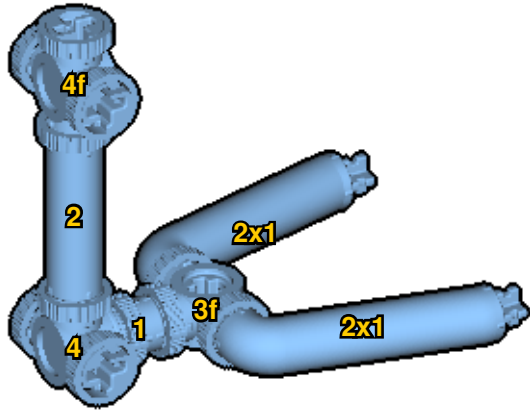

New pieces are drawn blue. Old pieces are drawn white.
See back for piece names.

2

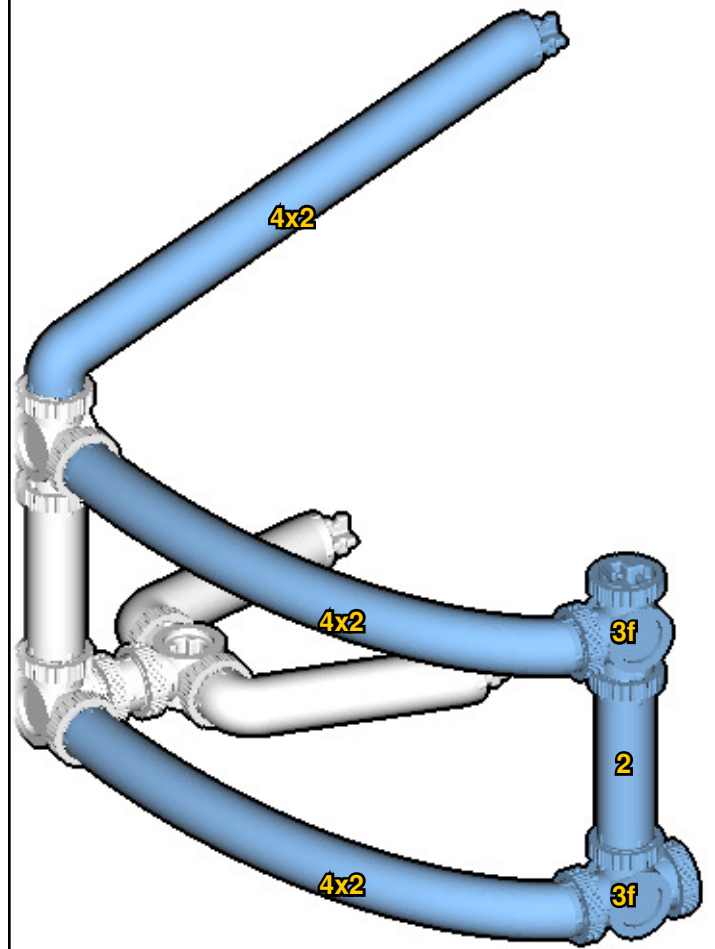

Connect new pieces together before connecting to old pieces.

3

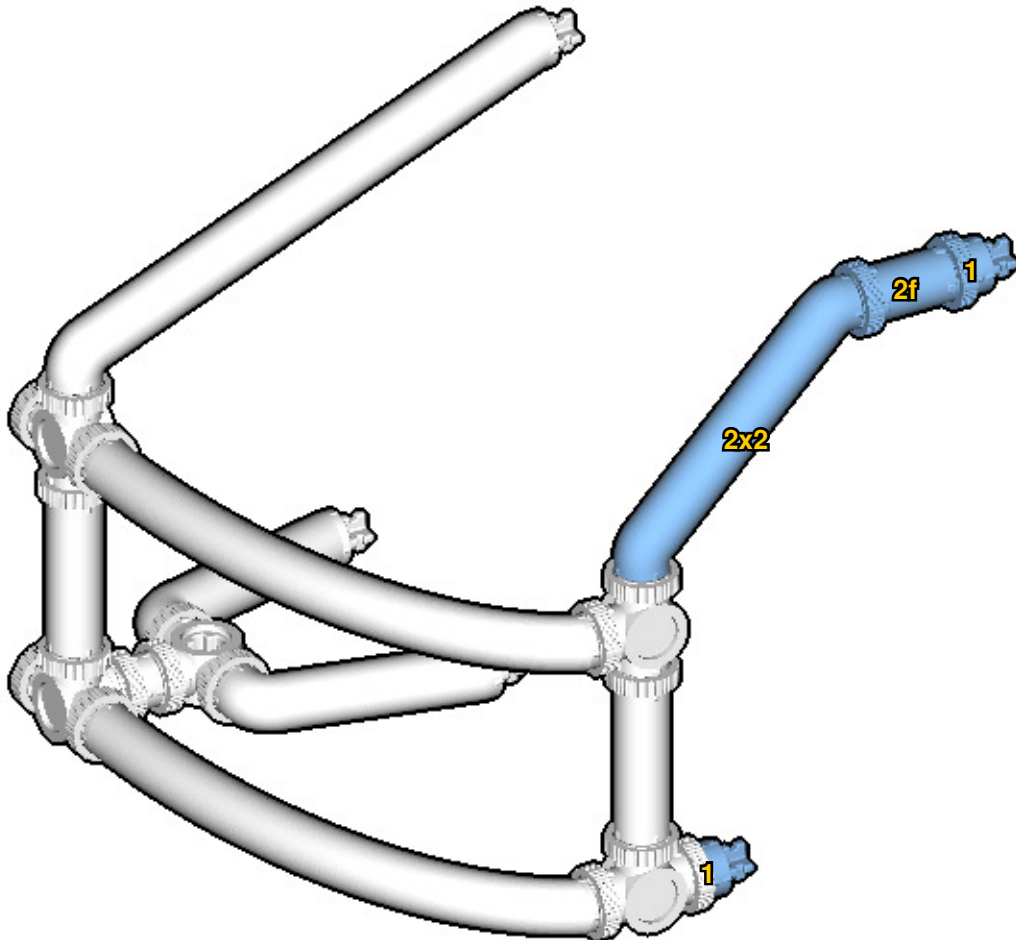

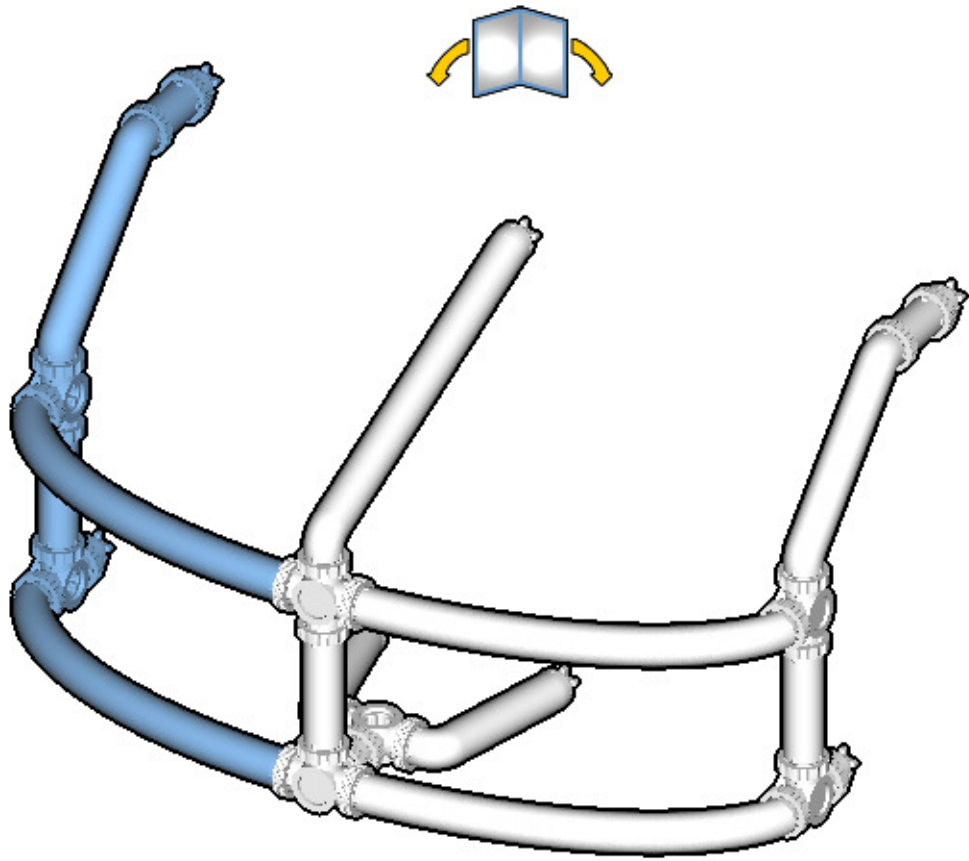

 : Copy new pieces from old pieces.

Submodel begins → **5**

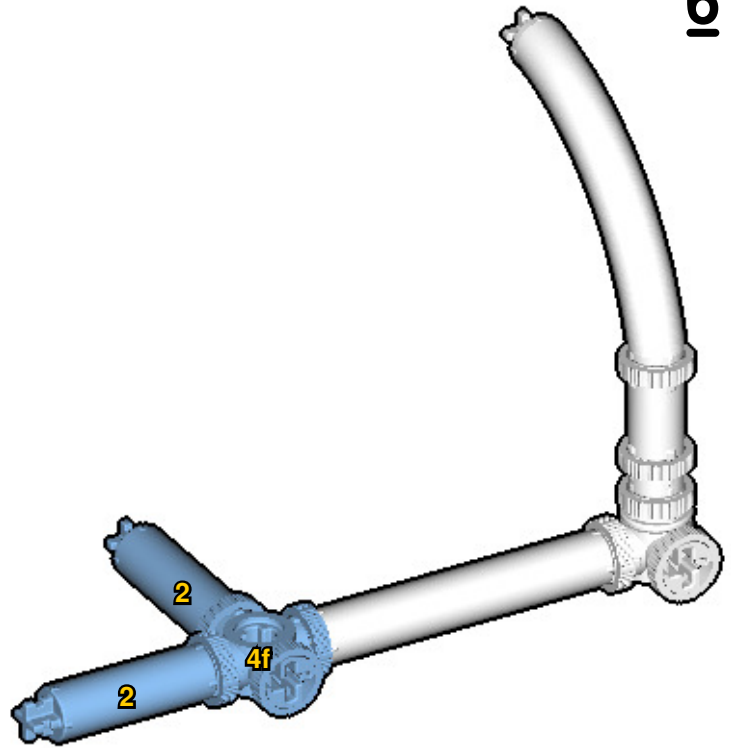
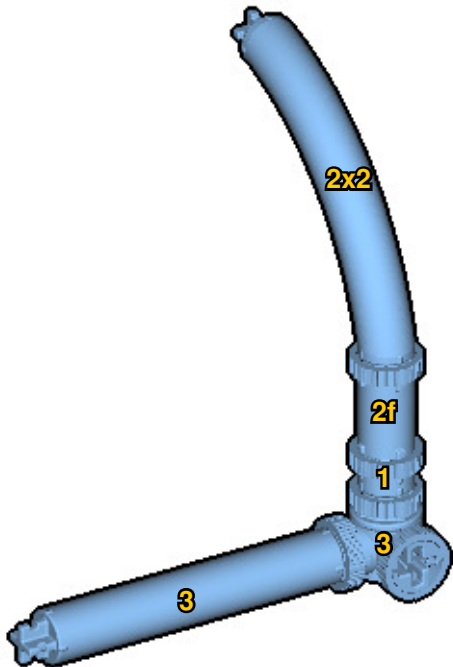

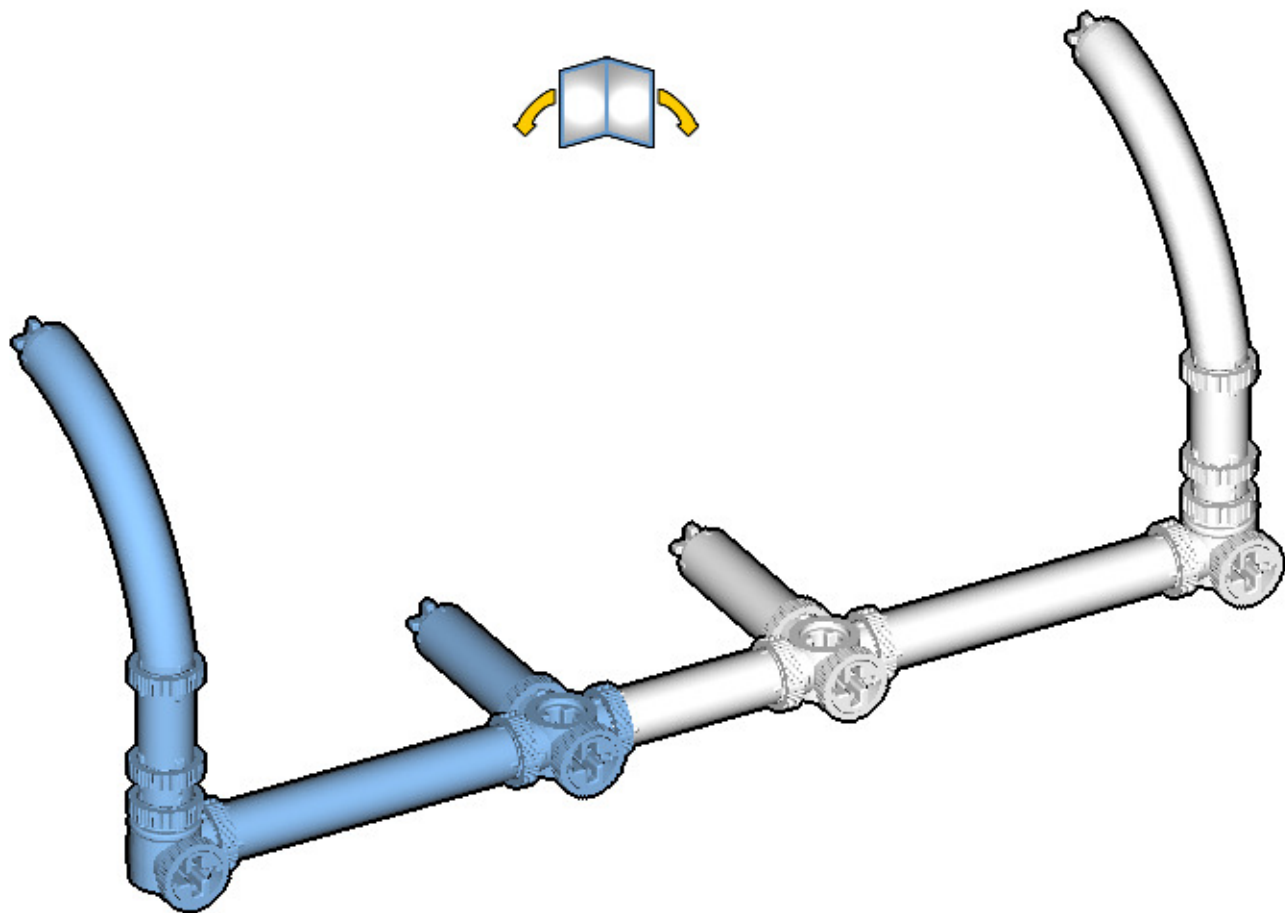

Submodel ends → **8**

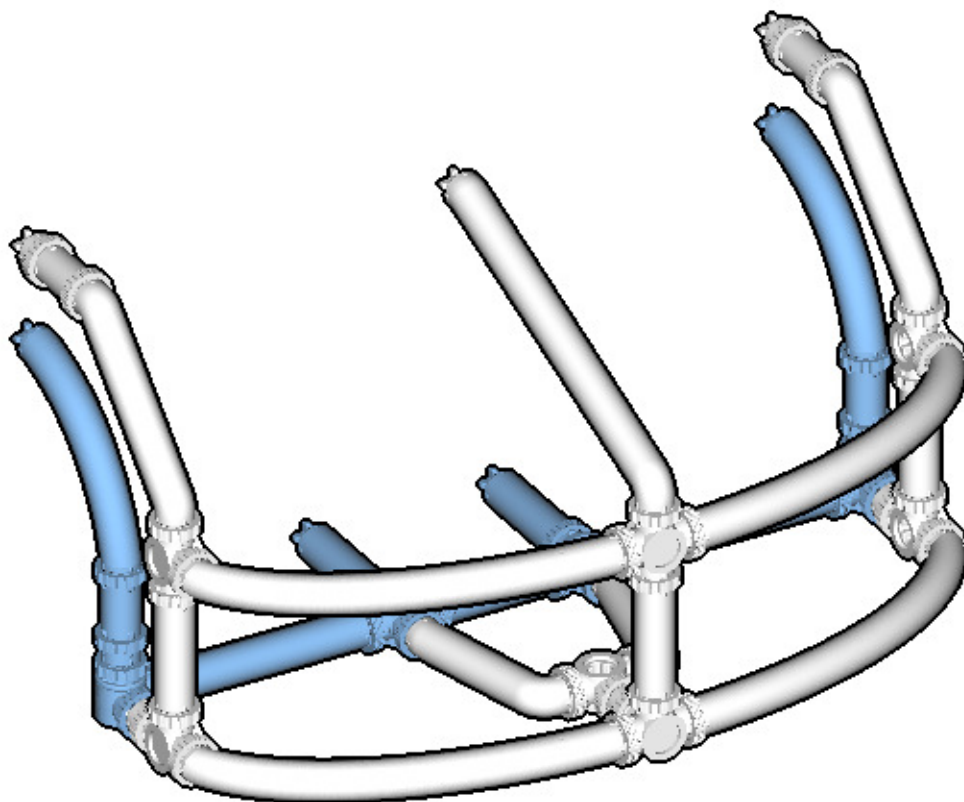

Connect submodel to model.

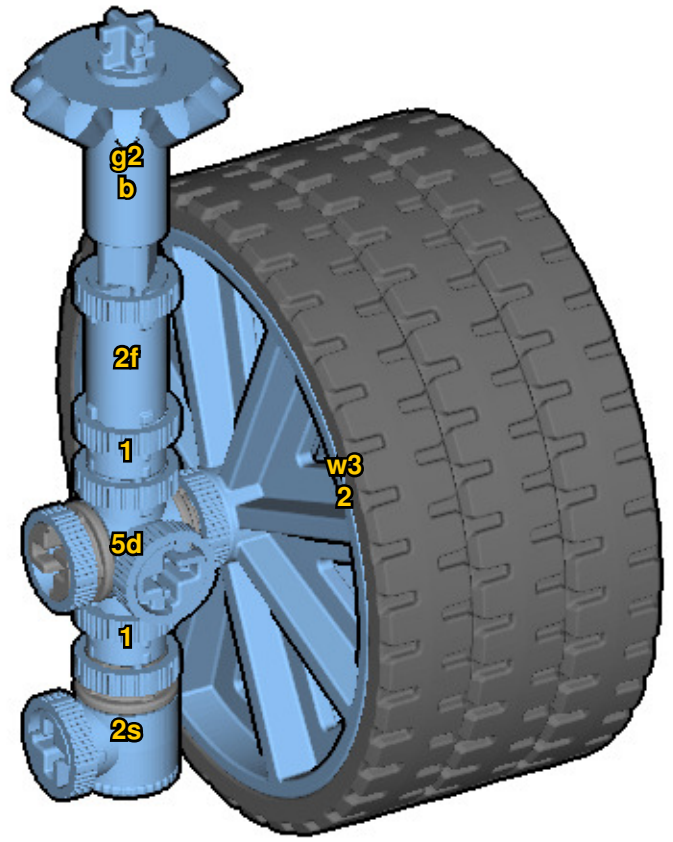
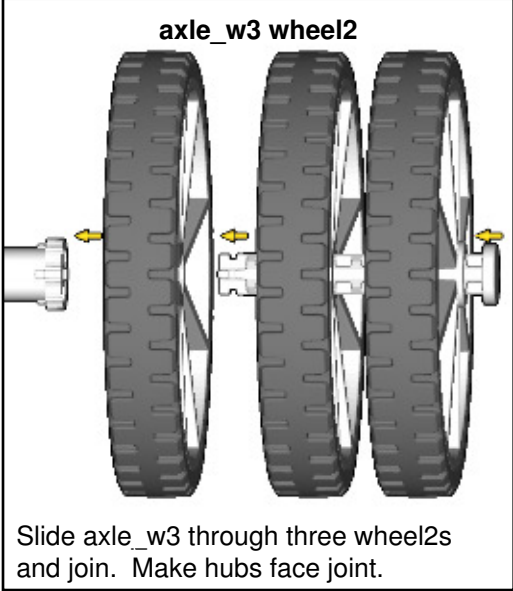
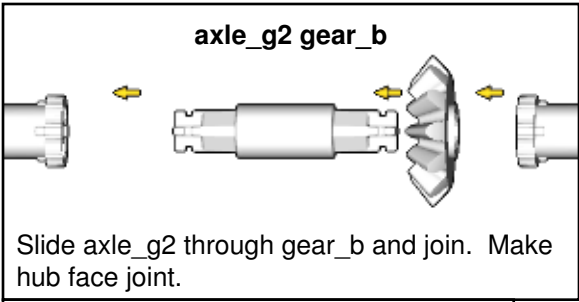

10

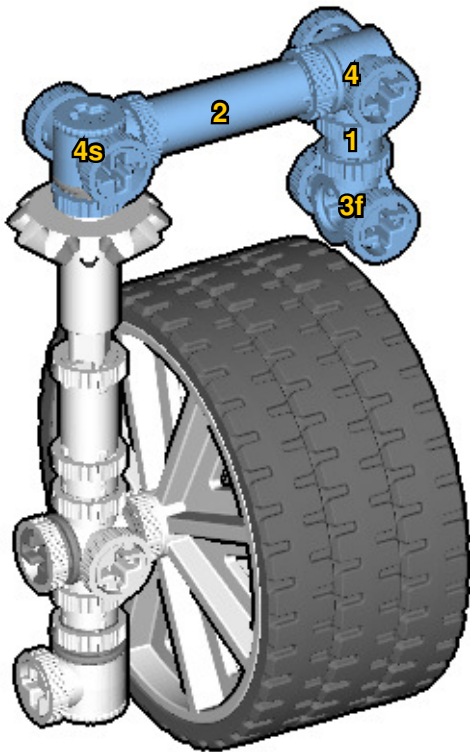

11

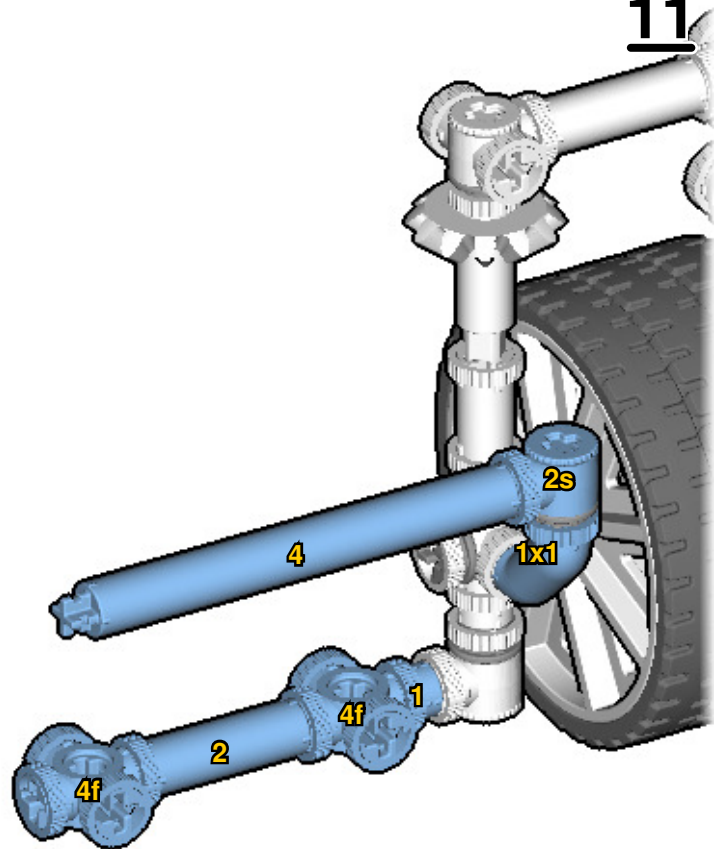

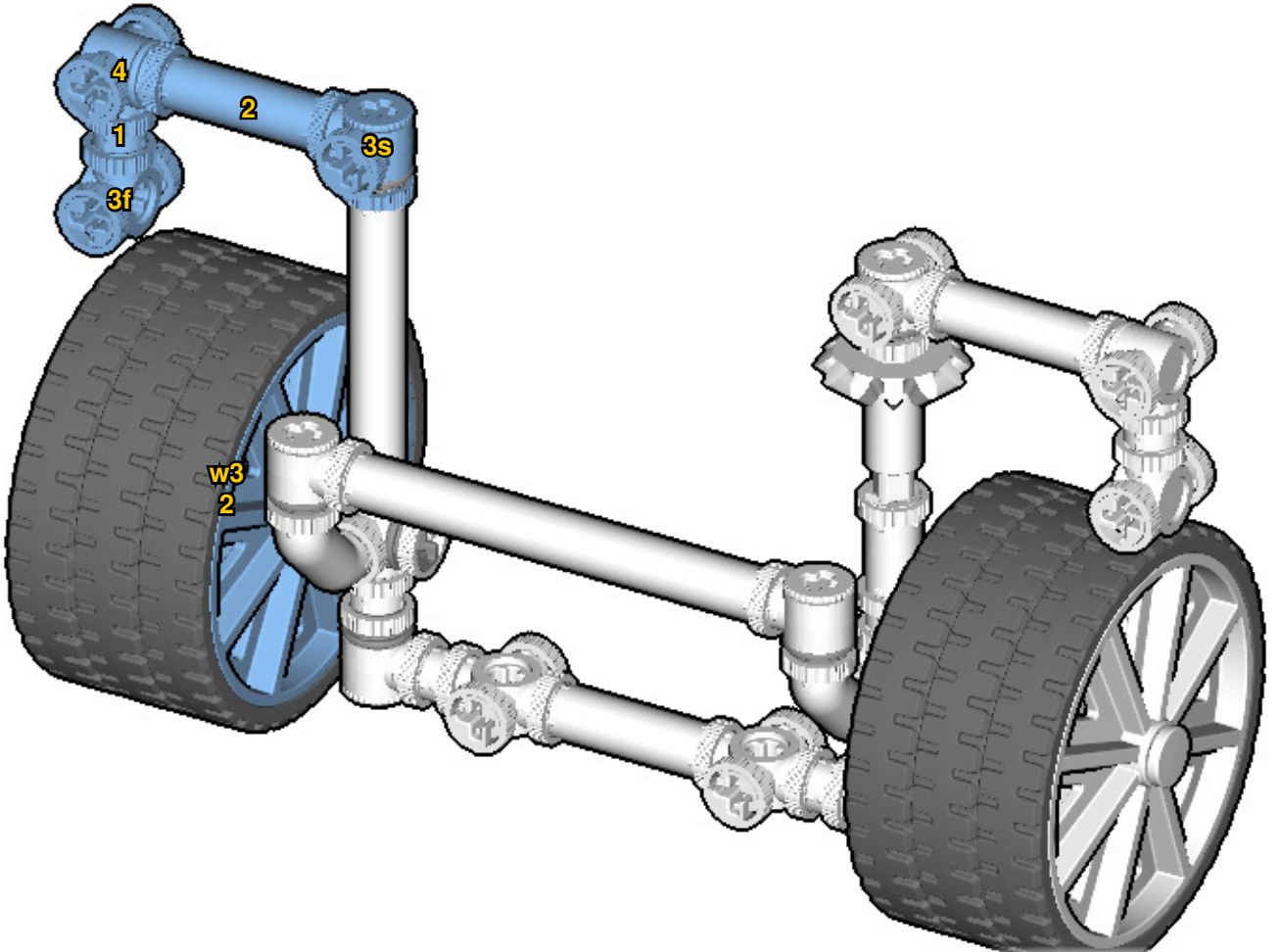
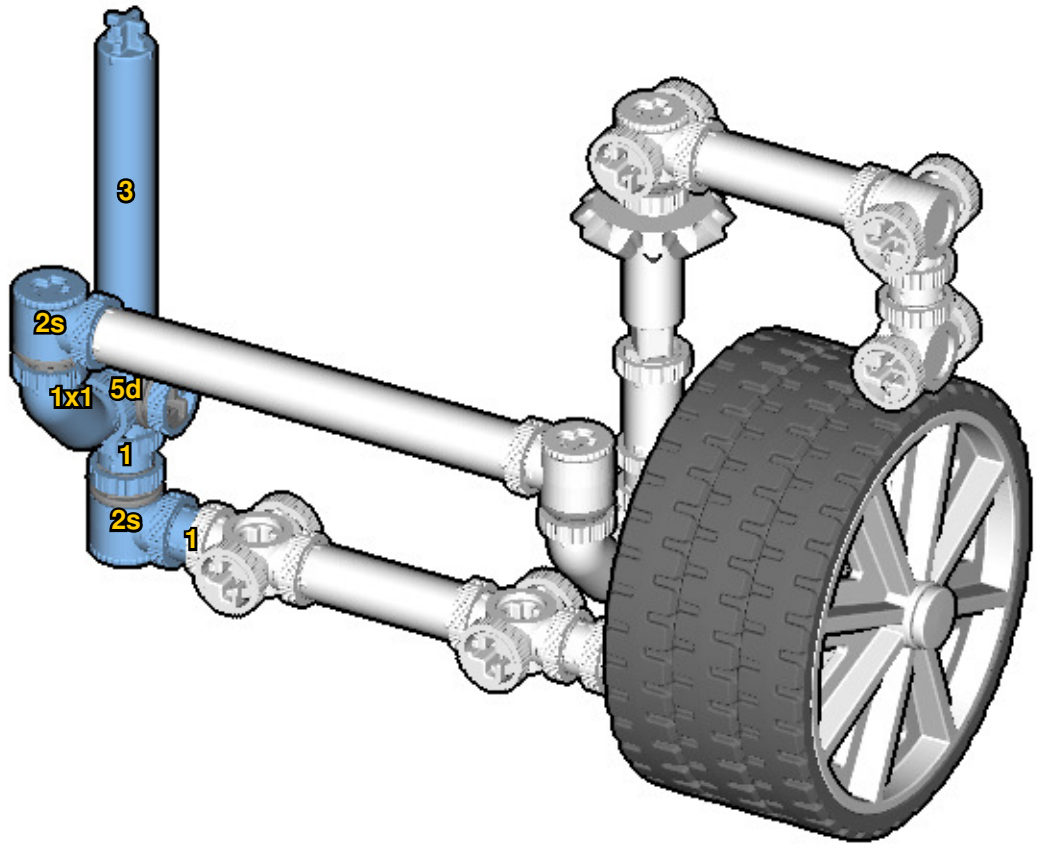

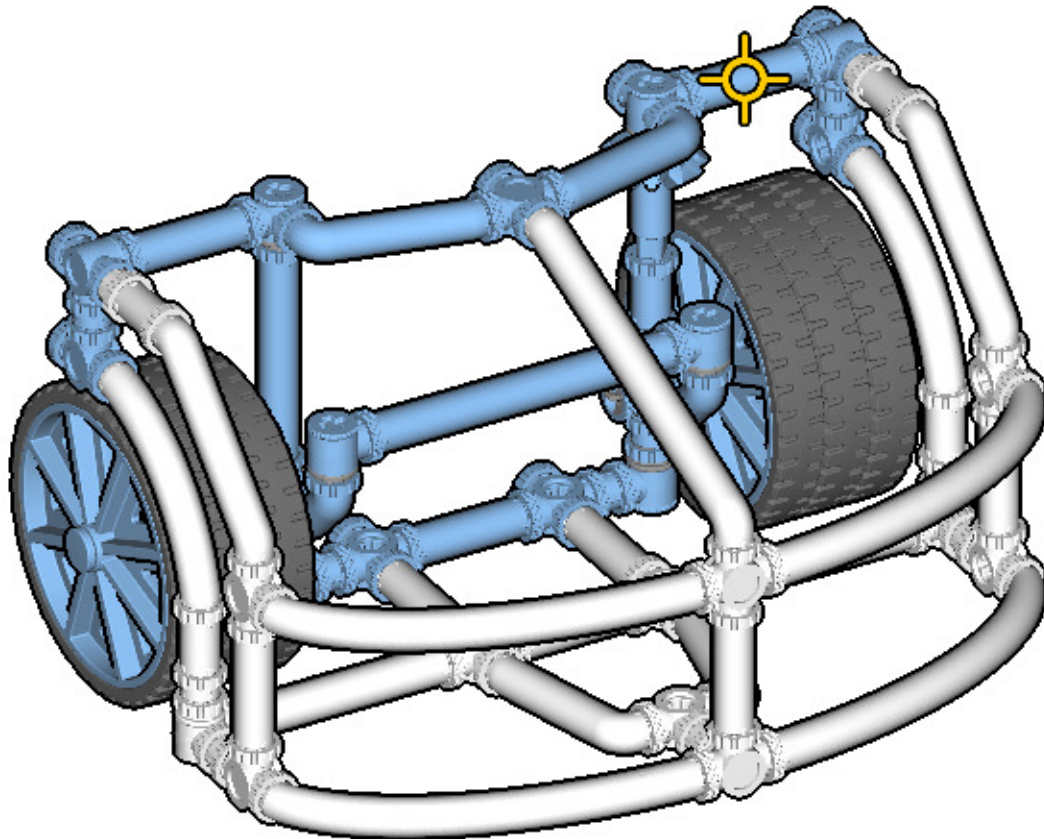
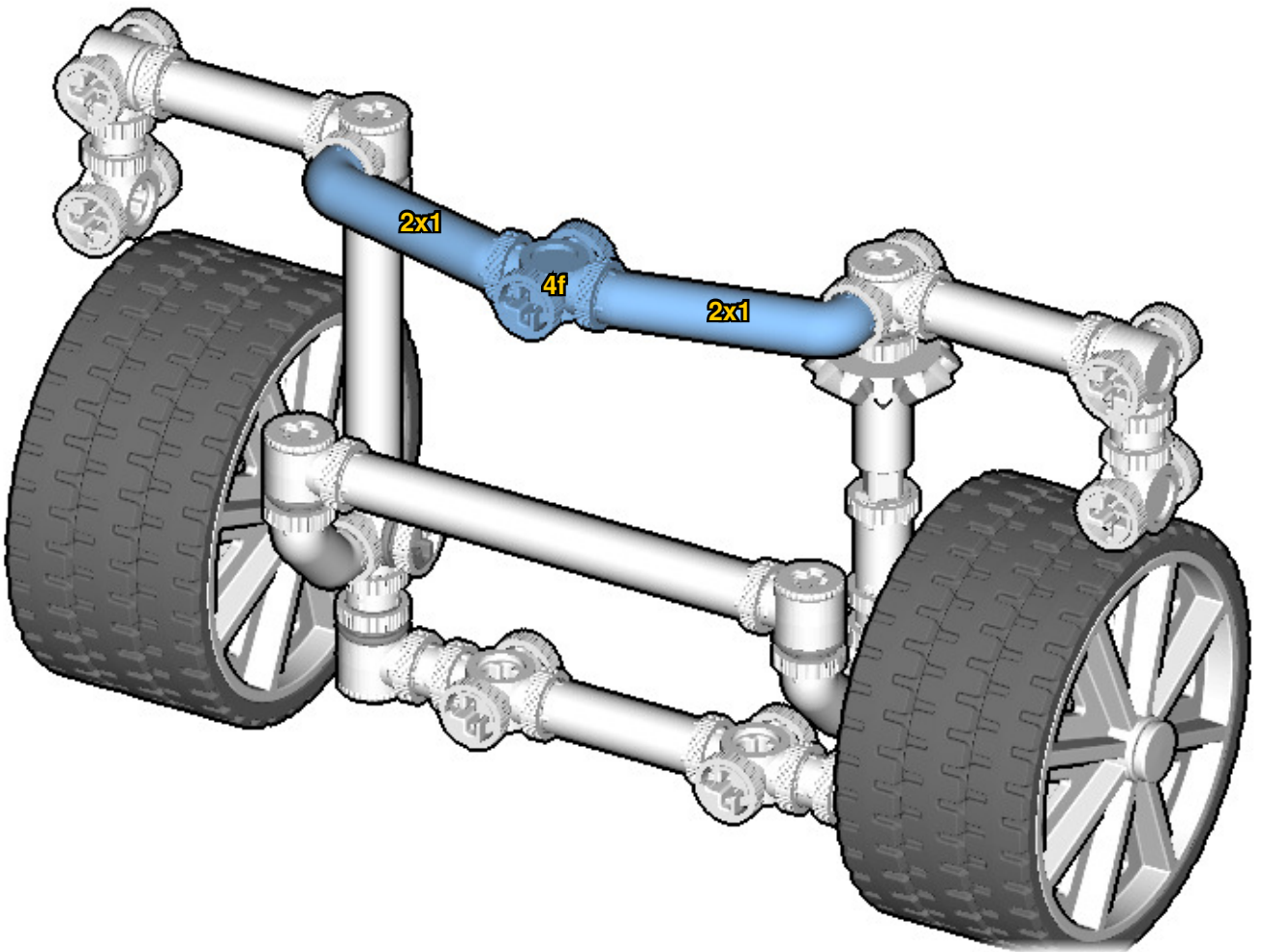

★ : The next frame is centered on this piece.

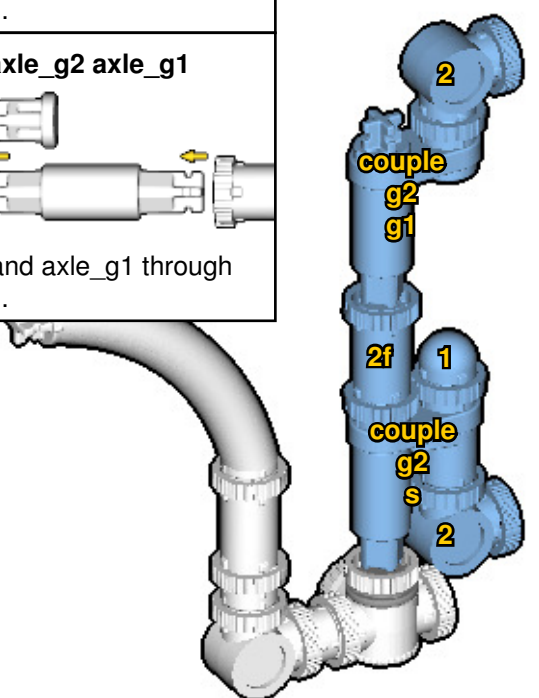
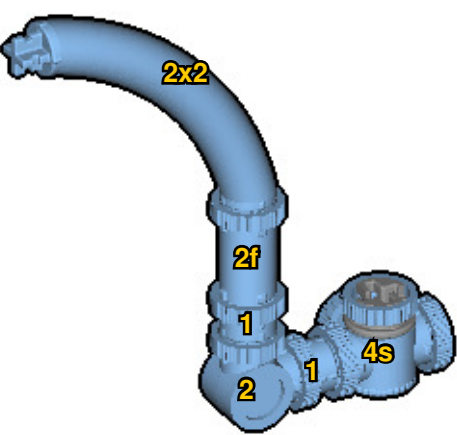
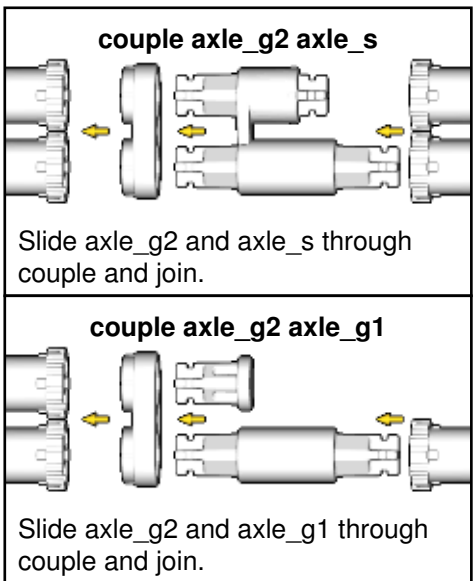
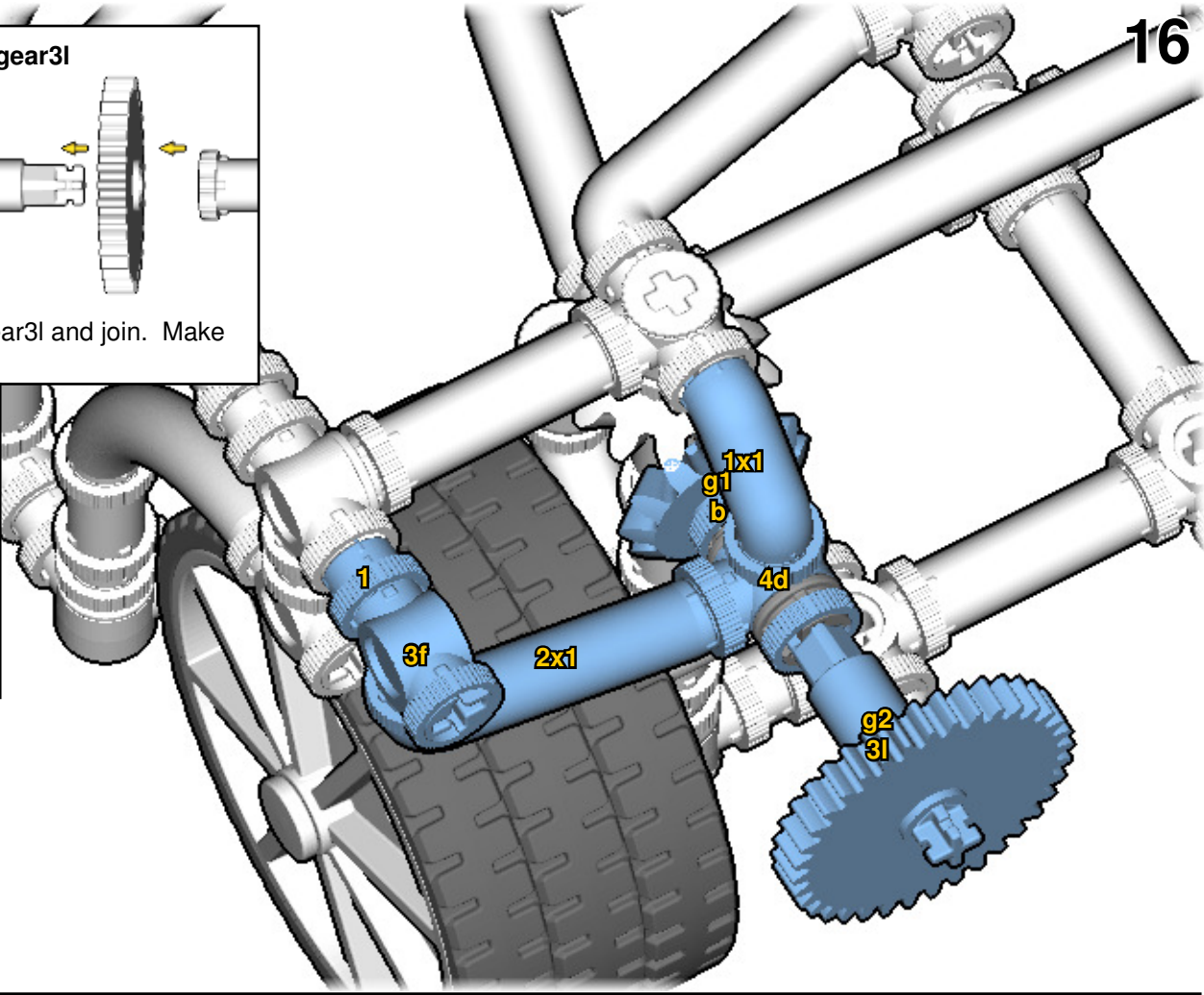
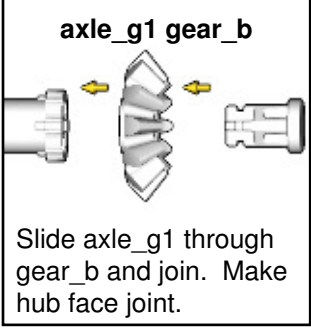
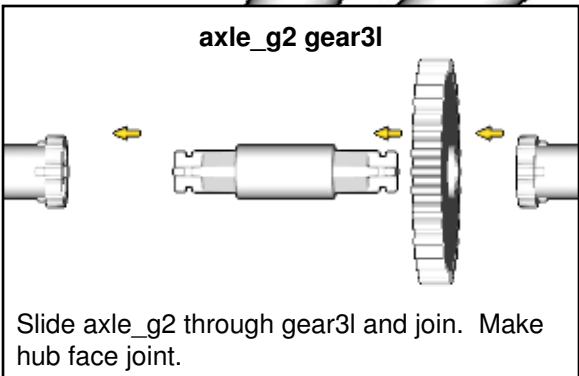

19

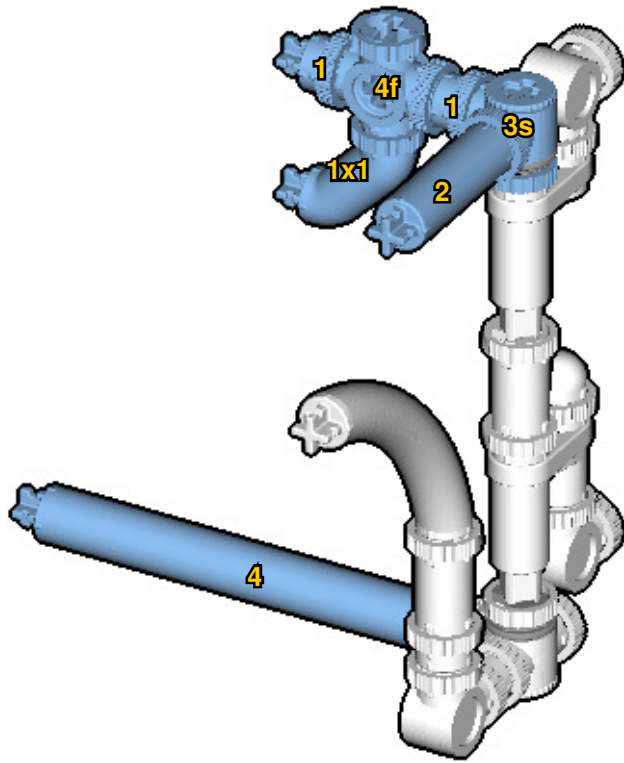

20

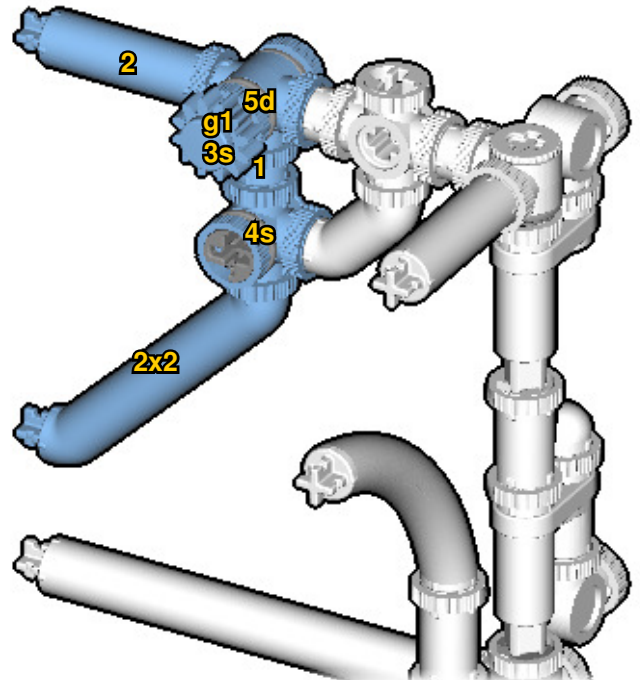
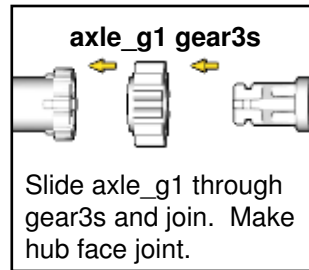

21

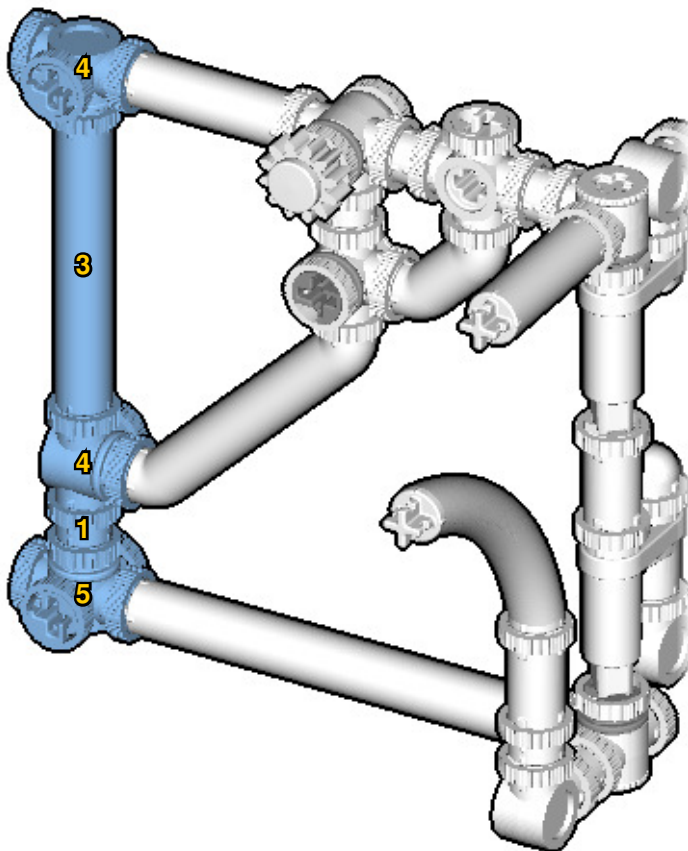

22

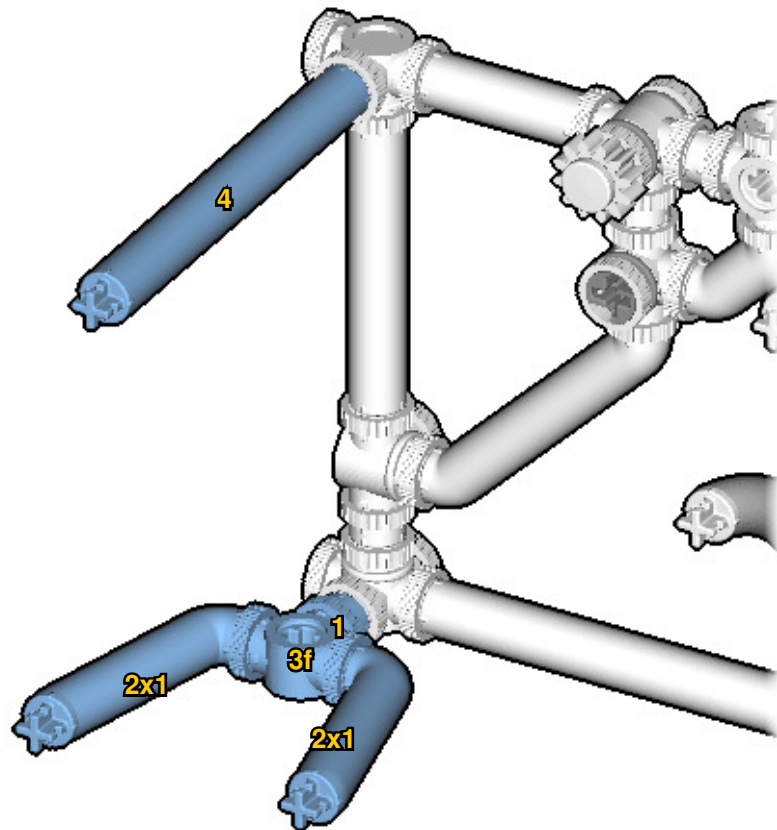

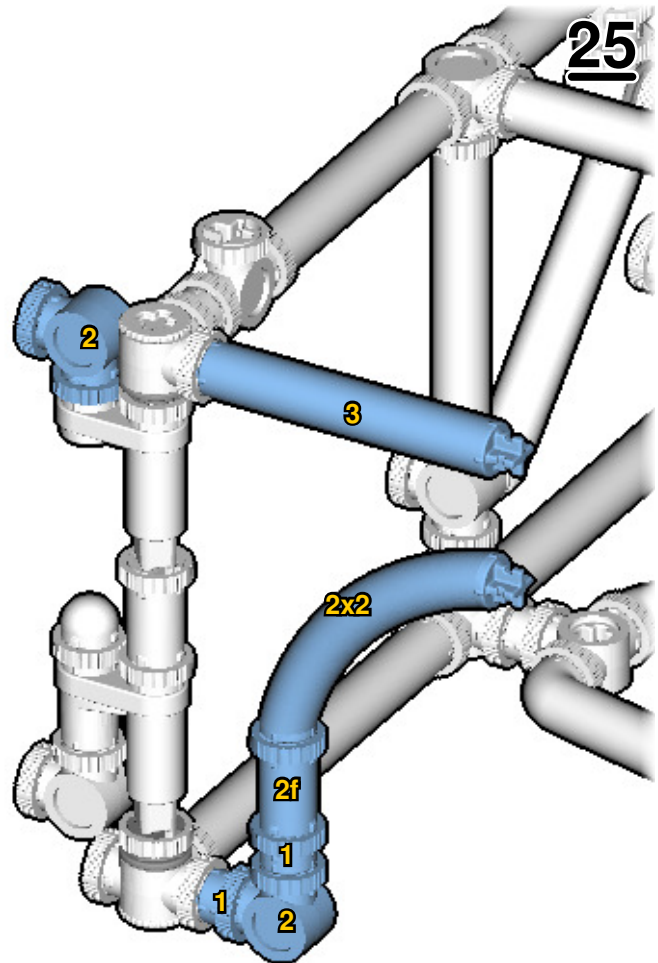
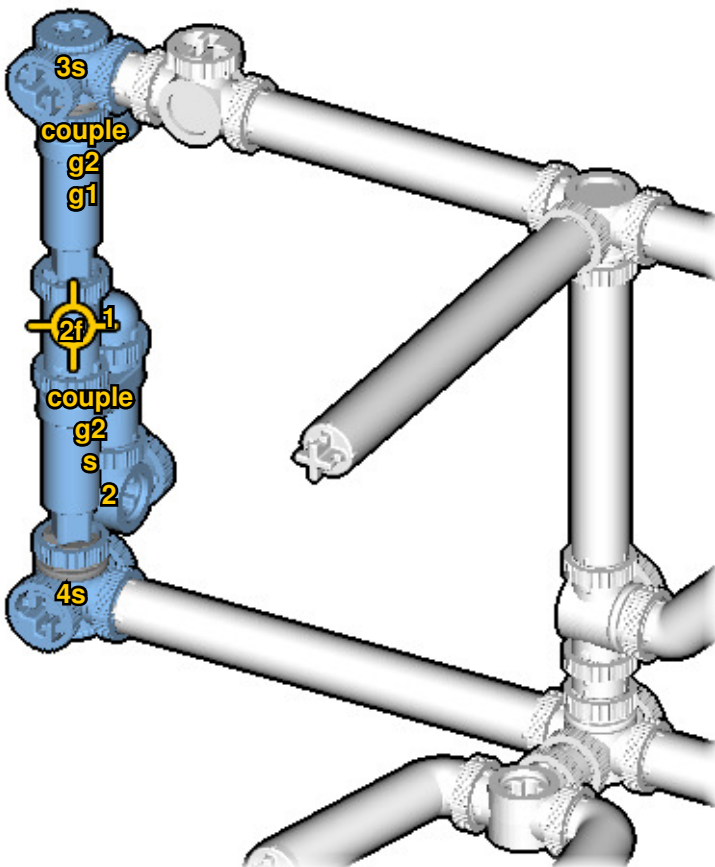
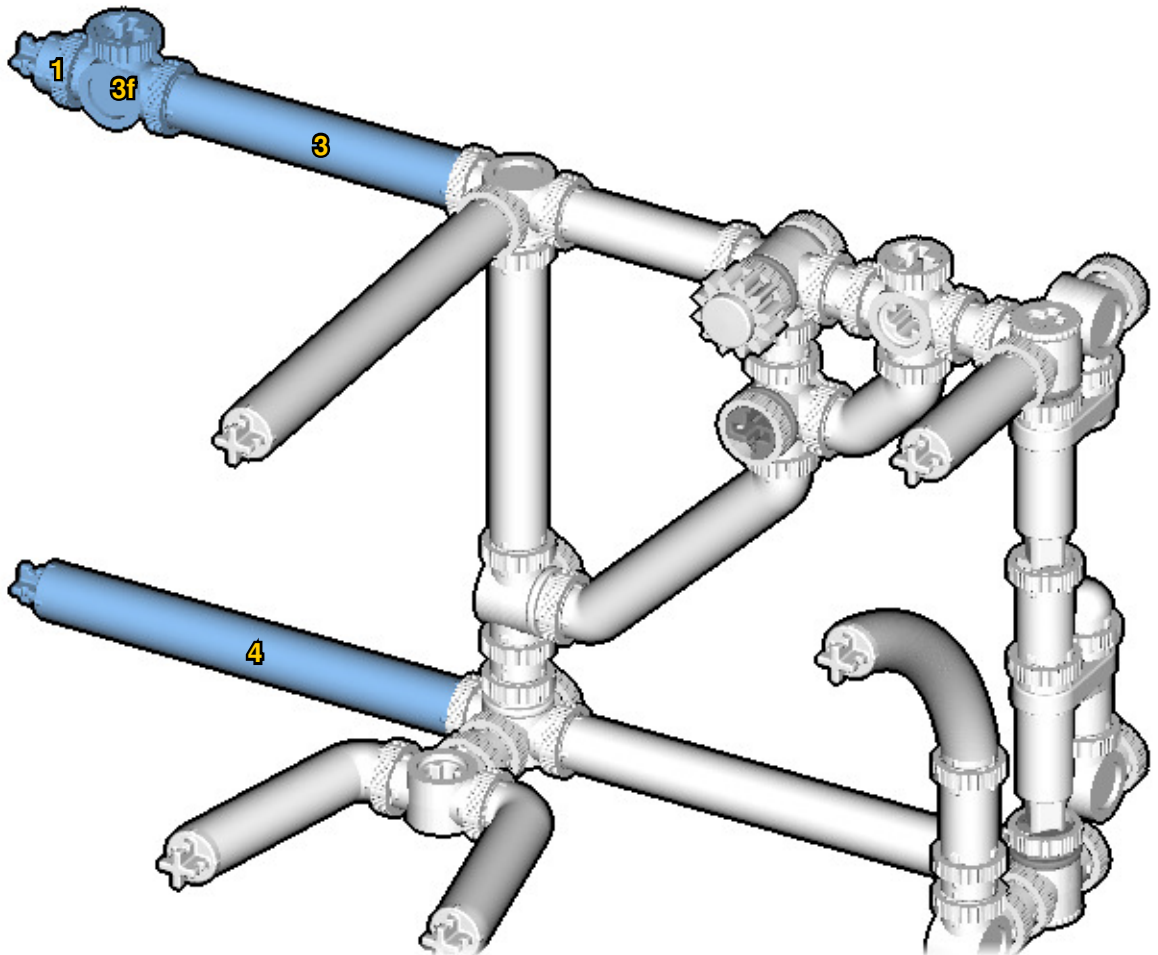

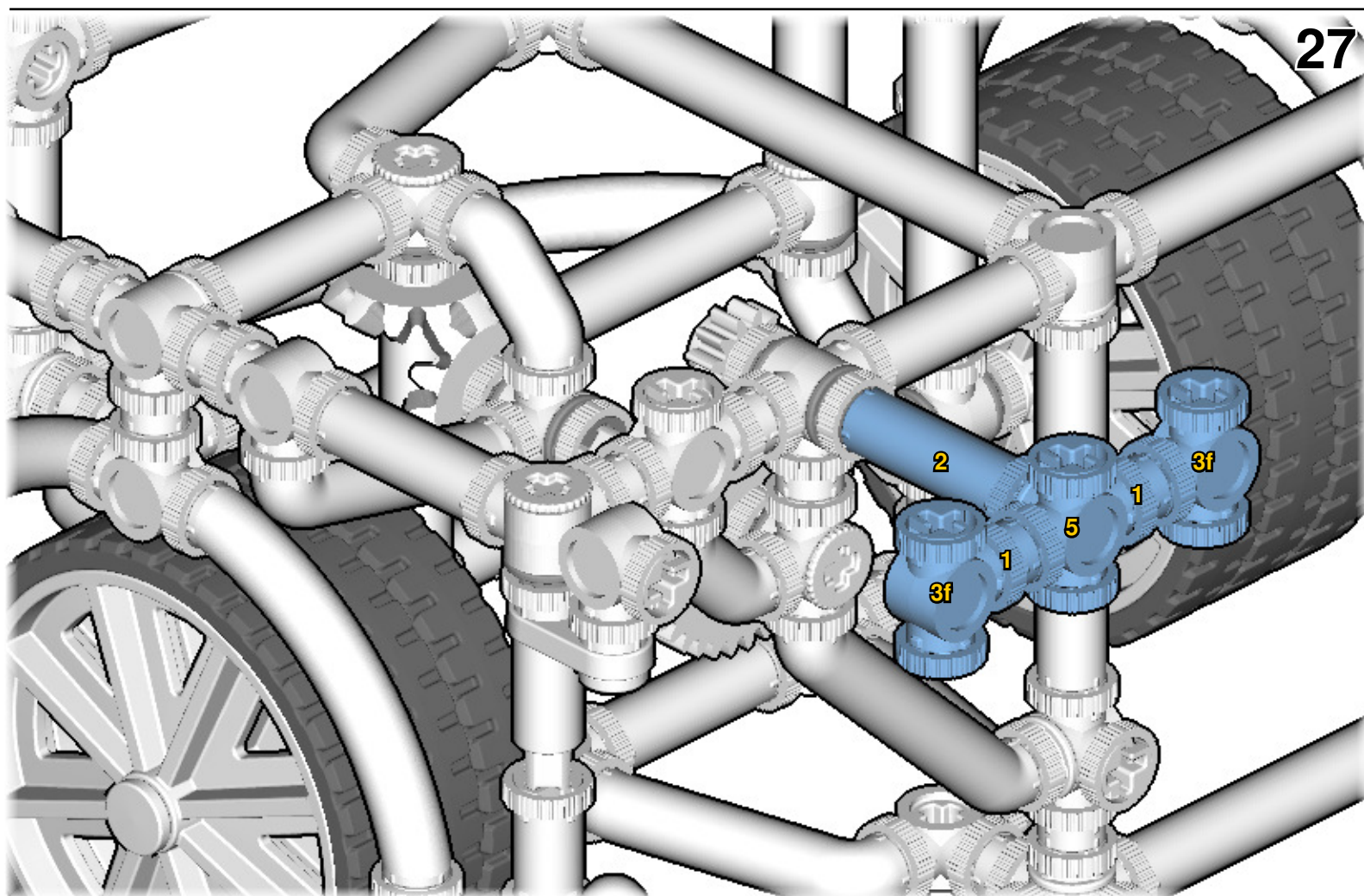
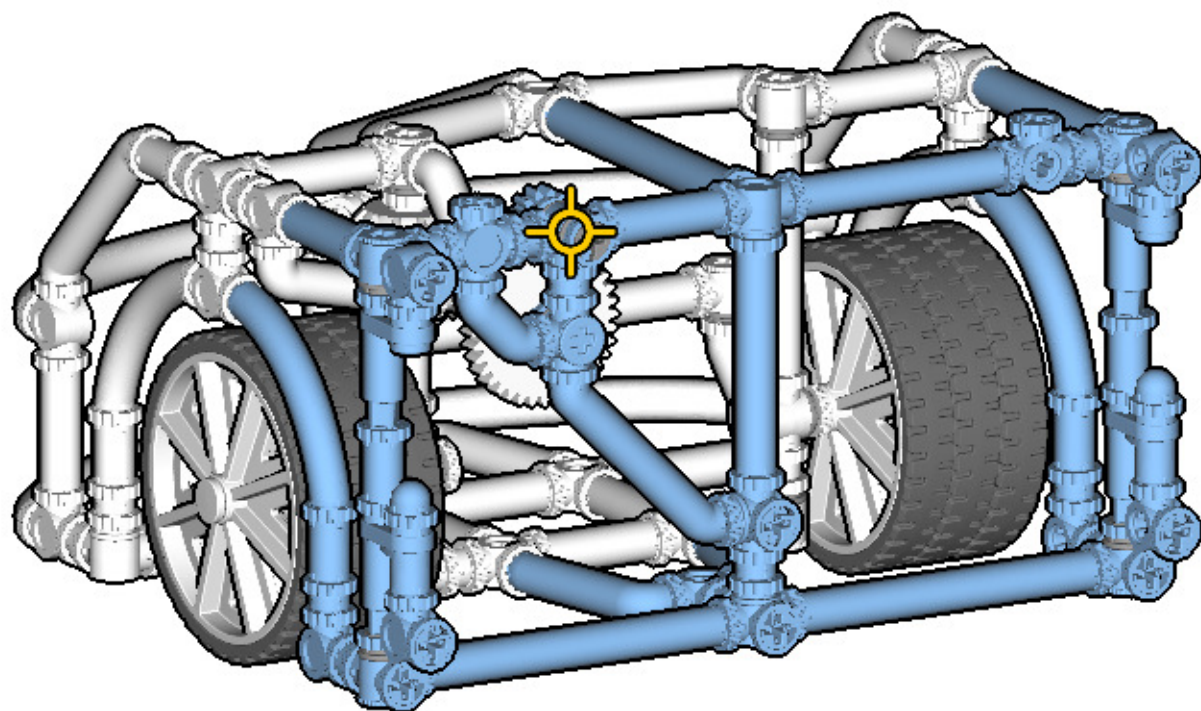

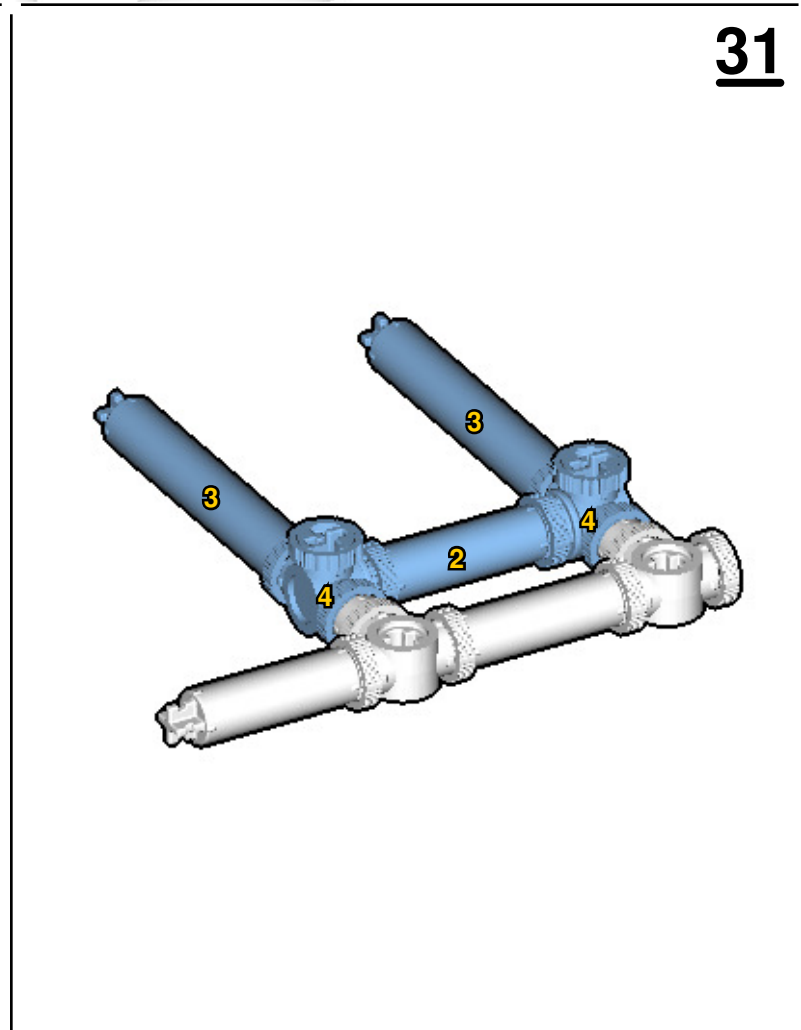
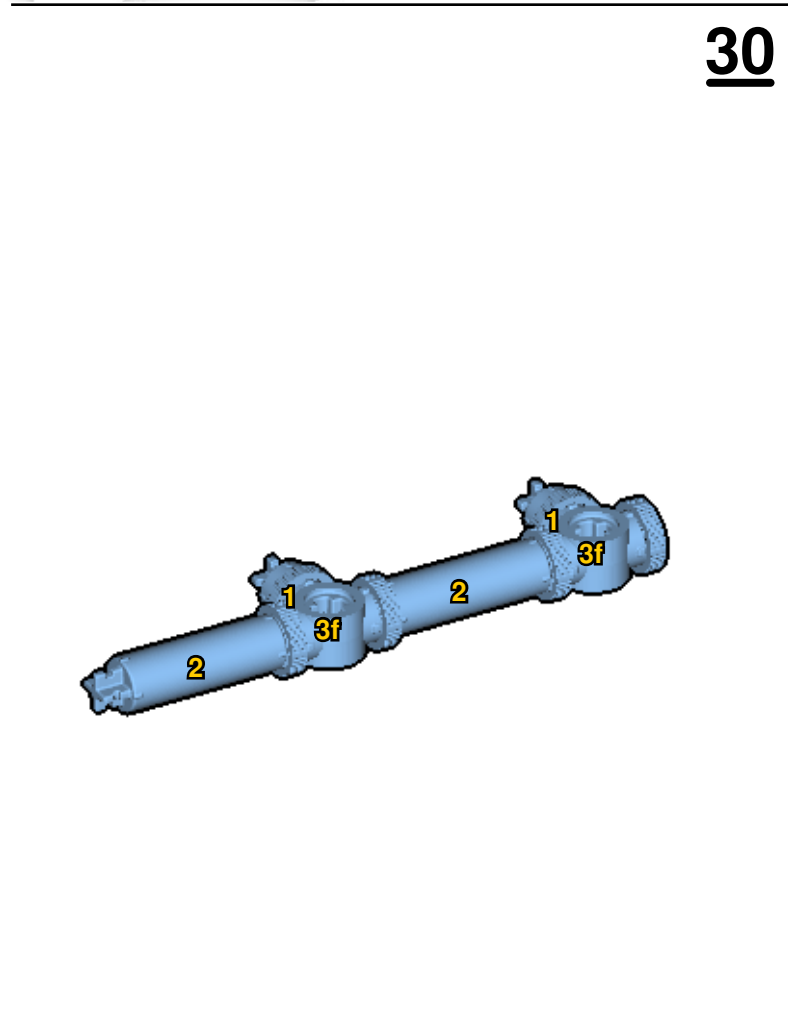
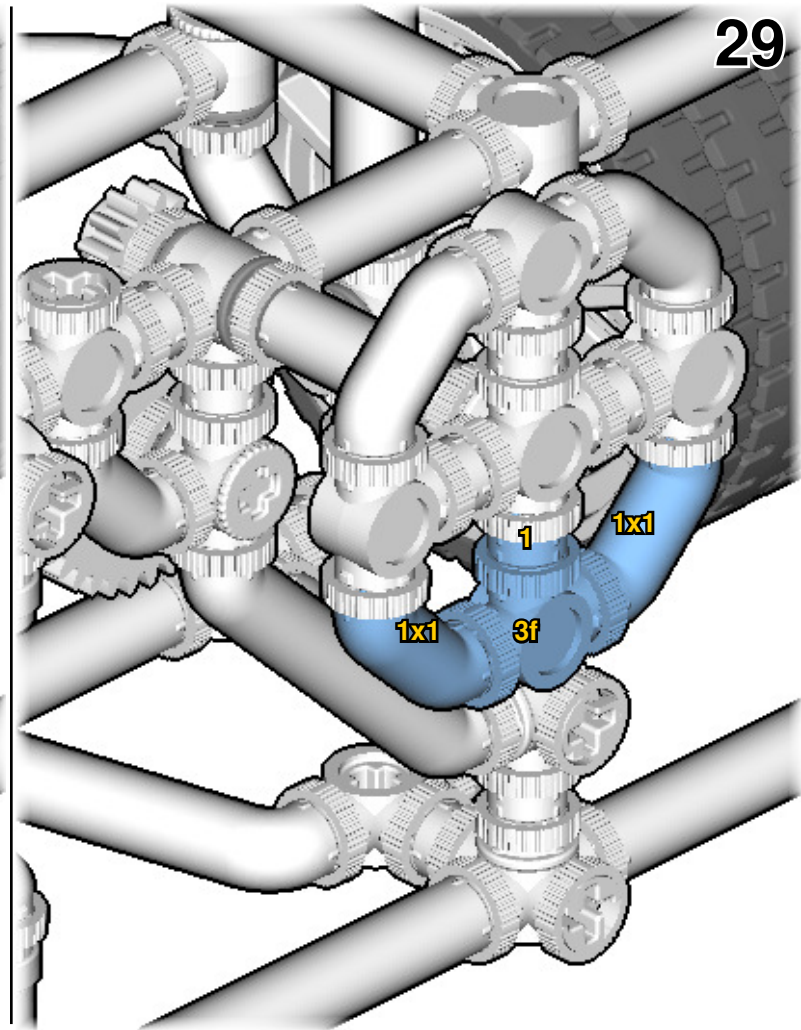
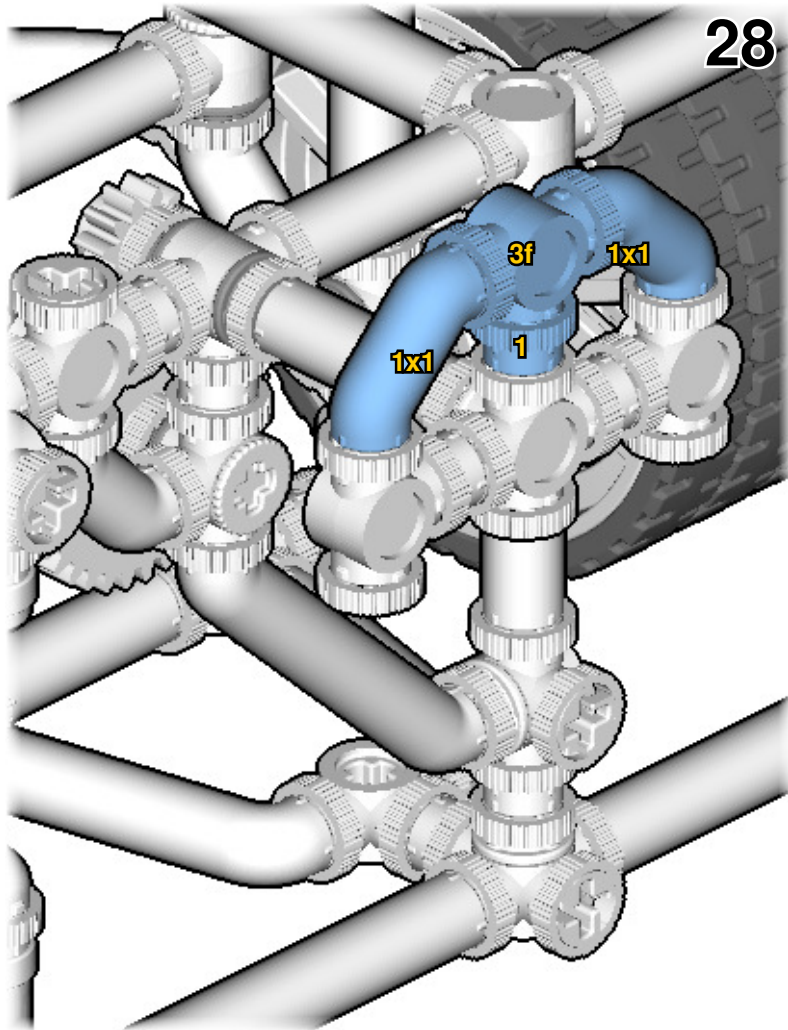

32

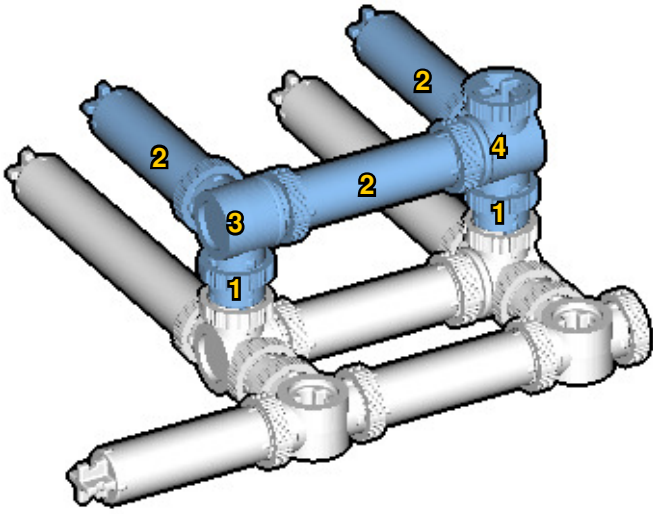

33

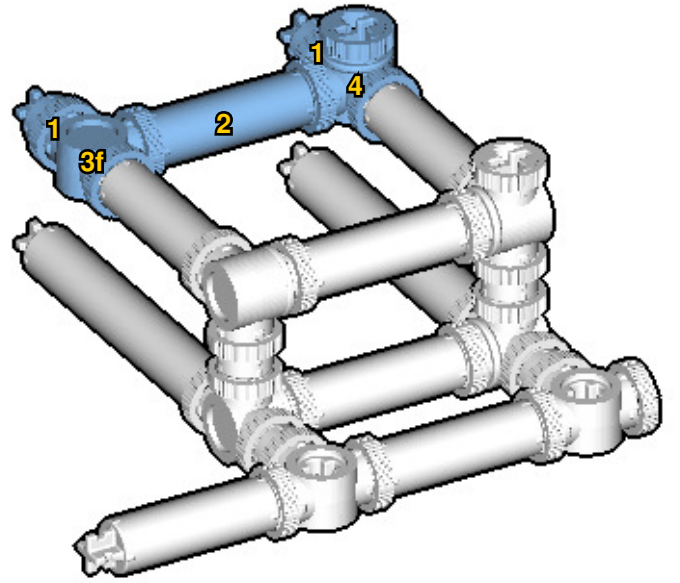

34

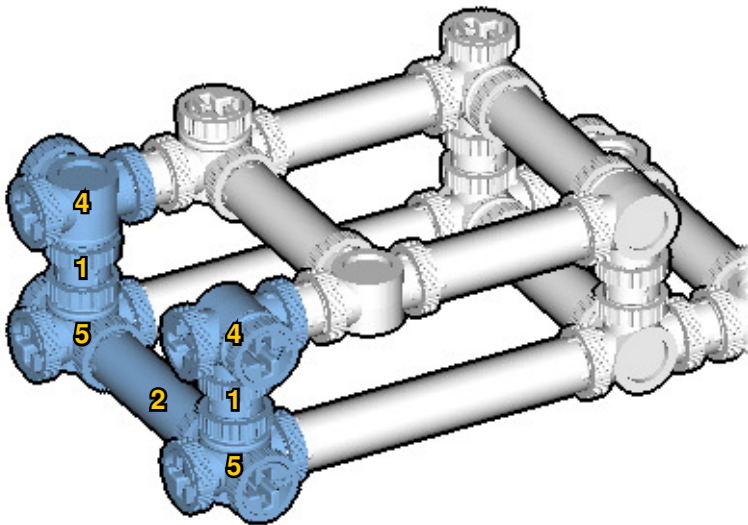

35

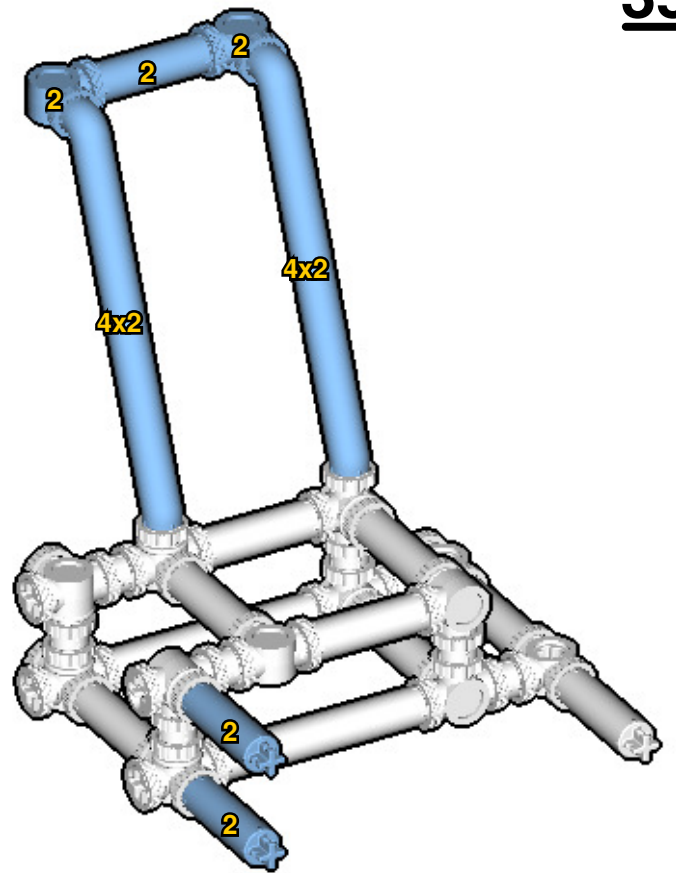

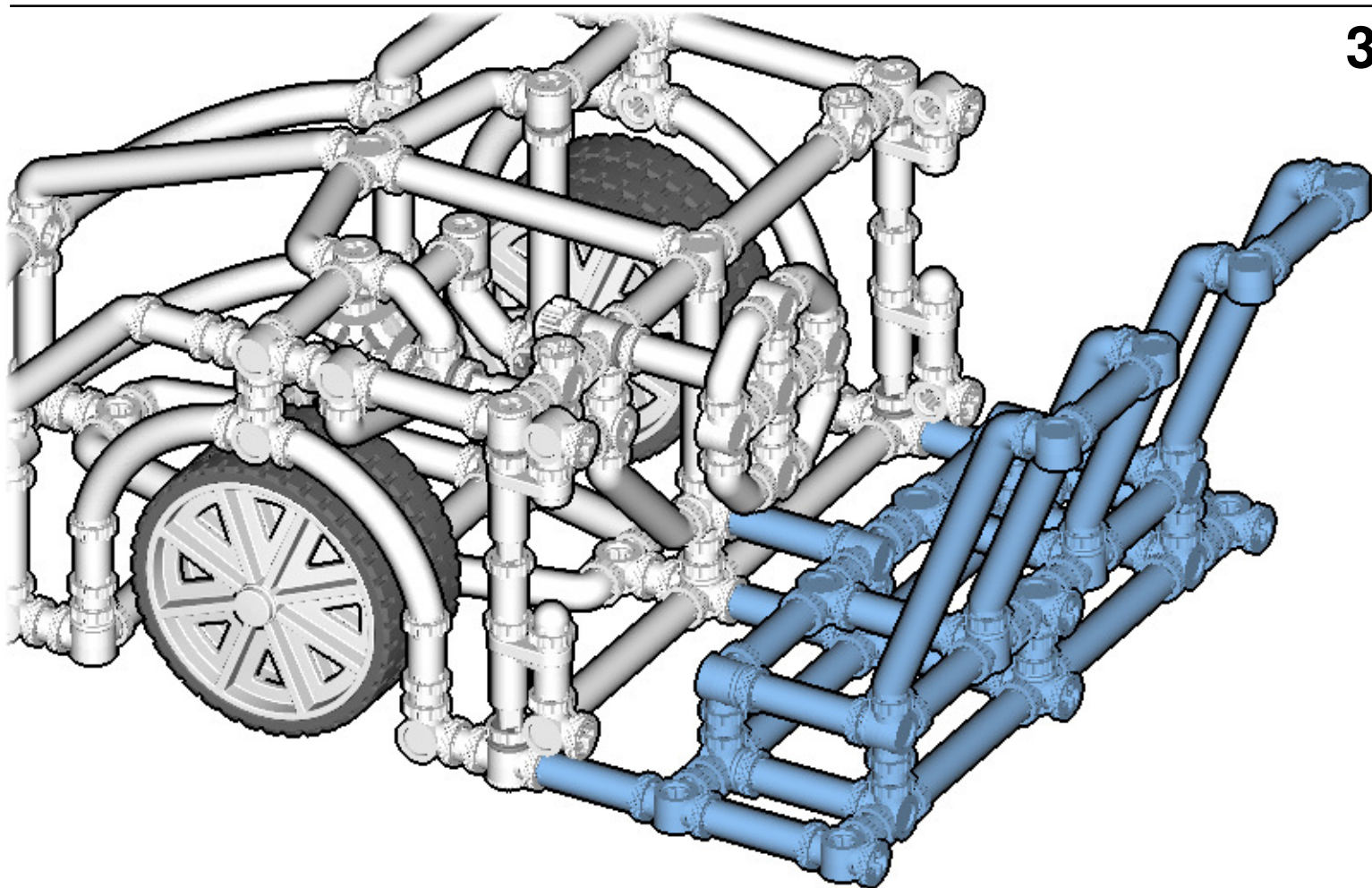
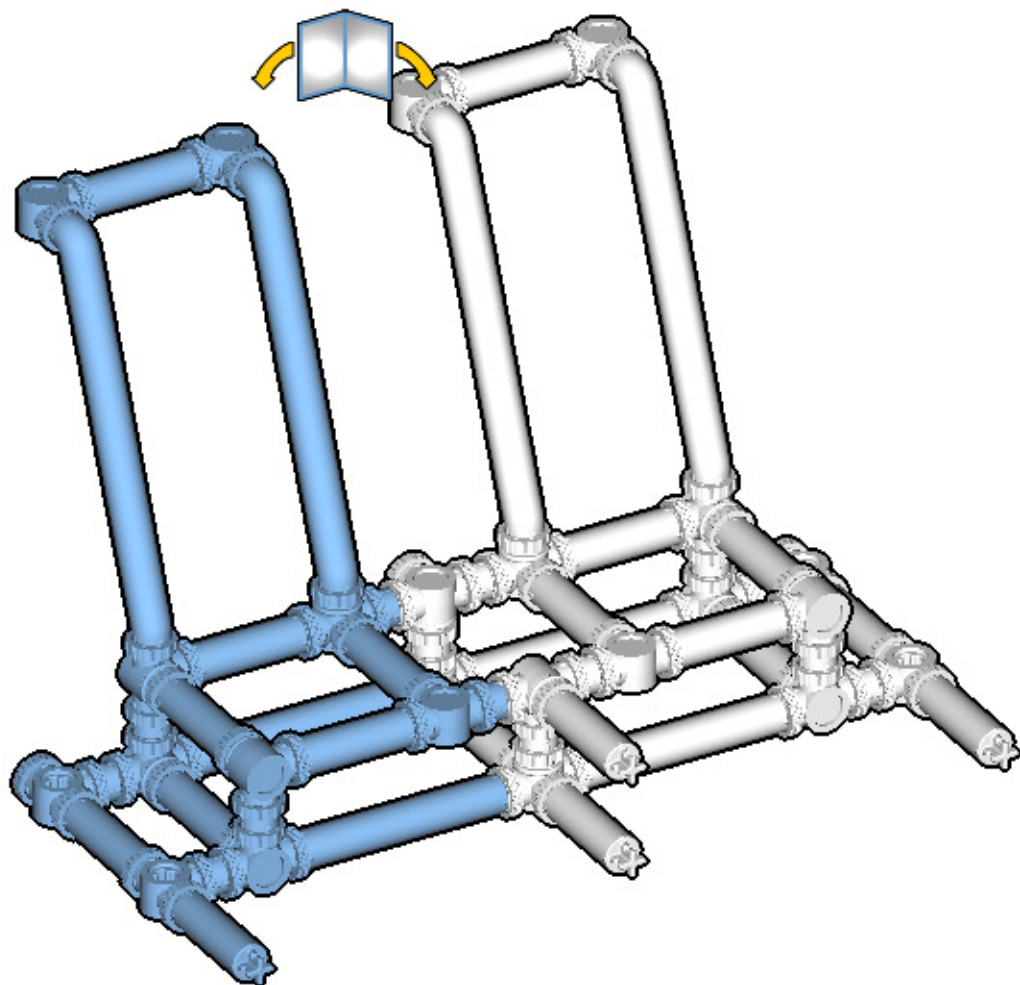

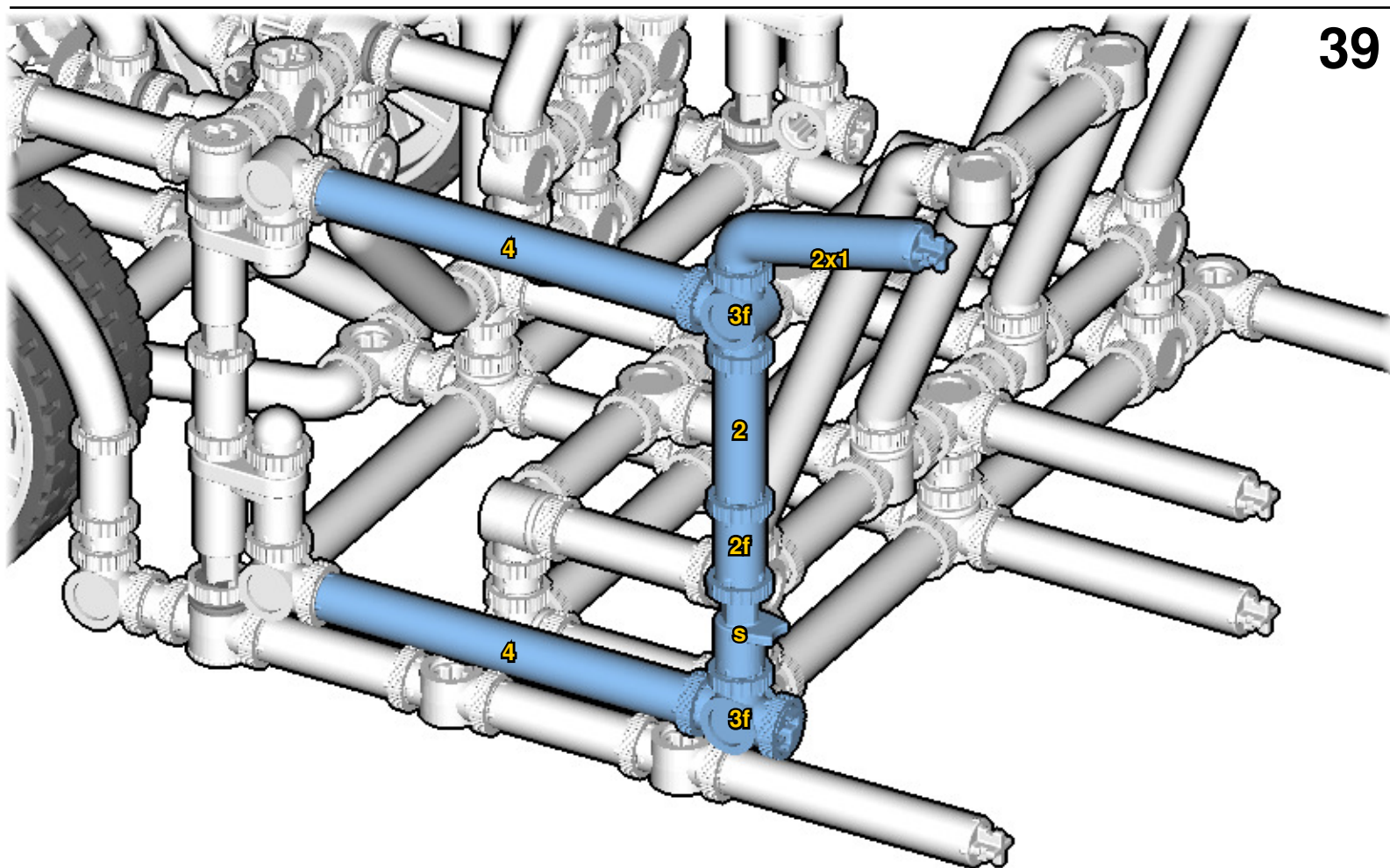
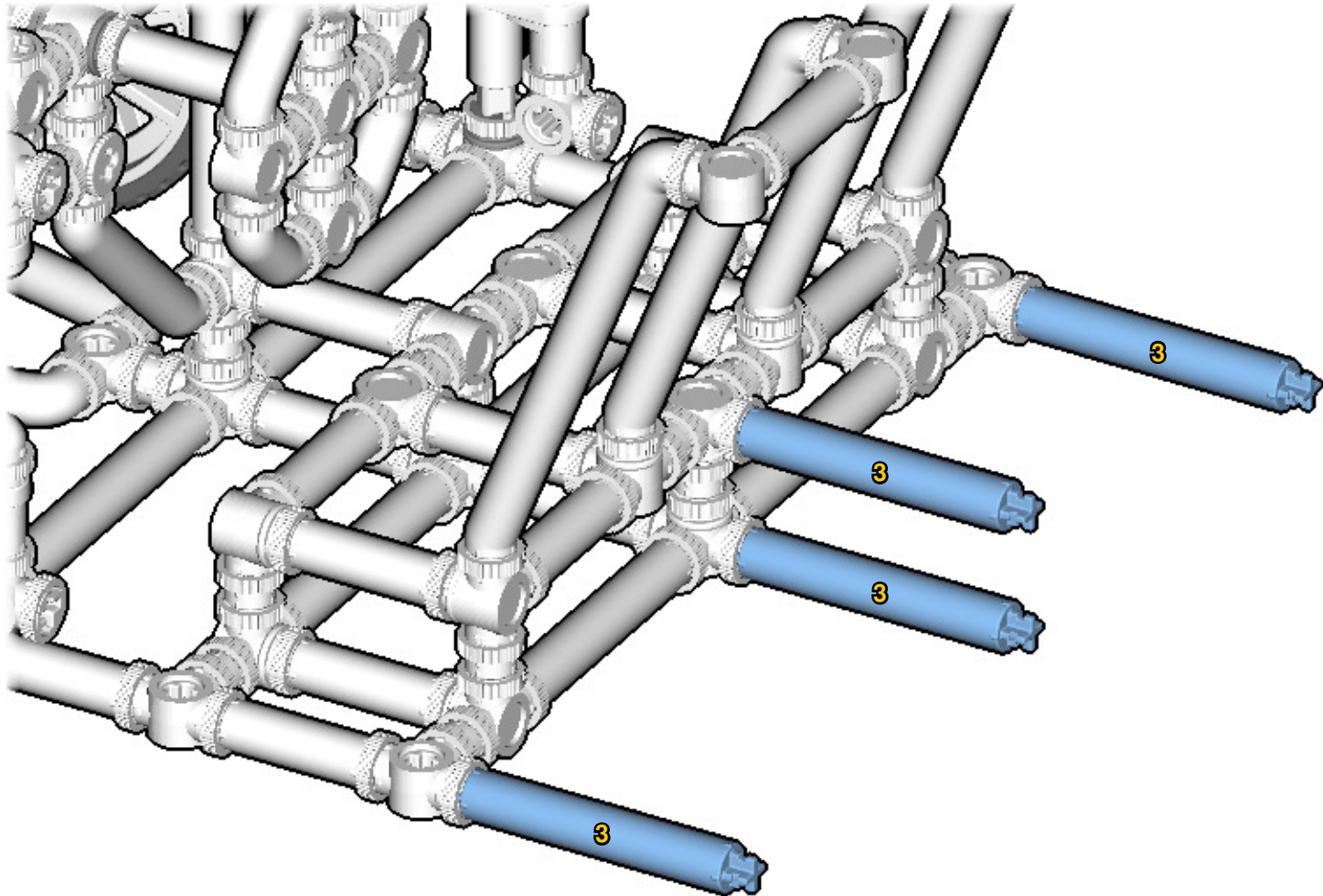

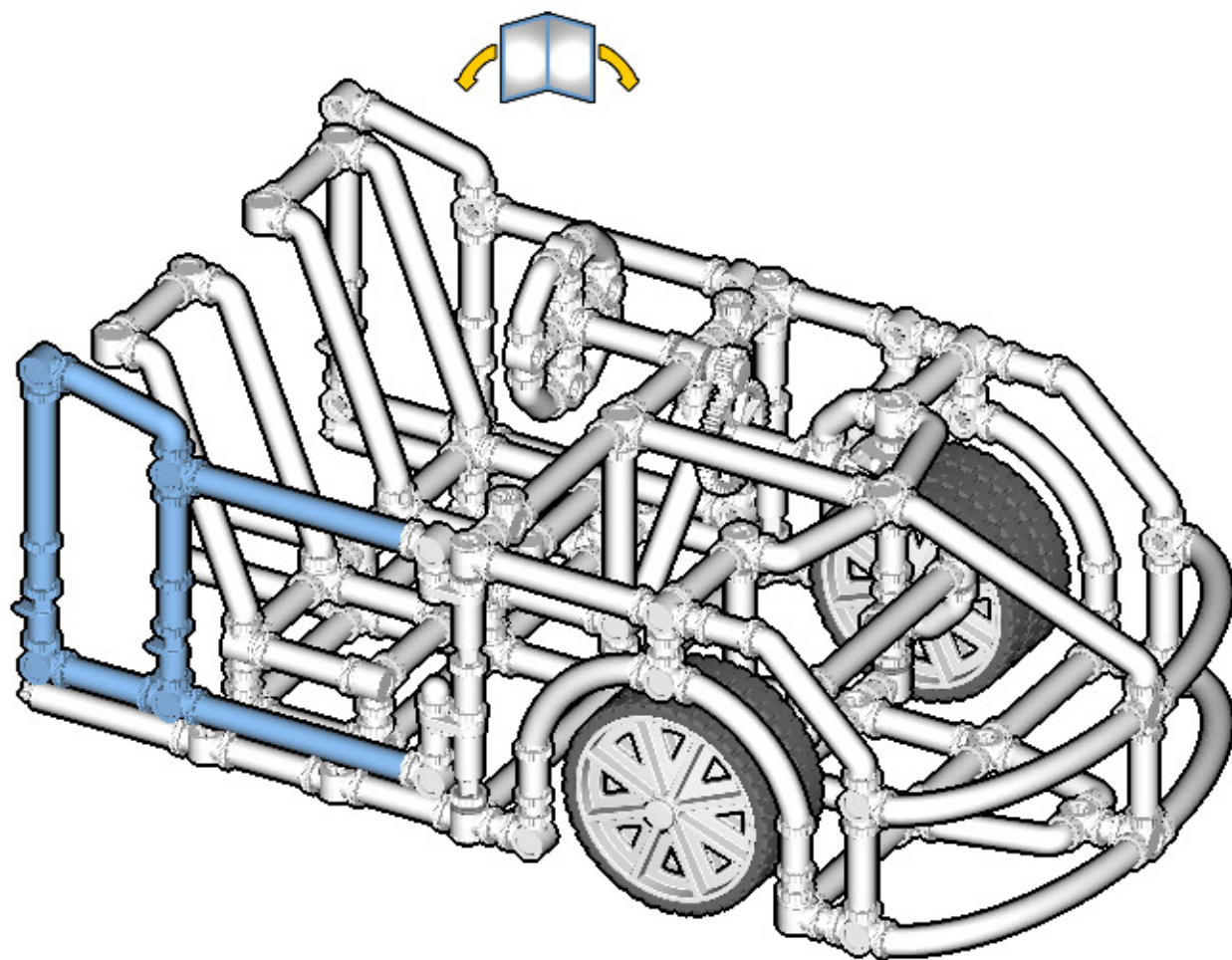
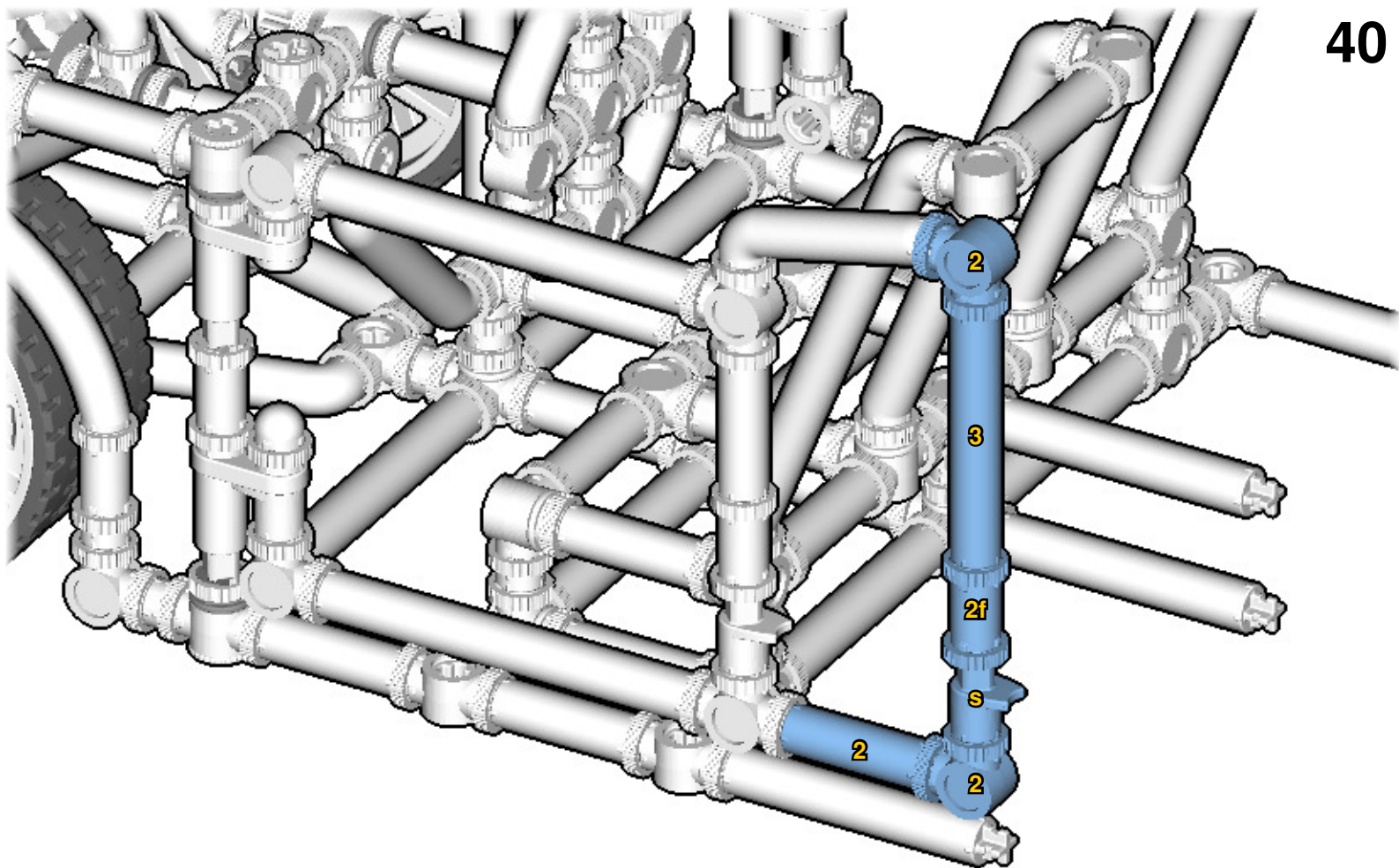

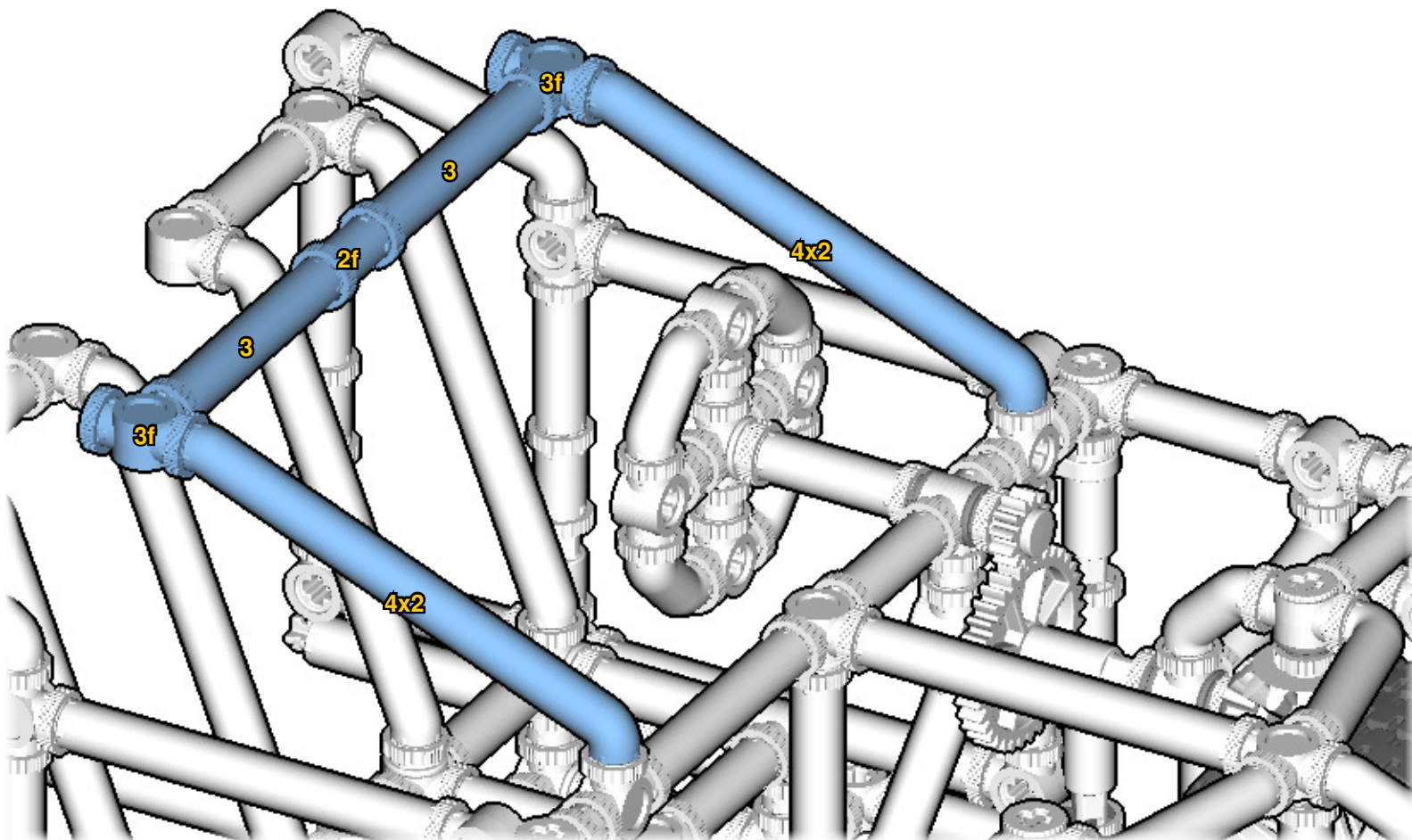
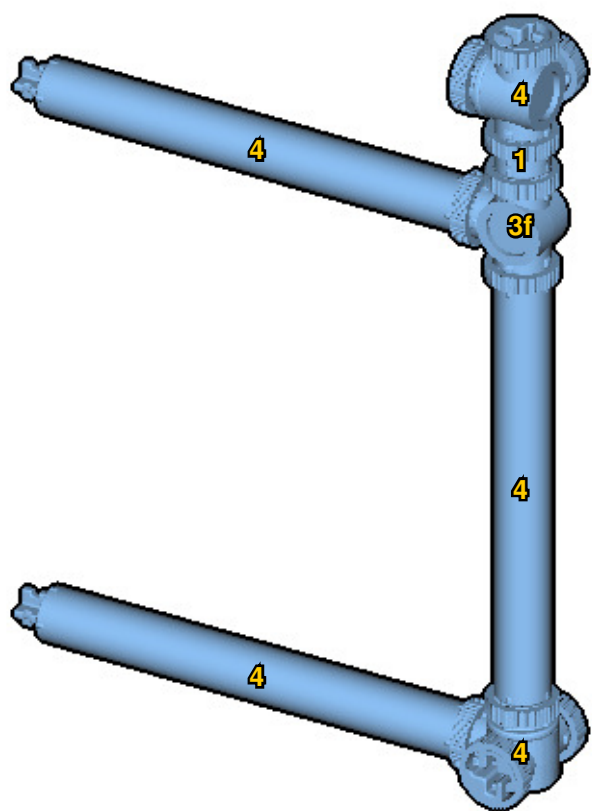
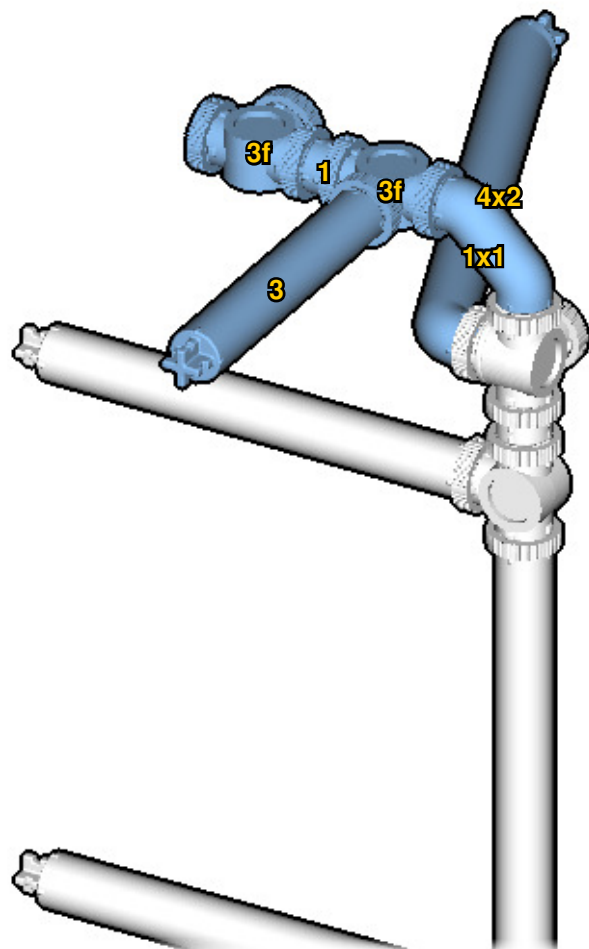
4344

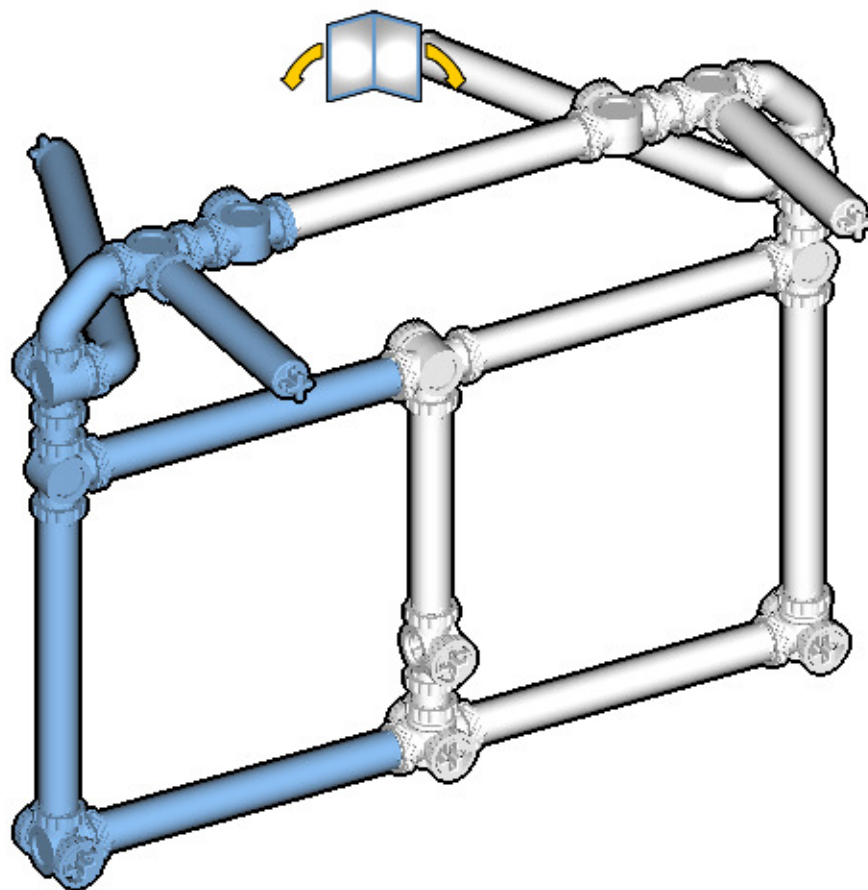
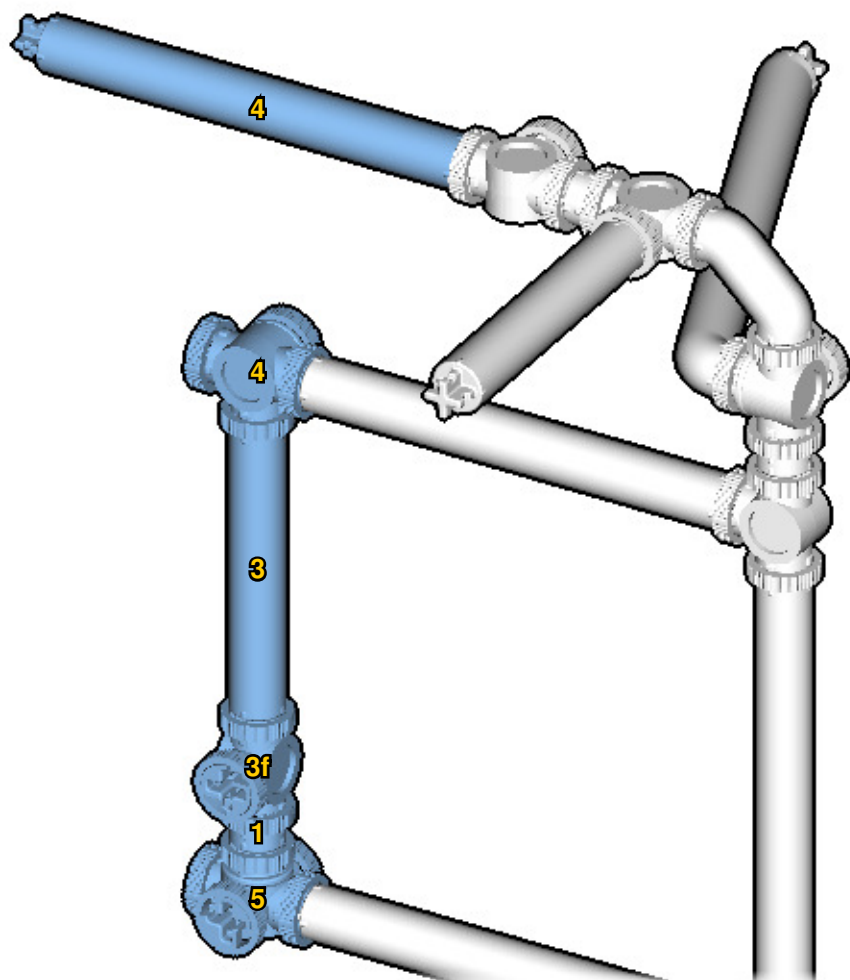

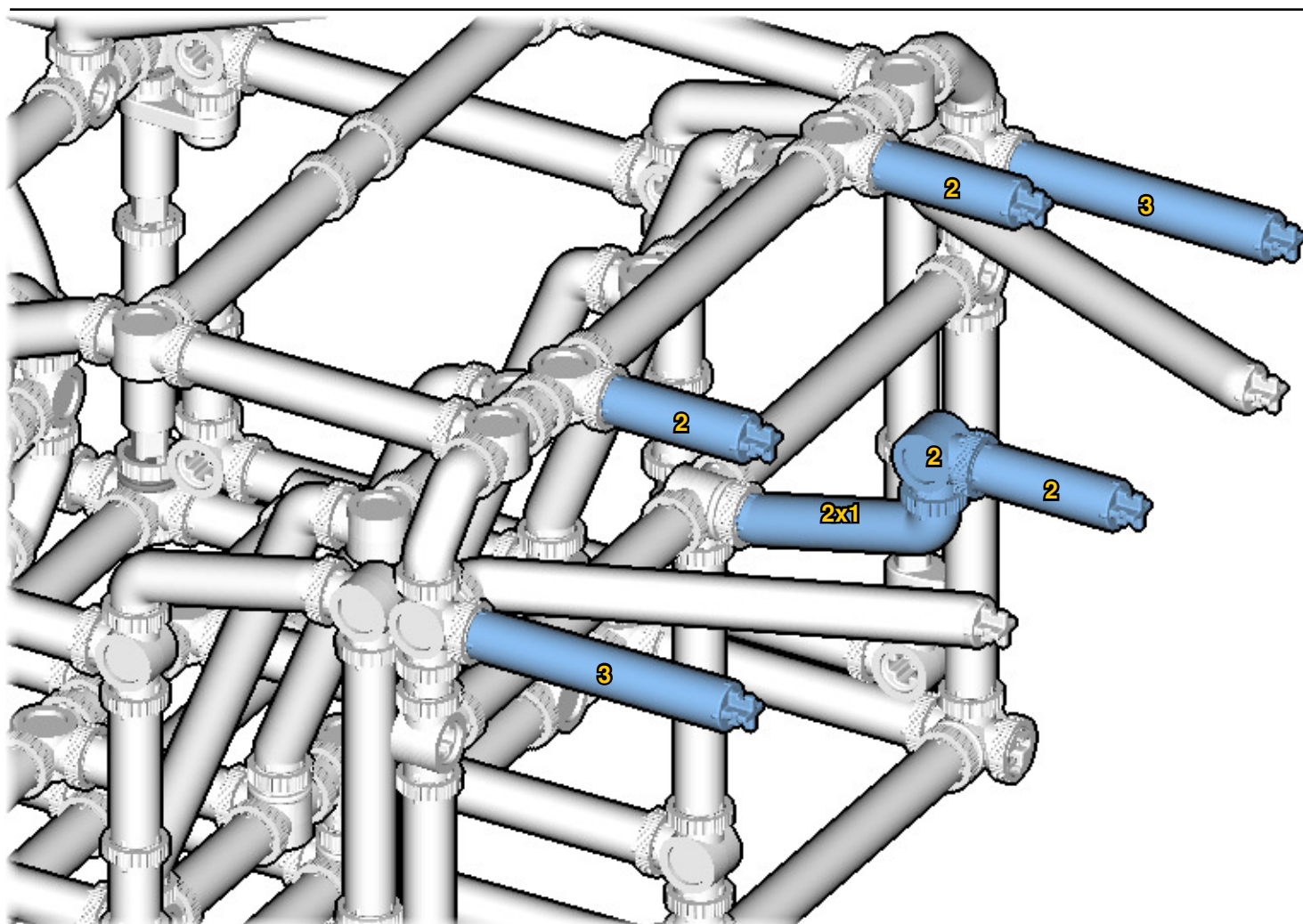
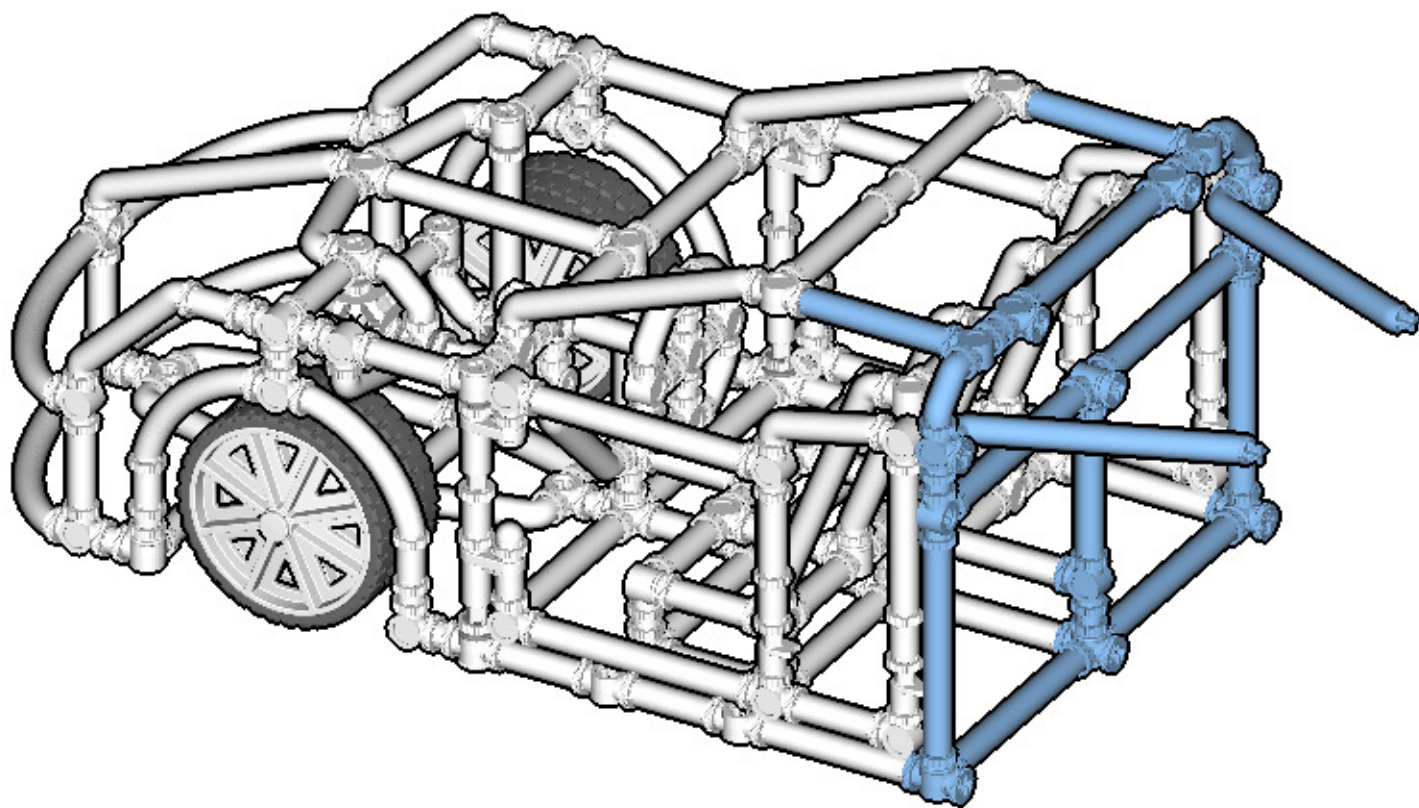

49

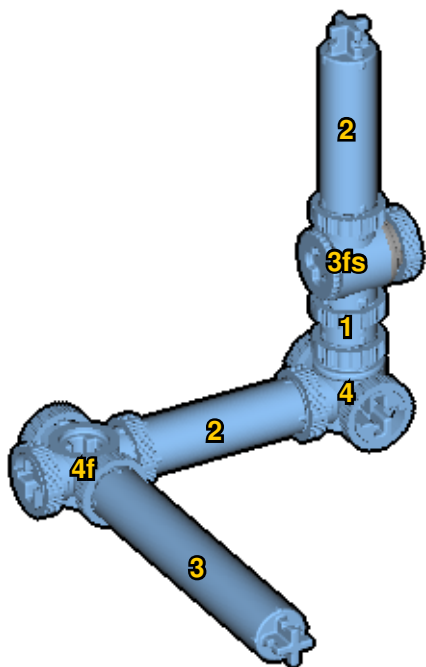

50

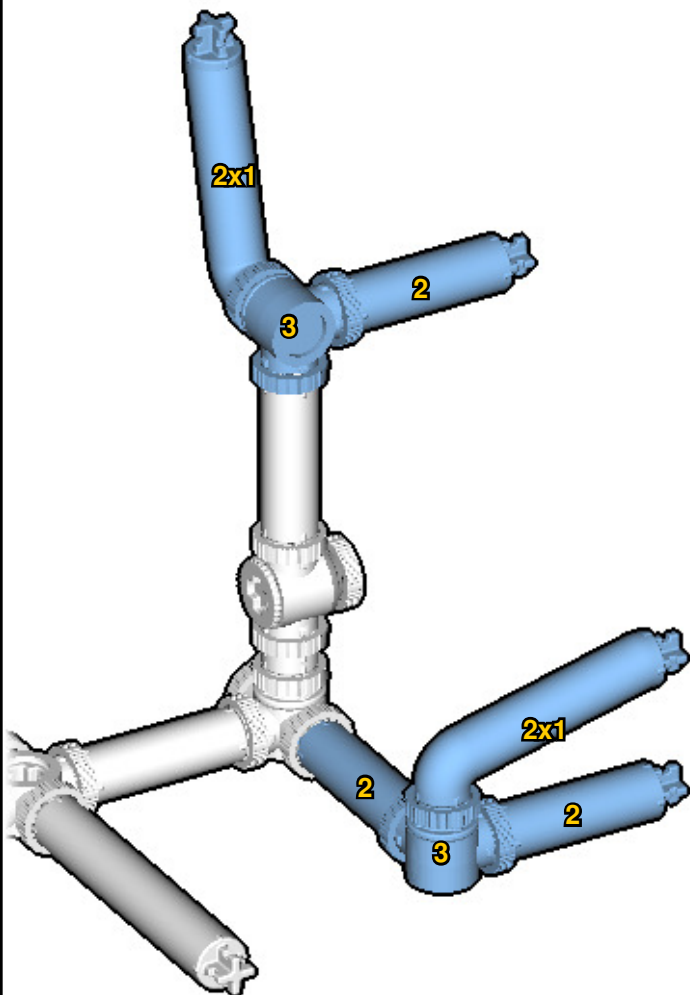

51

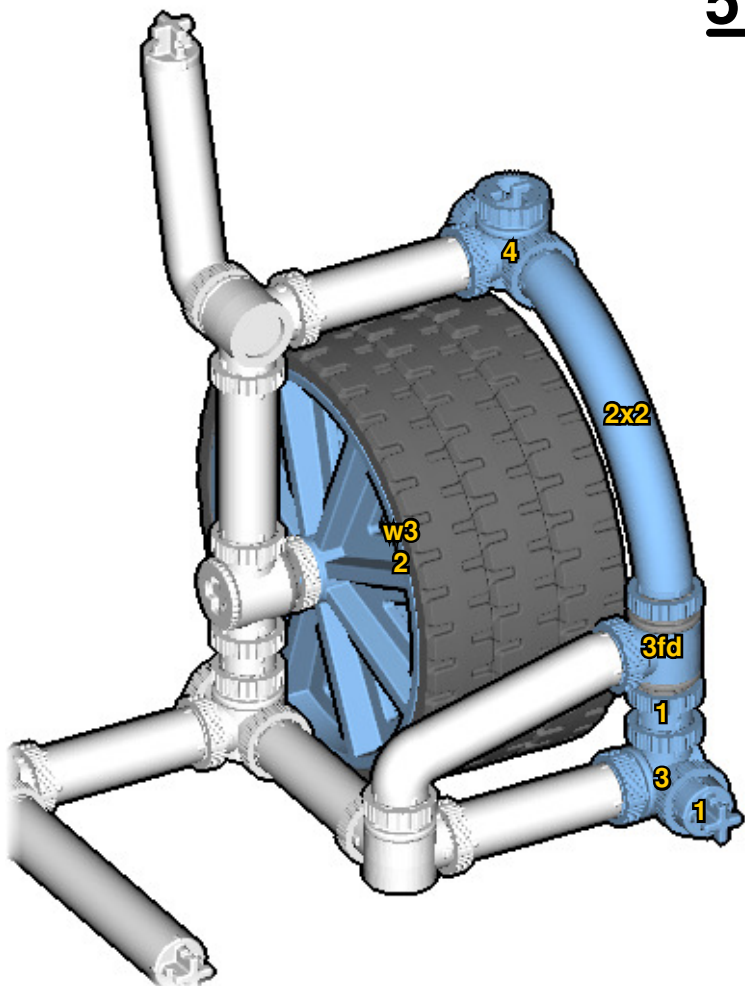

52

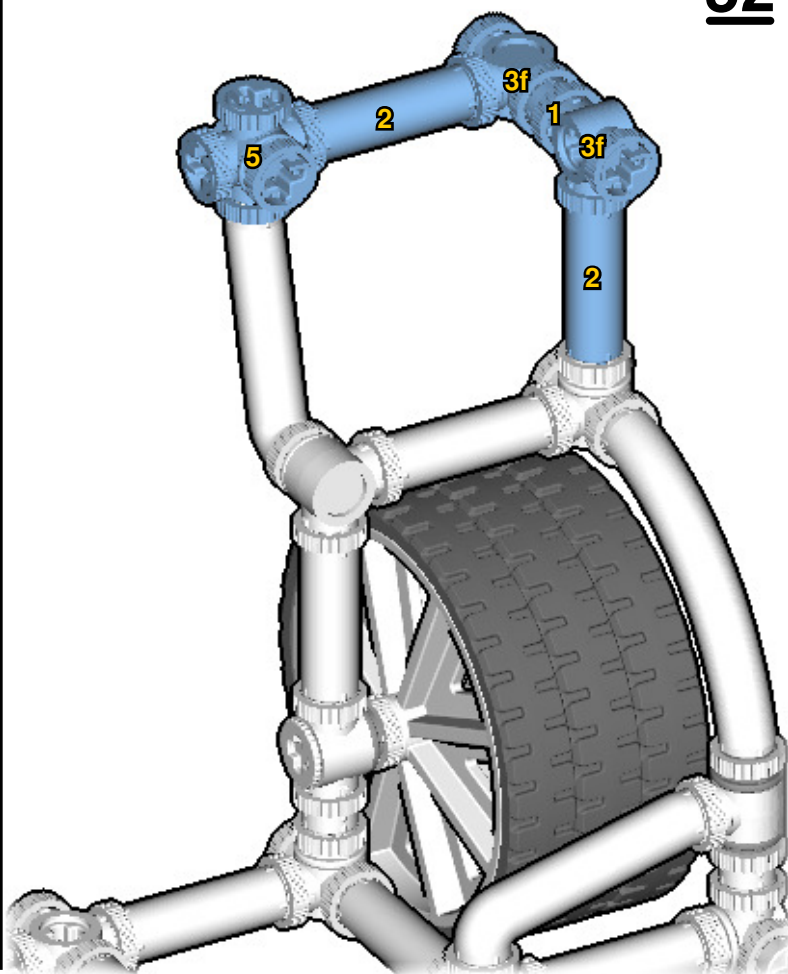

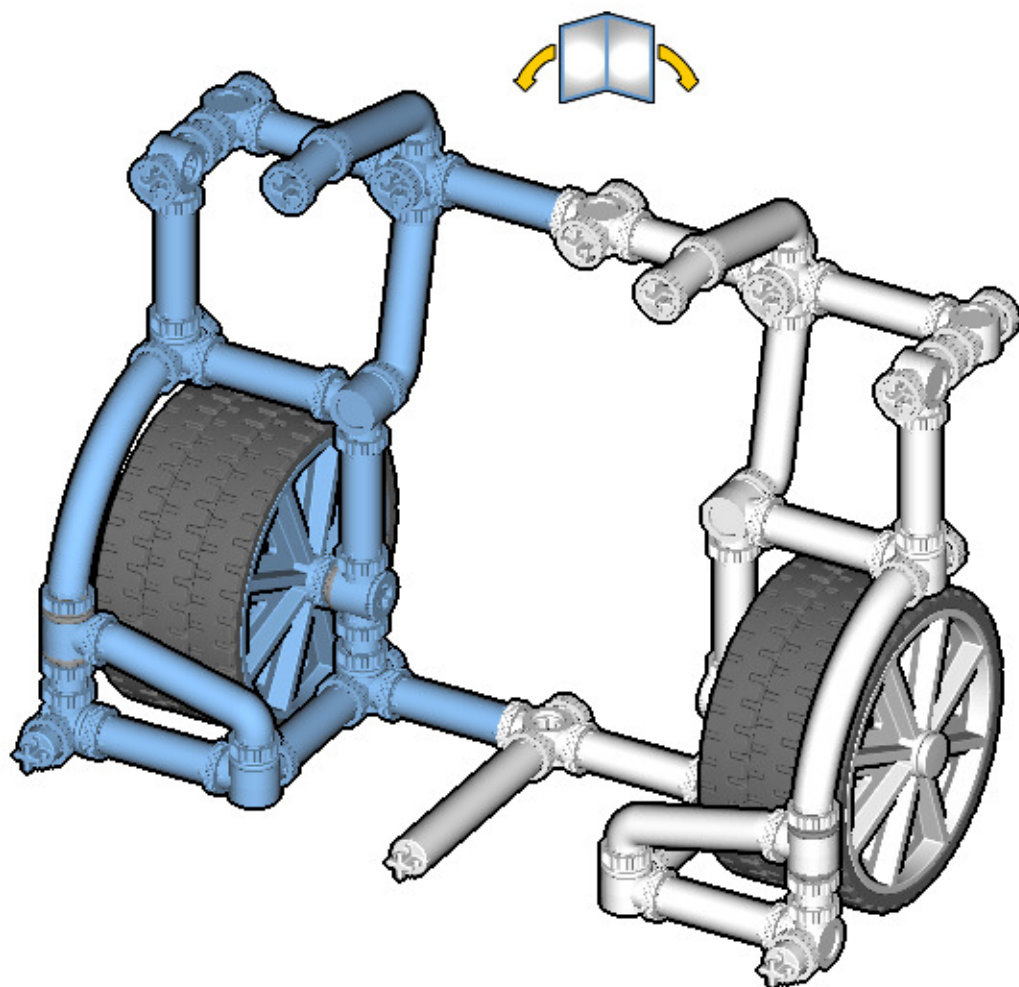
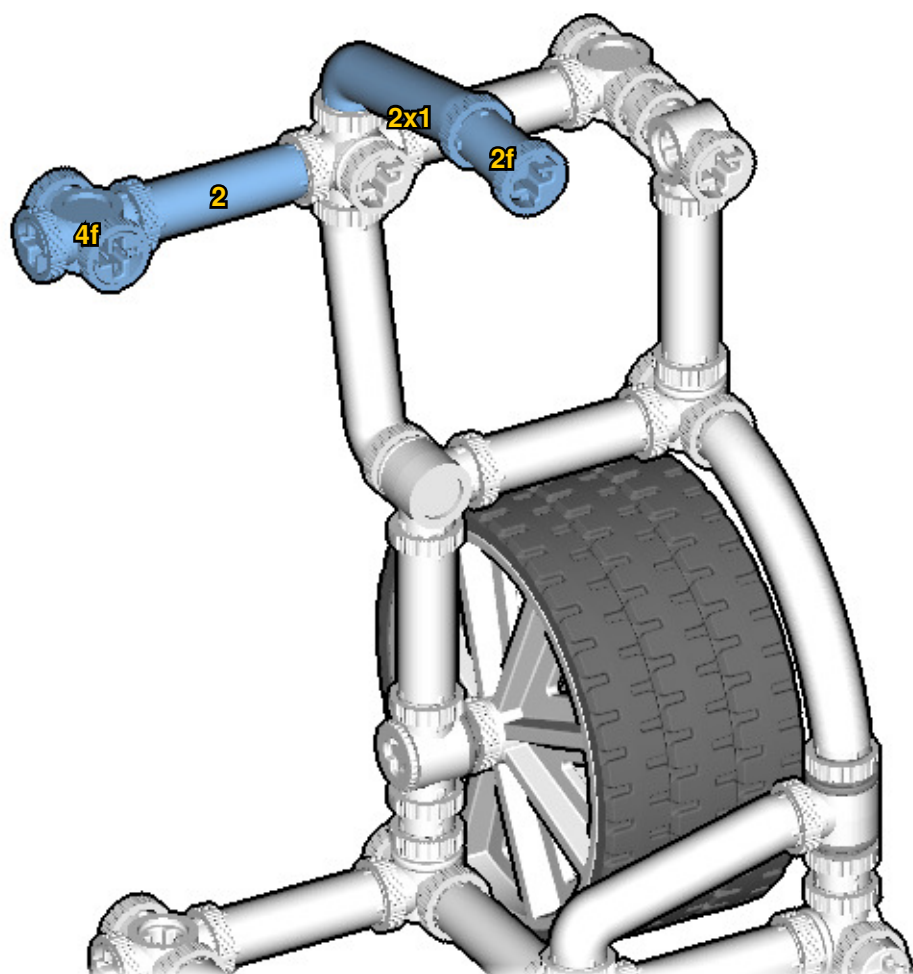

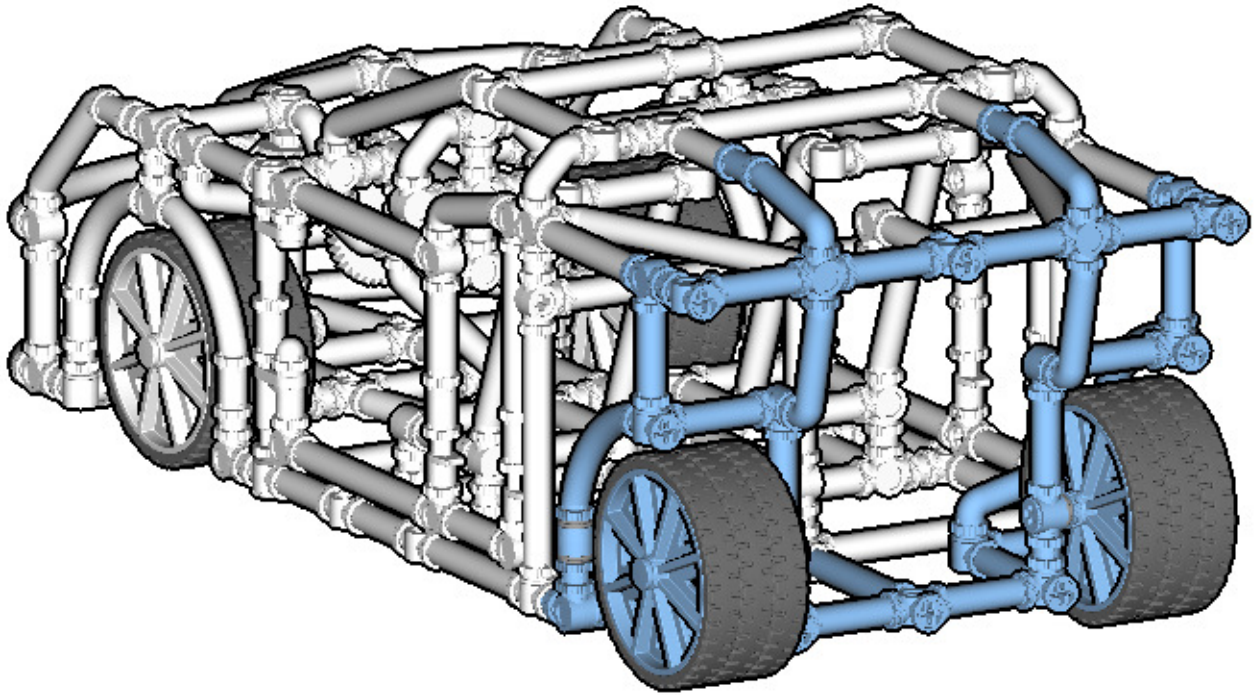

56

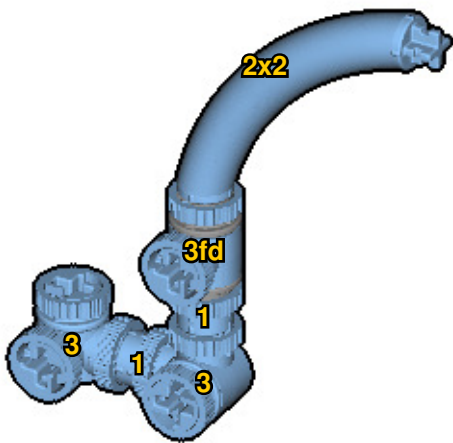

57

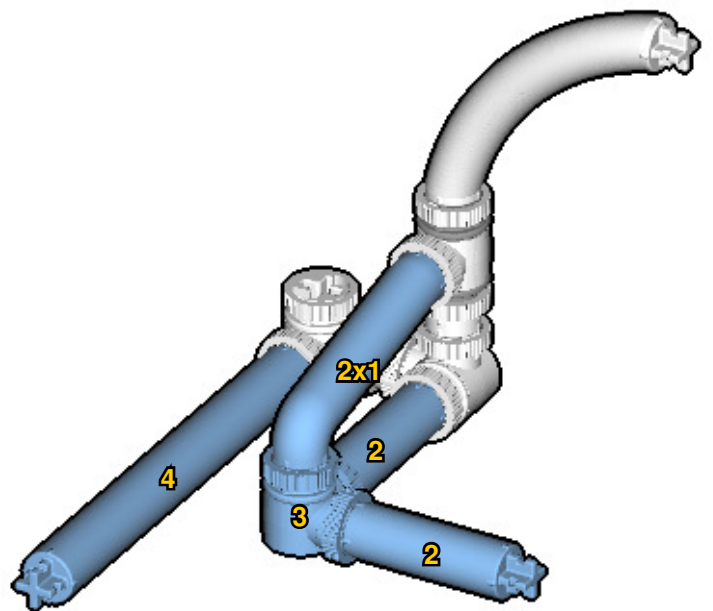

58

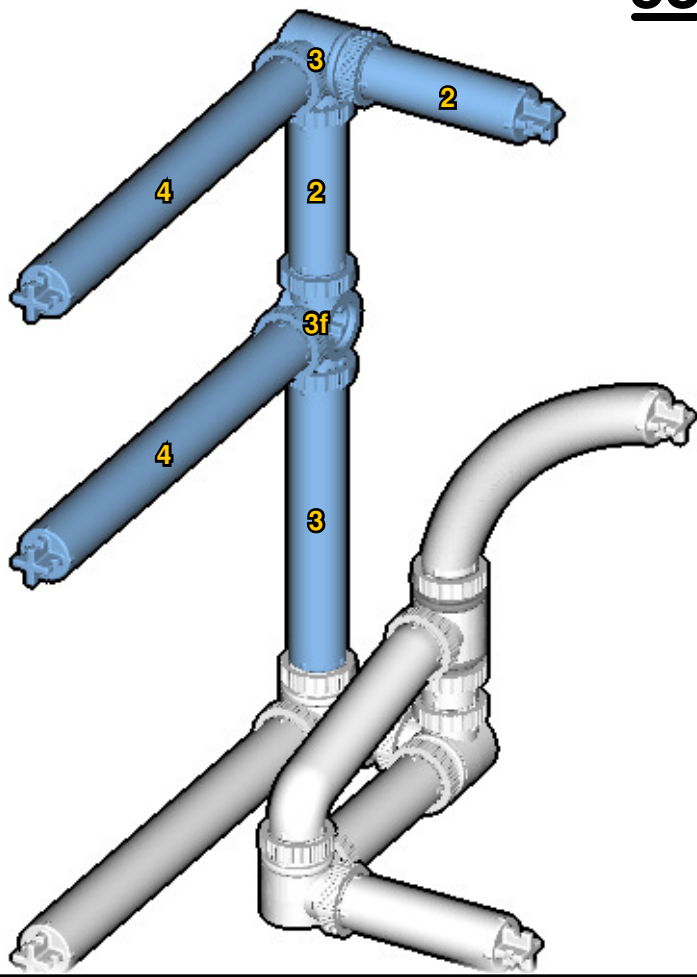

59

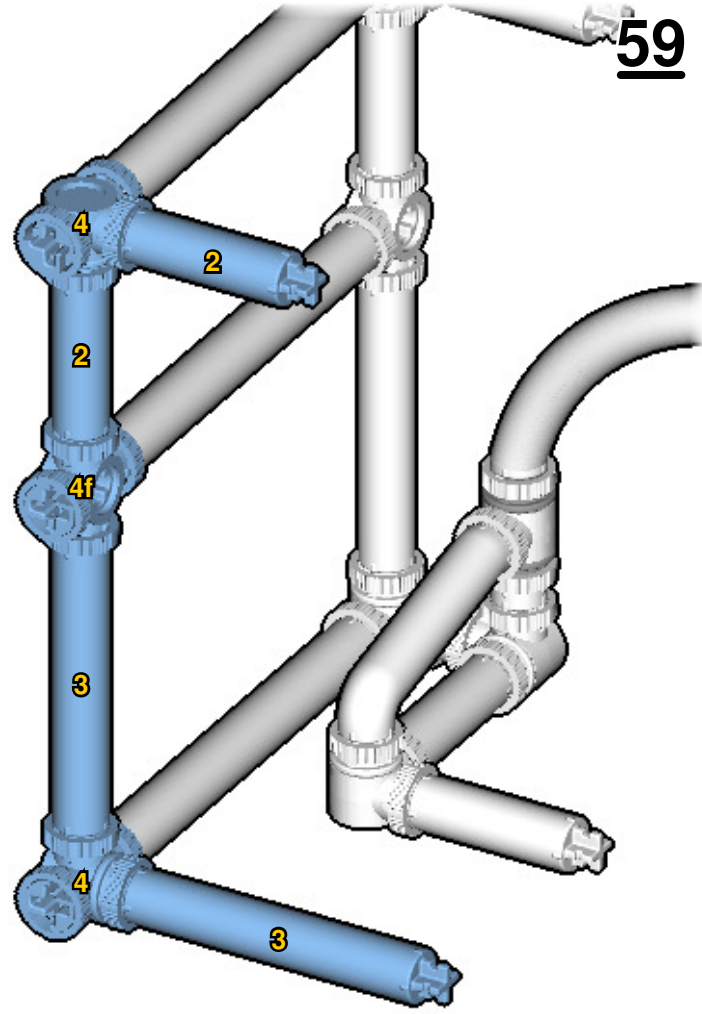

60

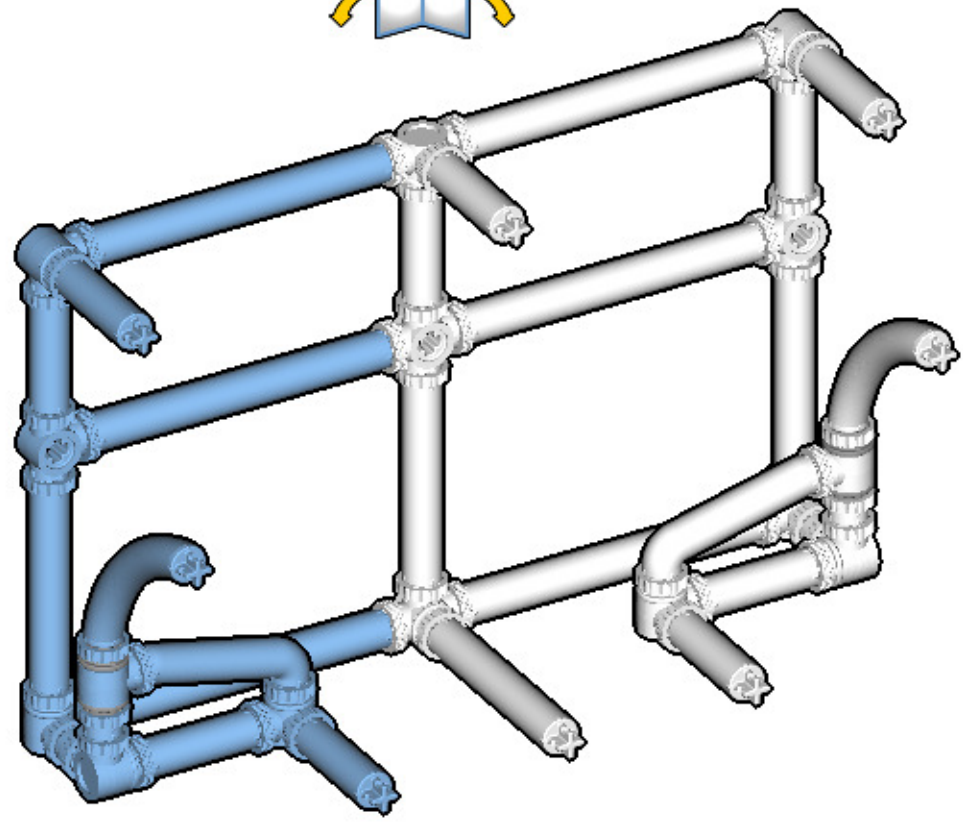
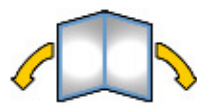

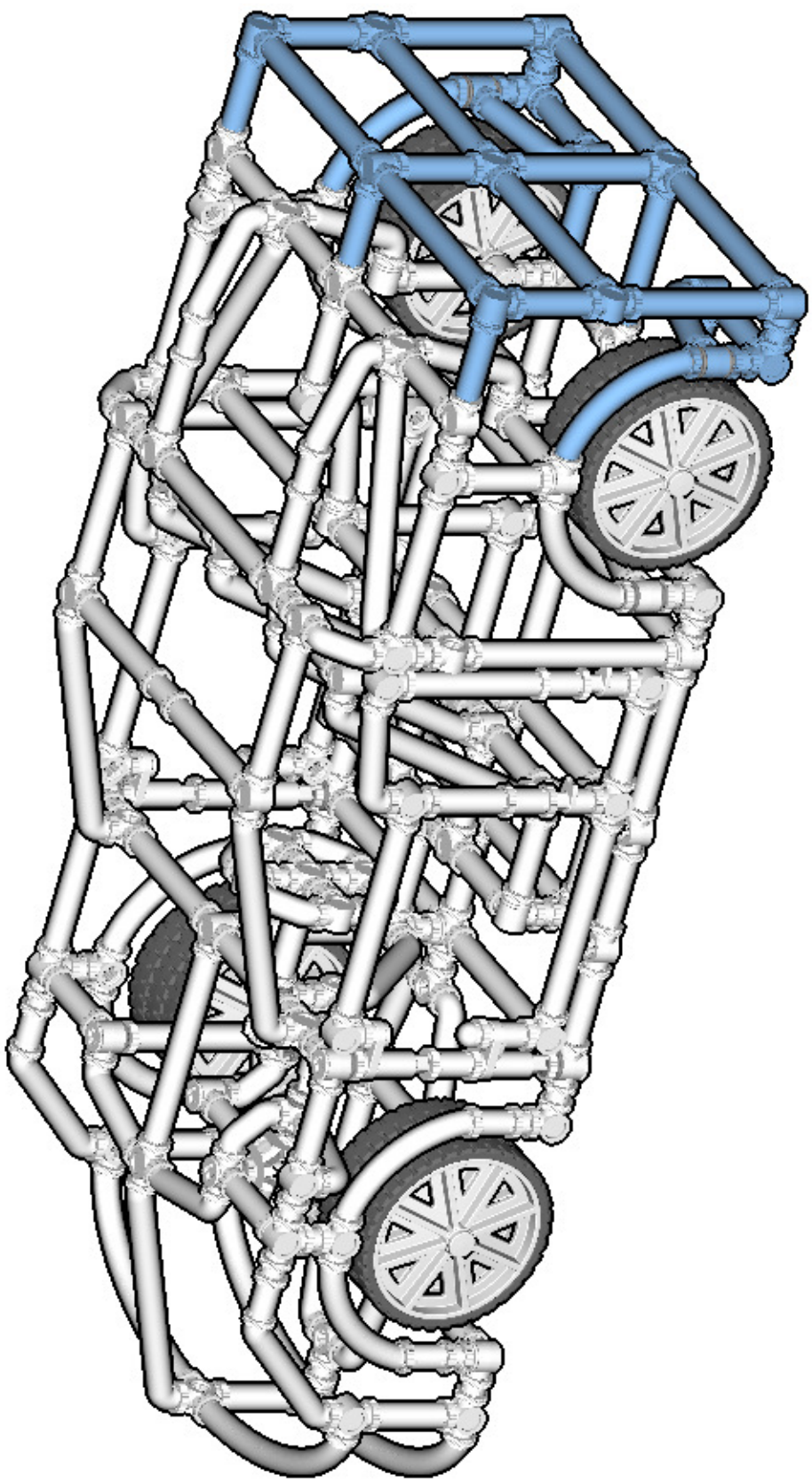

INVENTORY

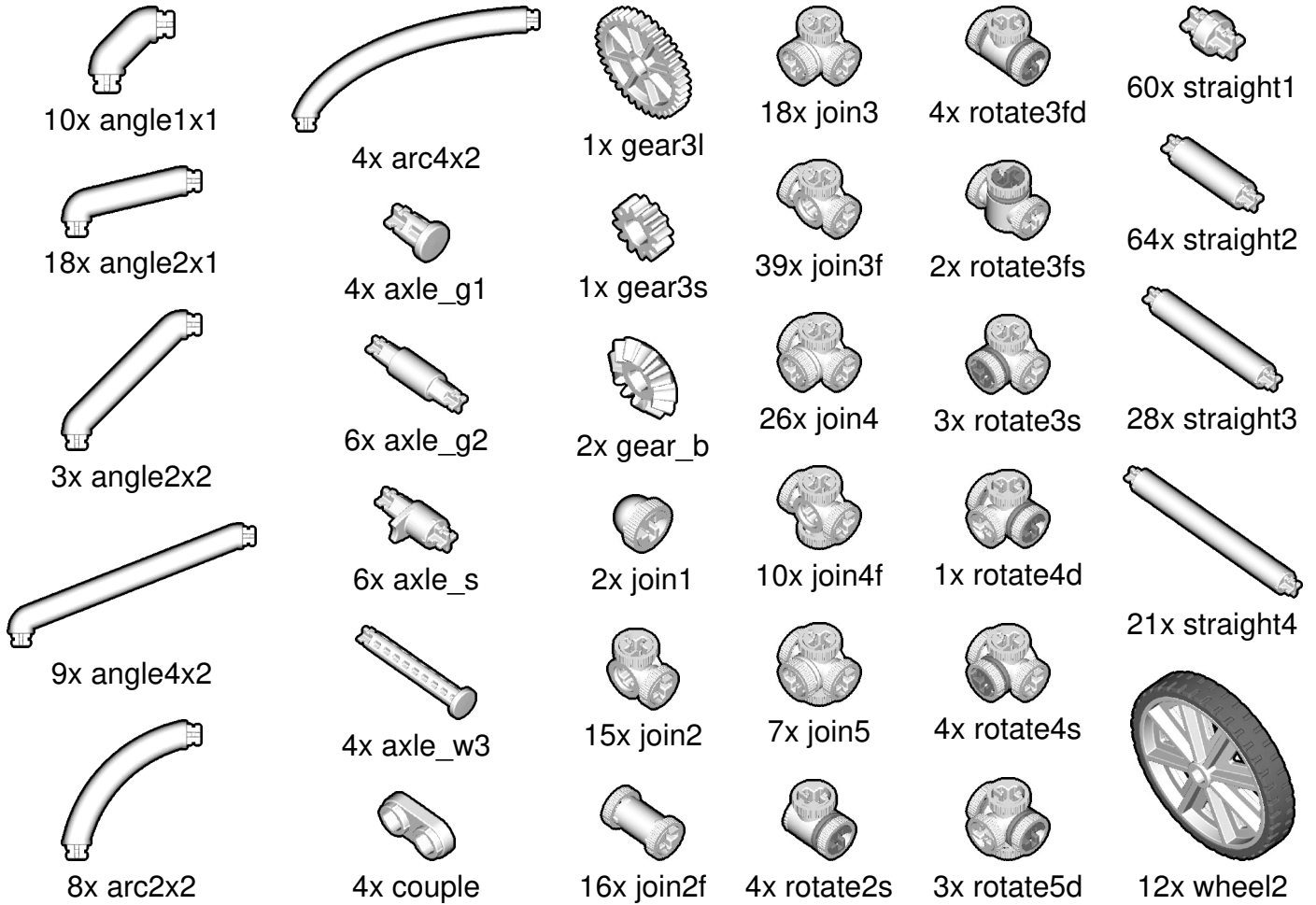

ACTUAL SIZE

